



# Sustainable Supply Chain Strategy and Sustainable Competitive Advantage: A Mediated and Moderated Model

Jianmin Sun<sup>1</sup>, Muddassar Sarfraz<sup>2\*</sup>, Kausar Fiaz Khawaja<sup>3</sup> and Muhammad Ibrahim Abdullah<sup>4</sup>

<sup>1</sup> School of Management, Nanjing University of Posts and Telecommunications, Nanjing, China, <sup>2</sup> School of Management, Zhejiang Shuren University, Hangzhou, China, <sup>3</sup> Faculty of Management Sciences, International Islamic University, Islamabad, Pakistan, <sup>4</sup> Department of Management Sciences, COMSATS University Islamabad, Lahore, Pakistan

## OPEN ACCESS

### Edited by:

Abdul Rauf,  
Nanjing University of Information  
Science and Technology, China

### Reviewed by:

Umair Saeed Bhutta,  
University of Technology and Applied  
Sciences, Oman  
Hamad Bin Azam Hashmi,  
Open University of the  
Netherlands, Netherlands

### \*Correspondence:

Muddassar Sarfraz  
muddassar.sarfraz@gmail.com

### Specialty section:

This article was submitted to  
Environmental Health and Exposome,  
a section of the journal  
Frontiers in Public Health

Received: 13 March 2022

Accepted: 19 April 2022

Published: 19 May 2022

### Citation:

Sun J, Sarfraz M, Khawaja KF and  
Abdullah MI (2022) Sustainable  
Supply Chain Strategy and  
Sustainable Competitive Advantage: A  
Mediated and Moderated Model.  
Front. Public Health 10:895482.  
doi: 10.3389/fpubh.2022.895482

In the global business environment, sustainability has become a competitive priority of most enterprises. Sustainability as a differentiation approach enables organizations to compete in today's environment. However, despite the increasing adaptability to sustainability practices, pharmaceutical supply chain management is still facing challenges in preserving the global environment. The study contemplates the impact of sustainable supply chain strategy and sustainable competitive advantage while considering the mediating role of sustainable supply chain practice and moderating role of sustainability inhibitors. The data was collected from the 180 employees working in the pharmaceutical companies of Pakistan. The study applied a quantitative approach for testing a theoretical model, using discriminant validity analysis, assessment of measurement model, composite reliability & validity analysis to assess the dimensions and model's reliability and validity. The study results show a positive relationship between sustainable supply chain strategy and sustainable competitive advantage. Sustainable supply chain practice mediates the relationship between sustainable supply chain strategy and sustainable competitive advantage, while sustainability inhibitors strengthen the relationship between sustainable supply chain strategy and sustainable supply chain practice. This study will help managers develop impactful sustainable supply chain management practices that will lead to sustainable performance.

**Keywords:** sustainable supply chain, strategy, sustainability inhibitors, sustainable supply chain practice, sustainable competitive advantage

## INTRODUCTION

Significantly, in recent years, the issue of sustainable development has become a fast-growing phenomenon, gaining the interest of global businesses and communities. As a result, today, the accelerating market competition and progressing globalization have drastically altered the supply chain demand, leading the government and stakeholders to encourage the integration of sustainable practices. Substantially, this developing concept led organizations to design business strategies (i.e., social, economic, and ecological), thereby focusing on supply chain sustainability (1).

Indeed, today's market instability has profoundly called organizations for sustainable development. This current scenario has encouraged most companies to embrace sustainable supply chain strategies (SSCS) for achieving their business targets. In explaining this notion, the research shows that, in supply chain management, designing a sustainable business strategy helps the organization achieve its business objectives (2). Accordingly, a sustainable supply chain framework indicates that firms' strategies help them achieve sustainable goals and management support (3). Perhaps, understanding the significance of growing sustainability inspires the management to focus on developing sustainable strategy designs (4). Hence, this sustainability idea demands organizations to integrate sustainable supply chain strategies across the organizational levels. SSC makes the organizations serve different sustainability dimensions (i.e., social, economic, environmental), thereby making the firm hold an invincible market position (5). Therefore, in studying the impact of sustainable strategy, it has become imperative to recognize its link with a sustainable competitive advantage.

Additionally, in the strategic alignment to SSCS, the sustainability concept allows the firms to achieve a distinct advantage, matching the firms' business goals. The sustainable competitive advantage (SCA) fosters the companies' performance, thereby making organizations outperform their peers. Given the articulation, the study shows that the enduring competitive advantage improves firms' performance, financial outcomes, and employees' commitment (6). Furthermore, the company's strategic tool (i.e., SCA) also encourages achieving the triple sustainability dimension (i.e., economic, social, ecological). Given the statement, the study shows that companies embracing supply chain strategies achieve a superior advantage in the hyper-dynamic business environment (7). Altogether, this concept of balanced sustainability increasing adds to the firms' value, thus ensuring long-term advancement and competitiveness (8).

However, besides the growing sustainability advantage, the medical industry is still encountering challenges regarding supply chain stability. The pharmaceutical division is the most lightened industrial sector that demands sustainability in serving humanity. The pharmaceutical bestowed the responsibility to deliver life-saving products to humanity. Given the articulation, the study shows that the industry's production (e.g., material, products, services) extensively influences societies' wellbeing (9). In particular, the medicine industry holds a prominent position among the global economies, highlighting the need for enduring strategies. In serving society, the literature shows that pharmaceutical companies are increasingly facing problems such as medical waste, thus requiring the need for sustainable strategies for securing the global environment and societies' (10). Perhaps, based on this statement, the prior study shows that the pharmaceutical sector concerning the supply chain remains underdeveloped (11).

In particular, sustainability, the foremost agenda, elevates the need for firms' sustainable practices. SSCS plays a critical role in promoting sustainable practices. It serves as the ground for developing SSCP, thus achieving organization goals (12). Moreover, SSCPs make the organization achieve a multi-dimensional sustainability purpose. Given the explanation, the

study states that sustainable practices ensure firms' enduring performance (e.g., eco-friendly practices, green products) (13). Similarly, the study also states that these positive sustainability dimensions improve the firms' practices (14), thereby achieving an enduring advantage.

Moreover, in ensuring enduring practices, numerous factors associated with firms' stability require consideration. However, without an adequate understanding of eco-friendly inhibitors, it is difficult for organizations to evaluate their sustainability practices. Sustainability inhibitors are naturally occurring substances that limit the corrosion of intoxicant materials. The intoxicant inhibitors are a barrier to achieving firms' sustainability. The usage of eco-friendly inhibitors ensures an improvement in the environment (15). These latest developments save humanity and the environment from harm. Given the illustration, the study shows that different eco-friendly alternatives (e.g., medicines, drugs, toxic-free chemicals) are extensively adopted to enhance the firms' sustainability practices (16). Hence, organic inhibitors are an essential alternative to improving firms' practices (17). Indeed, the literature depicts these sustainable inhibitors as the prime development of today's era.

However, in recent years, the initiative of sustainable development has massively captured the attention of most pioneer organizations. However, the literature indicates that it has become difficult for the pharmaceutical industry to sustain itself in today's competitive environment. In particular, the literature concludes that despite the increasing growth of SSC, its importance in the pharmaceutical industry still needs attention. Moreover, the above considerations demand investigation in the medical sector compared to other divisions. The literature states that sustainable supply chain practices are of high complexity in the supply chain (18), which colossally needs investigation.

Therefore, against this drawback, this study contributes to SSCM by determining the impact of organizational sustainability from a competitive advantage perspective. Significantly, this study fulfills the research gap by investigating the relationship between the sustainable supply chain strategy and sustainable competitive advantage. Similarly, it also analyzes the mediating role of sustainable supply chain practices and moderating role of sustainability inhibitors nexus the relationship between SSCS and SCA.

Fundamentally, this study is multidisciplinary research that encourages implementing the sustainability concept in gaining a competitive advantage. In particular, this paper extensively shifts the focus of several scholars to sustainable supply chain management. It is a significant study that incorporates the concepts of supply chain and sustainability, thereby elevating the need for achieving sustainable advantage. Moreover, it includes the dimensions of sustainability under the supply chain context, thereby making organizations understand the sustainability approaches to improving the competitive advantage. Indeed, this current understanding of SSC is of colossal importance to organizations. It encourages firms to align their business practices to the strategic plan of achieving long-term functionality. Moreover, this study seeks the best approaches to enhancing the

firms' sustainability by suggesting the governments, stakeholders, management, and organizations comply with environmentally friendly strategies to gain distinctive advantages.

The first section introduces the research topic by defining the research objectives and significance. Furthermore, the literature review (i.e., Section Hypothesis Development) presents the background of the study. In the same vein, Section Study Methodology describes the research tools and methods. After, the subsequent section documents the study findings, with Section Discussion discussing the outcomes in the light of empirical literature. Finally, the paper ends with the conclusion, research limitations, and future directions.

## HYPOTHESIS DEVELOPMENT

### Sustainable Supply Chain Strategy and Sustainable Competitive Advantage

Over the years, the increasing globalization has massively emphasized the adoption of sustainable supply chain strategies, fundamentally opening new avenues in the era of increased competitiveness. However, understanding this source of sustainable competitiveness has led organizations to embrace novel strategies for accelerating firms' advancement. The sustainable supply chain strategy is a robust strategical plan that helps firms defeat the market rivalry, thus gaining a sustainable competitive edge. Given the illustration, the study states that the sustainability approach develops value across the production chain, potentially discovering new sources for distinctive advantages (19). Accordingly, the study appreciating SSCS as a sustainable benefit states that in the supply chain network, the sustainable strategies enable the organizations to foster competitiveness, thus acquiring sustainable competitive advantage (20).

In particular, the effective SSCS enables the firms to harmonize their business activities, thereby strategically intensifying their business position. Given the illustration, the research reveals that the sustainability triple-bottom-line dimensions (e.g., social, economic, and ecological) make SSCS accomplish a dominant position in the marketplace (5). As a result, today, sustainability strategies have become critical to function internally, thereby accomplishing the organization's sustainable goal (21). The key to gaining sustainability is to sustain in the increasingly competitive environment, substantially obtaining long-term competitive stability. In the supply chain business environment, the SSCS facilitates a business operation, proactively regulating market changes. Based on this statement, the study shows that the SSCS provides competitive benefits to the firms', thus making them operate in a dynamic business environment (22). Significantly, the SSCS provides a first-mover advantage to the firms by getting ahead of other firms (23). Hence, based on this literature, we conclude the following hypothesis:

**H1:** *Sustainable supply chain strategy has a positive and significant impact on sustainable competitive advantage.*

### Sustainable Supply Chain Strategy and Sustainable Supply Chain Practice

In recent years, the increasing environmental concerns have made the sustainability practices receive management attention. In the supply chain, ecological issues severely affect the value chain system, thus demanding the need for effective strategies and sustainability practices across the supply chain network. Therefore, today, numerous firms have adopted SSCS for improving ecological welfare. Given the articulation, the study shows that the firms' sustainability strategies reduce the environmental cost, thereby maximizing the social welfare with sustainable practices (24).

In particular, sustainable supply chain strategies assist the firms in attaining the sustainable triple-bottom-line dimension. In supply chain modeling, organizations' enduring plans and sustainable practices devote to improving the organizations' function. Perhaps, understanding this multi-dimensional sustainability helps companies to support organizations' practices with a sustainability vision. The firms' sustainability strategies lead to the effective implementation of sustainable practices. For this reason, many companies have started embracing the concept of sustainable practices complementing the firms' sustainable goals (3). In the illustration, the study shows that the SSCP makes the organizations achieve the sustainability objectives by exhibiting superior organizational performances (25).

Arguably, many issues elevate the demand for sustainable approaches. In the pharmaceutical industry, to reach sustainability standards, companies have realized the need for sustainability practices to accomplish a business goal. The effort to improve the competitiveness in the pharmaceutical industry has made the organizations implement sustainability practices, significantly minimizing the increasing impact of ecological concerns (i.e., chemical waste, inhibitors) (25). In particular, according to the world health organization, the support of environmentally friendly strategic plans, strategies, practices, and policies help the organization guide the management, thus securing the environment (26). Consequently, based on the prior consideration, we have developed the following hypothesis:

**H2:** *Sustainable supply chain strategy has a positive and significant impact on sustainable supply chain practice.*

### Sustainable Supply Chain Practice and Sustainable Competitive Advantage

Over the past decades, environmental sustainability has received increasing significance in supply chain management. In recent years, the high escalation of environmental deterioration has made the stakeholders adopt eco-friendly practices for securing the long-term advantage. The firms' sustainable characteristics (e.g., actions, policies, processes) help firms to obtain a sustainable competitive advantage. Given the articulation, the study shows that the adoption of SSCP makes the companies encompass the sustainability dimensions, thus exhibiting high competitiveness and superior organizational performance (27).

Undoubtedly, competition is the most influential driver for incorporating sustainability in the supply chain. Organizations under its influence feel the pressure of adopting sustainable practices for gaining a competitive edge. The sustainable competitive advantage makes firms differentiate themselves from their rivals. Indeed, SSCP plays a vital role in maintaining market competitiveness. The sustainability practices enable the organizations to outperform their competitors by focusing on long-term stability. Given the illustration, the study found that sustainable supply chain practices provide the company with a sustainable competitive advantage with improved organizational performance (28).

However, the business's success largely depends on the firms' competitive benefit. By embedding the sustainability practices into firms' functions, the organizations can maintain a differential edge over its peer. Accordingly, the research shows that the SSCP enhances the firms' strategic assets, thus leading to SCA (29). Indeed, the supply chain sustainability practice leverages the firms' operations by providing competitive benefits. Therefore, due to its increasing significance (i.e., SSCP), the study suggests that companies should focus on sustainability practices to maintain a differential advantage over the other firms' (30). Therefore, based on these systematic reviews, our hypothesis states:

**H3:** *Sustainable supply chain practice has a positive and significant impact on sustainable competitive advantage.*

## The Mediating Role of Sustainable Supply Chain Practices

Today, numerous organizations are increasingly facing challenges regarding environmental deterioration. In such a situation, the sustainability practices potentially help the companies to neutralize the prevailing damage. Significantly, the collaborative supply chain network exhibiting sustainability development had reduced the ecological footprint spoiling the motherland. Indeed, building on this concept, organizations' have ensured establishing supply chain sustainability on multiple levels for gaining sustainable competitive advantage (31). Given the illustration, the study showed that the supply chain had highlighted the demand for incorporating the sustainable agenda in the business strategy, thereby exploring the market benefits, performance indicators, and sustainable advantage (32).

However, investigating this agenda in the pharmaceutical company shows that SSCS makes the firms acquire long-term stability and competitive advantage (33) with cleaner practices. This strategy of boosting the firm's sustainability performance helps the organization recognize the significance of developing sustainable supply chain practices. However, developing sustainable supply chain strategies ensures the development of sustainable practices, capabilities, and processes driving the competitive advantage. Given the illustration, the study shows that SSCS provides an enduring edge to organizations by ensuring cleaner production practices (34). The implementation of sustainable practices varies from organization to organization. Sustainable practices improve the firms' vision,

thus achieving higher competitive standards (35). In particular, the sustainability practices enable the firms to take over the market competition by providing a sustainable competitive edge. Hence, from the prior study findings, we have inferred the following hypothesis:

**H3a:** *Sustainable supply chain practice mediates the relationship between sustainable supply chain strategy and sustainable competitive advantage.*

## The Moderating Role of Sustainability Inhibitors

The international supply chain has increasingly faced environmental issues that need human visibility. In particular, these complexities have facilitated the need for environmentally friendly approaches to balance the ecological footprint (36). Ecological sustainability demands adopting sustainable practices as the motivators for combating the barriers (i.e., unsustainable inhibitors). Unsurprisingly, the pharmaceutical industry is colossally affected by the adversity of intoxicate inhibitors, which forms the foundation of poor economic stability. Given the explanation, the study reveals that for combating the unsustainable inhibitors, eco-friendly tools (e.g., technology) had widely adopted, reducing the ecological waste, potentially fulfilling is the fundamental goal of firms' strategy (37).

Indeed, today organizations have widely emphasized the implementation of sustainable inhibitors as a part of the firms' strategy. Given the articulation, the study findings suggest that management should invest in sustainable supply chain practices (38) to minimize the adversity of unsustainable pollutants. In contrast, the study shows that the sustainable supply chain practice provides a theoretical lens to the firms' enabling them to relish the benefit of sustainability inhibitors (39). Accordingly, in the supply chain, the pharmaceutical industry produces considerable waste throughout the production process. This excessive ecological burden (e.g., drugs and intoxicants) makes the managers implement sustainability inhibitors throughout the manufacturing process. The pharmaceutical model of sustainability practices reduces the effect of non-value additions activities, thus eliminating the waste. Given the illustration, the study states that the sustainability inhibitors drive the sustainability practices (40) to improve the socio-ecological welfare. Subsequently, the hypothesis built on the above consideration concludes:

**H4:** *Sustainability inhibitors strengthen or moderate the relationship between sustainable supply chain strategy and sustainable supply chain practice.*

**Figure 1** shows the study's theoretical framework (independent, dependent, mediator, and moderator variables).

## STUDY METHODOLOGY

### Sample and Data Collection

The research adopted a survey research design to collect data to investigate the influence of sustainable supply chain strategy on sustainable competitive advantage, mediating the role of sustainable supply chain practice and moderating the role of Sustainability Inhibitors. Through the convenience

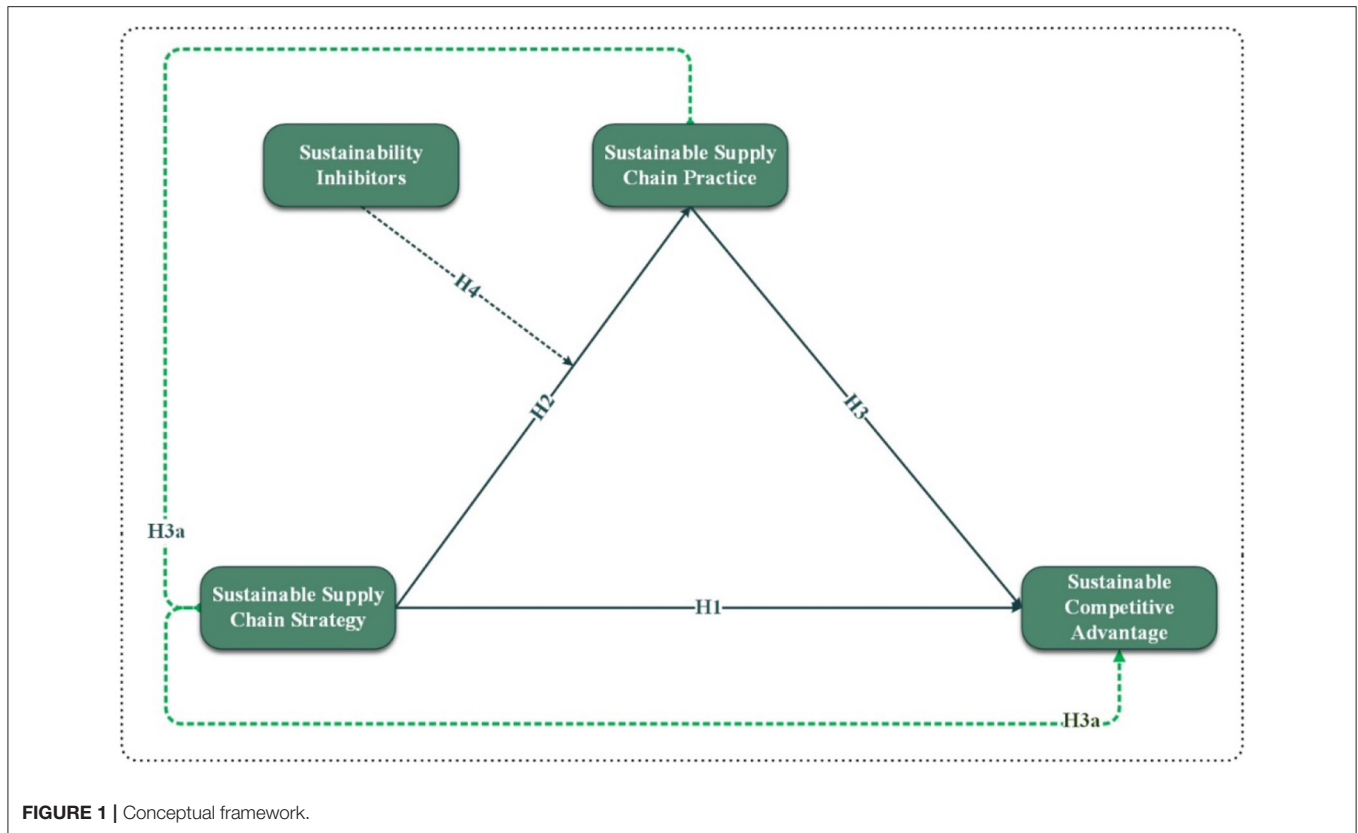

FIGURE 1 | Conceptual framework.

sample technique, questionnaires were distributed among the managers of 25 pharmaceutical companies located in Pakistan; data was collected from January-February 2022. Approximately 250 managers were contacted and requested to participate in this time-lagged study, whereas 180 complete responses were received.

To control the common method bias, this research conducted a time-lagged study with 15 days intervals. Responses on sustainable supply chain strategy and sustainability inhibitors were collected at time 1; after a gap of 15 days, responses on sustainable supply chain practice were collected, i.e., time-2; and after a gap of 15 days, data was collected on sustainable competitive advantage, i.e., time-3. This research also applied the common method bias using Harman's single-factor approach. The variance extracted using one factor is 6.835%, less than 50%, indicating no common method bias in this study (41). **Table 1** depicts the demographic characteristics of the study participants, revealing 52% male and 48% female. In total 13% of participants were in the age group 19–30; 28% were from 31–40. In total 36% of participants were Bachelor's degree holders, and 36% were master's.

## Measures

Sustainable supply chain strategy was measured using 3 item scale developed by Nayal et al. (42). Sample items include: "The industry markets the same products with minor variations as per consumer demand and trends of the market";

TABLE 1 | Demographic characteristics.

Items	Frequency (N = 180)	(%)
<b>Gender</b>		
Male	94	52.2
Female	86	47.8
<b>Age</b>		
19–30	24	13.3
31–40	48	26.7
41–50	50	27.8
51–60	32	17.8
>60	26	14.4
<b>Education</b>		
Intermediate	35	19.4
Bachelor	64	35.6
Master	64	35.6
MPhil/Others	17	9.4
<b>Marital status</b>		
Single	34	18.9
Married	146	81.1

"The industry has relevant IT-related knowledge and skills to adapt to recent sustainable market trends." Sustainability inhibitors was measured using 5 item scale developed by Gopal and Thakkar (43). Sample items include: "Resistance

**TABLE 2** | Model fit and reliability and validity analysis.

Model fit Indexes					
Fit Index	Cited	Fit criteria	Results	Fit (Yes/No)	
X2			131.771		
DF			129		
X2/DF	(44)	1.00–5.00	1.021		Yes
RMSEA	(45)	<0.08	0.011		Yes
SRMR	(46)	<0.08	0.0394		Yes
NFI	(47)	>0.80	0.938		Yes
IFI	(48)	>0.90	0.999		Yes
TLI	(49)	>0.90	0.998		Yes
CFI	(50)	>0.90	0.999		Yes

Alpha, composite reliability and validity analysis					
Construct	Items	Loading >0.704	Alpha >0.7	CR >0.7	AVE >0.5
Sustainable supply chain strategy	SSCS_1	0.797	0.862	0.862	0.676
	SSCS_2	0.851			
	SSCS_3	0.818			
Sustainable supply chain practice	SSCP_1	0.800	0.896	0.897	0.635
	SSCP_2	0.822			
	SSCP_3	0.799			
	SSCP_4	0.797			
	SSCP_5	0.764			
Sustainable competitive advantage	SCA_1	0.832	0.915	0.915	0.683
	SCA_2	0.811			
	SCA_3	0.827			
	SCA_4	0.844			
	SCA_5	0.818			
Sustainability inhibitors	SL_1	0.782	0.893	0.893	0.625
	SL_2	0.793			
	SL_3	0.793			
	SL_4	0.796			
	SL_5	0.789			

to technology advancement adoption” and “Unawareness of customers.” The dependent variable sustainable competitive advantage was measured using Nayal et al. (42) developed using a five-item scale. Sample items include: “Application of digital technologies and collaboration improves process efficiency”; “The digitalized Supply Chain responsible for improved collaboration and coordination improves flexibility.” Five-point Likert scale ranging from strongly disagree to strongly agree was used to measure the study variables. The mediating variable of sustainable supply chain practice was measured using a five-item scale developed by Gopal and Thakkar (43). It was measured using five Likert scales ranging from 1-not at all implemented to 5-fully implemented. Sample items include: “Lean practices” and “Eco-design practices.”

## Assessment of Model Fit and Measurement Model

Data cleaning and screening were performed before conducting the reliability and validity analysis. **Table 2** depicts the results of model fit, reliability, and validity analysis. Results of CFA- four-factor model depicts values within the acceptable range CFI =

0.999; TLI = 0.998; SRMR = 0.0394; NFI = 0.938; RMSEA = 0.011; hence confirming model fitness.

**Figure 2** depicts the CFA - measurement model with a factor loading of each item above 0.4 (as shown in **Table 2**), confirming convergent and content validity.

## RESULTS

Results of descriptive statistics (mean and standard deviation) correlation and discriminant validity analysis of the study variables are reported in **Table 3**. The result depicts values within the range as suggested by Hair (51). As shown sustainable competitive advantage is significantly related to sustainable supply chain strategy ( $r = 0.641, p < 0.05$ ), sustainable supply chain practice ( $r = 0.594, p < 0.05$ ) and sustainability inhibitors ( $r = -0.239, p < 0.05$ ). Similarly, sustainable supply chain strategy is significantly related to sustainable supply chain practice ( $r = 0.607, p < 0.05$ ) and sustainability inhibitors ( $r = 0.142, p < 0.05$ ).

## Hypothesis Testing

Results of hypothesis H1 H2, H3, and H3a (mediation analysis) is shown in **Table 4**. Hypothesis 1 states that sustainable supply

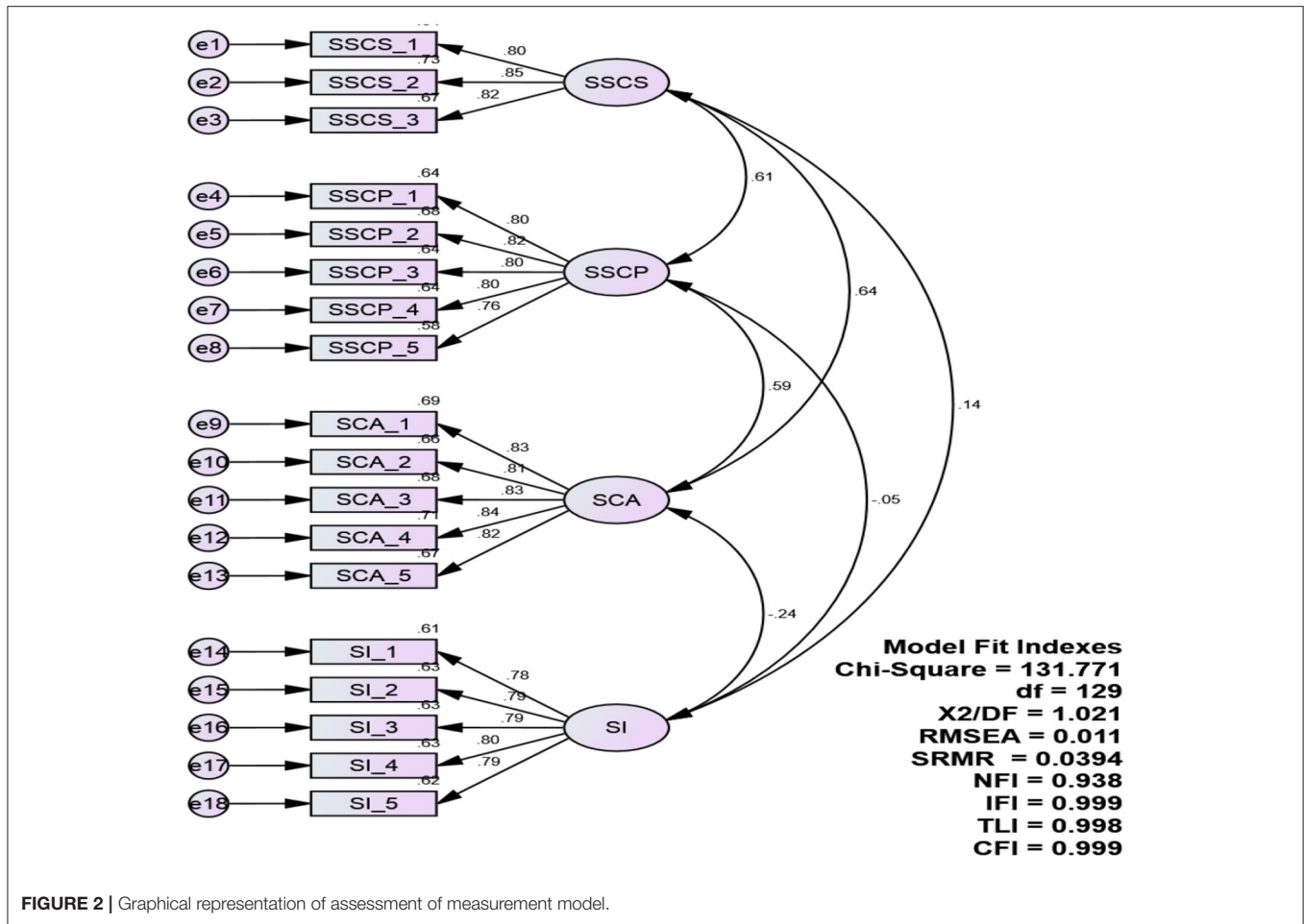

FIGURE 2 | Graphical representation of assessment of measurement model.

TABLE 3 | Discriminant validity analysis (Fornel Larcker and HTMT).

Constructs	Mean	SD	1	2	3	4
1. Sustainable competitive advantage	3.44	1.026	(0.826)			
2. Sustainable supply chain strategy	3.38	0.854	0.641**	(0.822)		
3. Sustainable supply chain practice	3.21	0.919	0.594**	0.607**	(0.797)	
4. Sustainability inhibitors	3.29	0.852	-0.239**	0.142**	-0.054**	(0.791)

\*Indicates significant paths: \*\* $p < 0.001$ .

chain strategy is positively related to sustainable competitive advantage with  $\beta = 0.484, p < 0.001$ ; Hypothesis 2 states that sustainable supply chain strategy is positively related to sustainable supply chain practices with  $\beta = 0.693, p < 0.001$ ; whereas Hypothesis 3 states that sustainable supply chain practices are positively related to sustainable competitive advantage with  $\beta = 0.320, p < 0.001$ . Hence Hypothesis 1, 2, and 3 are statistically proven. For mediation analysis, indirect effects were calculated. Table 4 shows that sustainable supply chain practices mediate the relationship between sustainable supply chain strategy and sustainable competitive advantage with  $\beta = 0.222, p < 0.001$ . Hence hypothesis 3a is proved.

In line with hypothesis 4, the interaction term of sustainable supply chain strategy and sustainability inhibitors was significant ( $\beta = 0.315, p < 0.05$ ). Moreover,

TABLE 4 | Hypotheses testing direct and indirect effect.

Hypothesis	Direct relationships	Std. beta	Std. error	T values	P values
H1	SSCS → SCA	0.484	0.09	7.126	***
H2	SSCS → SSCP	0.693	0.04	13.846	***
H3	SSCP → SCA	0.32	0.082	4.713	***
H3a	SSCS → SSCP → SCA	0.222	0.067	3.313	***

\*Indicates significant paths: \*\*\* $p < 0.001$ .

Table 5 illustrates that the relationship between sustainable supply chain strategy and sustainable supply chain practices strengthens when sustainability inhibitors are low

**TABLE 5** | Interaction and conditional effects.

Hypothesis	Interaction effects	Std. Beta	Std. Error	T values	P values
H4	Interaction SSCS*SI→SSCP	0.315	0.0634	4.968	***
<b>Conditional effects</b>					
	Level of the moderator	Effects	Boot SE	LLCI	ULCI
	−1 Std Dev	0.976***	0.069	0.839	1.114
	Mean	0.693***	0.050	0.593	0.793
	+1 Std Dev	0.410***	0.070	0.271	0.547

\*Indicates significant paths: \*\*\* $p < 0.001$ .

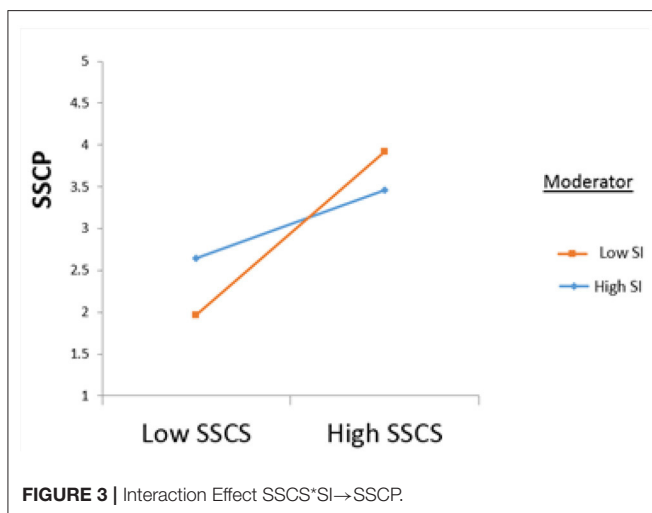
**FIGURE 3** | Interaction Effect SSCS\*SI→SSCP.

( $\beta = 0.976$ ,  $p < 0.001$ ). **Figure 3** shows the interaction effect of SSCS\*SI→SSCP.

## DISCUSSION

In recent years, sustainability has gained attention in business studies and practices because of rapidly decreasing reserves, concerns about wealth disparities, and firm social and environmental responsibilities (52–54). Intense pressure from various governmental authorities, consumers, suppliers, partners, and local and global communities has encouraged industries to include people, processes, and environmental issues in recent business operations (55). Sustainable supply chain management (SSCM) is a new and rapidly emerging study topic for scholars and practitioners (56). Previous literature reveals that organizations are developing and deploying the best strategies for implementing SSCM practices and policies. In this regard, an effort has been made in the current study to establish a comprehensive framework for assessing the relationship between strategies and performance, which may be valuable to practitioners and managers involved in the SSCM field. In short, this research investigates first: the relationship between sustainable supply chain strategy and sustainable competitive advantage; second: sustainable supply chain practices mediate the relationship between sustainable

supply chain strategy and sustainable competitive advantage; third: the moderating role of sustainability inhibitors between sustainable supply chain strategy and sustainable supply chain practices.

Mediation and moderation analyses were conducted using PLS-SEM to check the proposed hypothesis statistically. The results revealed that a sustainable supply chain strategy is positively and significantly associated with sustainable supply chain practices ( $\beta = 0.693$ ,  $p < 0.05$ ) and sustainable competitive advantage ( $\beta = 0.484$ ,  $p < 0.05$ ); sustainable supply chain practices are positively associated with sustainable competitive advantage ( $\beta = 0.320$ ,  $p < 0.05$ ). Henceforth hypotheses H1, H2, and H3 were accepted. Statistically, results revealed that sustainable supply chain practice mediates the relationship between sustainable strategy and competitive advantage; in addition, sustainability inhibitors moderate the relationship between sustainable supply chain strategy and practice. Hence Hypothesis H3a and H4 are approved.

## CONCLUSION

As a high pollutant with high waste and emission consumption industry, the sustainable strategy will help pharmaceutical supply chain managers improve their overall operations to become smarter, more adaptable, and sustainable in the long run, resulting in better company reputations and sustainable competitive advantages. In the current research, an attempt has been made to analyse the relationship between sustainable supply chain strategy, sustainability inhibitors, sustainable supply chain practices, and sustainable competitive advantage. The findings derived from statistical analysis reveal that sustainable supply chain practice mediates the relationship between sustainable supply chain strategy and sustainable competitive advantage. In contrast, sustainability inhibitors moderate the relationship between sustainable strategy and competitive advantage. This study will help managers in developing strategies that will promote sustainable supply chain strategies.

## DATA AVAILABILITY STATEMENT

The raw data supporting the conclusions of this article will be made available by the authors, without undue



reservation. The datasets used and/or analyzed during the current study are available from the corresponding author on reasonable request.

## ETHICS STATEMENT

Ethical review and approval was not required for the study on human participants in accordance with the local legislation and institutional requirements. The patients/participants provided their written informed consent to participate in this study.

## REFERENCES

- Ioannou I, Serafeim G. Corporate sustainability: a strategy? Working Paper No. 19-065. *Accounting and Management Unit, Harvard Business School*, Boston, MA, United States. (2019) 1–45. Available online at: [https://www.hbs.edu/ris/Publication%20Files/WP19-065rev4-23-21\\_aefe2c98-5fa6-44c4-bbae-f68e6f283642.pdf](https://www.hbs.edu/ris/Publication%20Files/WP19-065rev4-23-21_aefe2c98-5fa6-44c4-bbae-f68e6f283642.pdf)
- Qi Y, Huo B, Wang Z, Yeung HYJ. The impact of operations and supply chain strategies on integration and performance. *Int J Prod Econ.* (2017) 185:162–74. doi: 10.1016/j.ijpe.2016.12.028
- Luthra S, Mangla SK. When strategies matter: Adoption of sustainable supply chain management practices in an emerging economy's context. *Resour Conserv Recycl.* (2018) 138:194–206. doi: 10.1016/j.resconrec.2018.07.005
- Prajogo D, Mena C, Nair A. The fit between supply chain strategies and practices: a contingency approach and comparative analysis. *IEEE Trans Eng Manage.* (2018) 65:168–80. doi: 10.1109/TEM.2017.2756982
- Wang J, Zhang Y, Goh M. Moderating the Role of Firm Size in Sustainable Performance Improvement through. *Sustain Supply Chain Manag Sustainabil.* (2018) 10:1654. doi: 10.3390/su10051654
- Bag S, Gupta S, Foroopon C. Examining the role of dynamic remanufacturing capability on supply chain resilience in circular economy. *Manage Decis.* (2019) 57:863–85. doi: 10.1108/MD-07-2018-0724
- Amponsah CT, Ahmed G. New global dimensions of business excellence. *Int J Bus Excell.* (2017) 13:60. doi: 10.1504/IJBEX.2017.10006231
- Rezaee Z. Supply chain management and business sustainability synergy: a theoretical and integrated perspective. *Sustainability.* (2018) 10:275. doi: 10.3390/su10010275
- Kumar A, Zavadskas EK, Mangla SK, Agrawal V, Sharma K, Gupta D. When risks need attention: adoption of green supply chain initiatives in the pharmaceutical industry. *Int J Product Res.* (2019) 57:3554–76. doi: 10.1080/00207543.2018.1543969
- Alzoubi HM, Ahmed G, Al-Gasaymeh A, Al Kurdi B. Empirical study on sustainable supply chain strategies and its impact on competitive priorities: The mediating role of supply chain collaboration. *Manage Sci Lett.* (2020) 70:3–8. doi: 10.5267/j.msl.2019.9.008
- Singh RK, Koul S, Kumar P. Analyzing the interaction of factors for flexibility in supply chains. *J Model Manag.* (2017) 12:671–89. doi: 10.1108/JM2-04-2016-0039
- Ciccullo F, Pero M, Caridi M, Gosling J, Purvis L. Integrating the environmental and social sustainability pillars into the lean and agile supply chain management paradigms: a literature review and future research directions. *J Clean Prod.* (2018) 172:2336–50. doi: 10.1016/j.jclepro.2017.11.176
- Luthra S, Mangla SK, Shankar R, Prakash Garg C, Jakhar S. Modelling critical success factors for sustainability initiatives in supply chains in Indian context using Grey-DEMATEL. *Product Plan Control.* (2018) 29:705–28. doi: 10.1080/09537287.2018.1448126
- Zaid AA, Jaaron AAM, Talib Bon A. The impact of green human resource management and green supply chain management practices on sustainable performance: an empirical study. *J Clean Prod.* (2018) 204:965–79. doi: 10.1016/j.jclepro.2018.09.062
- Basik, M., and Mobin, M. (2022). Environmentally sustainable corrosion inhibitors in the oil and gas industry. In: *Environmentally Sustainable Corrosion Inhibitors*. pp. 405–421. Elsevier. doi: 10.1016/B978-0-323-85405-4.00017-3
- Verma C, Ebenso EE, Quraishi MA, Hussain CM. Recent developments in sustainable corrosion inhibitors: design, performance and industrial scale applications. *Mat Adv.* (2021) 2:3806–50. doi: 10.1039/D0MA00681E
- Hossain N, Asaduzzaman Chowdhury M, Kchaou M. An overview of green corrosion inhibitors for sustainable and environment friendly industrial development. *J Adhes Sci Technol.* (2021) 35:673–90. doi: 10.1080/01694243.2020.1816793
- Mani V, Gunasekaran A. Four forces of supply chain social sustainability adoption in emerging economies. *Int J Product Econ.* (2018) 199:150–61. doi: 10.1016/j.ijpe.2018.02.015
- Grover AK, Dresner M. A theoretical model on how firms can leverage political resources to align with supply chain strategy for competitive advantage. *J Supply Chain Manage.* (2022) 1–18. doi: 10.1111/jscm.12284
- Mackelprang AW, Bernardes E, Burke GJ, Welter C. Supplier innovation strategy and performance: a matter of supply chain market positioning. *Decis Sci.* (2018) 49:660–89. doi: 10.1111/dec.12283
- Zinn W, Goldsby TJ. Supply chain plasticity: redesigning supply chains to meet major environmental change. *J Bus Logist.* (2019) 40:184–6. doi: 10.1111/jbl.12226
- Hughes RC. Regulatory entrepreneurship, fair competition, and obeying the law. *J Bus Ethics.* (2021) 1–13. doi: 10.1007/s10551-021-04932-y. [Epub ahead of print].
- Garud R, Kumaraswamy A, Roberts A, Xu L. Liminal movement by digital platform-based sharing economy ventures: the case of Uber Technologies. *Strat Manage J.* (2022) 43:447–75. doi: 10.1002/smj.3148
- Nassibeh J, Zandieh M, Tabriz AA, Rabieh M. Designing sustainable distribution network in pharmaceutical supply chain: a case study. *Int J Supply Operat Manage.* (2018) 5:122–33. doi: 10.22034/2018.2.2
- Ahmad F, Alnowibet KA, Alrashedi AF, Adhami AY. A multi-objective model for optimizing the socio-economic performance of a pharmaceutical supply chain. *Socio-Econ Plan Sci.* (2022) 79:101126. doi: 10.1016/j.seps.2021.101126
- WHO. (2019). Annual Report 2018. *Alliance For Health Policy and System Reserach.*
- Das D. The impact of Sustainable Supply Chain Management practices on firm performance: lessons from Indian organizations. *J Clean Prod.* (2018) 203:179–96. doi: 10.1016/j.jclepro.2018.08.250
- Mukhsin M, Suryanto T. The effect of sustainable supply chain management on company performance mediated by competitive advantage. *Sustainability.* (2022) 14:818. doi: 10.3390/su14020818
- Tripathi G, Joshi S. Creating competitive advantage through sustainable supply chains: a theoretical framework for the assessment of practices, dynamic capabilities, and enterprise performance of manufacturing firms. *Int J Recent Technol Eng.* (2019) 8:7863–75. doi: 10.35940/ijrte.D9501.118419
- Ahmadi-Gh Z, Bello-Pintado A. Why is manufacturing not more sustainable? The effects of different sustainability practices on sustainability outcomes and competitive advantage. *J Cleaner Production.* (2022) 337:130392. doi: 10.1016/j.jclepro.2022.130392

## AUTHOR CONTRIBUTIONS

All authors listed have made a substantial, direct, and intellectual contribution to the work and approved it for publication.

## FUNDING

We acknowledge the financial support from the National Natural Science Foundation of China (Grant No: 71974102) and from the Philosophy; Social Science Fund of Tianjin City, China (Grant No: TJYJ20-012).

31. van der Heijden A, Cramer JM. Change agents and sustainable supply chain collaboration: A longitudinal study in the Dutch pig farming sector from a sensemaking perspective. *J Clean Prod.* (2017) 166:967–87. doi: 10.1016/j.jclepro.2017.08.074
32. Teixeira AA, Moraes TE, Stefanelli NO, de Oliveira JH, Teixeira TB, de Souza Freitas WR. Green supply chain management in Latin America: systematic literature review and future directions. *Environ Quality Manage.* (2020) 30:47–73. doi: 10.1002/tqem.21712
33. Ding B. Pharma Industry 4.0: Literature review and research opportunities in sustainable pharmaceutical supply chains. *Process Safety Environ Protect.* (2018) 119:115–130. doi: 10.1016/j.psep.2018.06.031
34. Rani S, Ali R, Agarwal A. Fuzzy inventory model for deteriorating items in a green supply chain with carbon concerned demand. *OPSEARCH.* (2019) 56:91–122. doi: 10.1007/s12597-019-00361-8
35. Schaltegger S, Hörisch J, Freeman RE. Business cases for sustainability: a stakeholder theory perspective. *Organiz Environ.* (2019) 32:191–212. doi: 10.1177/1086026617722882
36. Allaoui H, Guo Y, Sarkis J. Decision support for collaboration planning in sustainable supply chains. *J Clean Prod.* (2019) 229:761–74. doi: 10.1016/j.jclepro.2019.04.367
37. Karuppiyah K, Sankaranarayanan B, Ali SM, Jabbar CJC, Bhalaji RKA. Inhibitors to circular economy practices in the leather industry using an integrated approach: Implications for sustainable development goals in emerging economies. *Sustain Product Consumpt.* (2021) 27:1554–68. doi: 10.1016/j.spc.2021.03.015
38. Shaw S, Grant DB, Mangan J. A supply chain practice-based view of enablers, inhibitors and benefits for environmental supply chain performance measurement. *Product Plann Control.* (2021) 32:382–96. doi: 10.1080/09537287.2020.1737977
39. Mishra D, Gunasekaran A, Papadopoulos T, Hazen B. Green supply chain performance measures: A review and bibliometric analysis. *Sustain Product Consumpt.* (2017) 10:85–99. doi: 10.1016/j.spc.2017.01.003
40. Venugopal V, Saleeshya PG. Manufacturing system sustainability through lean and agile initiatives. *Int J Sustain Eng.* (2019) 12:159–73. doi: 10.1080/19397038.2019.1566411
41. Podsakoff PM, MacKenzie SB, Lee J-Y, Podsakoff NP. Common method biases in behavioral research: A critical review of the literature and recommended remedies. *J Appl Psychol.* (2003) 88:879. doi: 10.1037/0021-9010.88.5.879
42. Nayal K, Raut RD, Yadav VS, Priyadarshinee P, Narkhede BE. The impact of sustainable development strategy on sustainable supply chain firm performance in the digital transformation era. *Bus Strat Environ.* (2022) 31:845–59. doi: 10.1002/bse.2921
43. Gopal PRC, Thakkar J. Sustainable supply chain practices: an empirical investigation on Indian automobile industry. *Product Plan Control.* (2016) 27:49–64. doi: 10.1080/09537287.2015.1060368
44. Kline RB. *Principles and Practice for Structural Equation Modelling (3rd Eds)*. New York, NY: Guildford Press. (2010).
45. Steiger JH. Structural model evaluation and modification: an interval estimation approach. *Multivariate Behav Res.* (1990) 25:173–80. doi: 10.1207/s15327906mbr2502\_4
46. Hu L, Bentler PM. Cutoff criteria for fit indexes in covariance structure analysis: Conventional criteria versus new alternatives. *Struct Equat Model.* (1999) 6:1–55. doi: 10.1080/10705519909540118
47. Bentler PM, Bonett DG. Significance tests and goodness of fit in the analysis of covariance structures. *Psychol Bull.* (1980) 88:588. doi: 10.1037/0033-2909.88.3.588
48. Bollen KA. Overall fit in covariance structure models: two types of sample size effects. *Psychol Bull.* (1990) 107:256. doi: 10.1037/0033-2909.107.2.256
49. Tucker LR, Lewis C. A reliability coefficient for maximum likelihood factor analysis. *Psychometrika.* (1973) 38:1–10. doi: 10.1007/BF02291170
50. Byrne BM. *Structural Equation Modeling With Mplus: Basic Concepts, Applications, and Programming*. Routledge. (2013). doi: 10.4324/9780203807644
51. Hair JF. In: Black WC, Babin BJ, Anderson RE. *Multivariate Data Analysis, a Global Perspective*. New Jersey: Pearson. Ed, 7, 816. (2010).
52. Harangozó G, Zilahy G. Cooperation between business and non-governmental organizations to promote sustainable development. *J Clean Product.* (2015) 89:18–31. doi: 10.1016/j.jclepro.2014.10.092
53. Koberg E, Longoni A. A systematic review of sustainable supply chain management in global supply chains. *J Clean Prod.* (2019) 207:1084–98. doi: 10.1016/j.jclepro.2018.10.033
54. Mangla S, Madaan J, Chan FTS. Analysis of flexible decision strategies for sustainability-focused green product recovery system. *Int J Product Res.* (2013) 51:3428–42. doi: 10.1080/00207543.2013.774493
55. Masoumik SM, Abdul-Rashid SH, Olugu EU. Gaining competitive advantage through strategic green supply chain management: From a literature review towards a conceptual model. *Int J Supply Chain Manage.* (2014) 3:49–58.
56. Varsei M, Soosay C, Fahimnia B, Sarkis J. Framing sustainability performance of supply chains with multi-dimensional indicators. *Supply Chain Manage Int J.* (2014) 19:242–57. doi: 10.1108/SCM-12-2013-0436

**Conflict of Interest:** The authors declare that the research was conducted in the absence of any commercial or financial relationships that could be construed as a potential conflict of interest.

**Publisher's Note:** All claims expressed in this article are solely those of the authors and do not necessarily represent those of their affiliated organizations, or those of the publisher, the editors and the reviewers. Any product that may be evaluated in this article, or claim that may be made by its manufacturer, is not guaranteed or endorsed by the publisher.

Copyright © 2022 Sun, Sarfraz, Khawaja and Abdullah. This is an open-access article distributed under the terms of the Creative Commons Attribution License (CC BY). The use, distribution or reproduction in other forums is permitted, provided the original author(s) and the copyright owner(s) are credited and that the original publication in this journal is cited, in accordance with accepted academic practice. No use, distribution or reproduction is permitted which does not comply with these terms.