



OPEN ACCESS

EDITED AND REVIEWED BY
Yongliang Qiao,
The University of Sydney, Australia

*CORRESPONDENCE

Ning Yang
✉ yangn@ujs.edu.cn
Sanling Fu
✉ fusanling@126.com

SPECIALTY SECTION

This article was submitted to
Sustainable and Intelligent
Phytoprotection,
a section of the journal
Frontiers in Plant Science

RECEIVED 08 November 2022

ACCEPTED 06 December 2022

PUBLISHED 21 December 2022

CITATION

Zhang F, Cao W, Wang S, Cui X,
Yang N, Wang X, Zhang X and Fu S
(2022) Corrigendum: Improved
YOLOv4 recognition algorithm for
pitaya based on coordinate attention
and combinational convolution.
Front. Plant Sci. 13:1092374.
doi: 10.3389/fpls.2022.1092374

COPYRIGHT

© 2022 Zhang, Cao, Wang, Cui, Yang,
Wang, Zhang and Fu. This is an open-
access article distributed under the
terms of the [Creative Commons
Attribution License \(CC BY\)](#). The use,
distribution or reproduction in other
forums is permitted, provided the
original author(s) and the copyright
owner(s) are credited and that the
original publication in this journal is
cited, in accordance with accepted
academic practice. No use,
distribution or reproduction is
permitted which does not comply with
these terms.

Corrigendum: Improved YOLOv4 recognition algorithm for pitaya based on coordinate attention and combinational convolution

Fu Zhang^{1,2}, Weihua Cao¹, Shunqing Wang¹, Xiahua Cui¹,
Ning Yang^{3*}, Xinyue Wang¹, Xiaodong Zhang⁴
and Sanling Fu^{5*}

¹College of Agricultural Equipment Engineering, Henan University of Science and Technology, Luoyang, China, ²Collaborative Innovation Center of Machinery Equipment Advanced Manufacturing of Henan Province, Henan University of Science and Technology, Luoyang, China,

³School of Electrical and Information Engineering, Jiangsu University, Zhenjiang, China, ⁴Key Laboratory of Modern Agricultural Equipment and Technology of Ministry of Education, Jiangsu University, Zhenjiang, China, ⁵College of Physical Engineering, Henan University of Science and Technology, Luoyang, China

KEYWORDS

improved YOLOv4, GhostNet, coordinate attention, improved combinational convolution module, target recognition

A corrigendum on

Improved YOLOv4 recognition algorithm for pitaya based on coordinate attention and combinational convolution

by Zhang F, Cao W, Wang S, Cui X, Yang N, Wang X, Zhang X and Fu S (2022) *Front. Plant Sci.* 13:1030021. doi: 10.3389/fpls.2022.1030021

In the published article, there was an error in [Figure 2](#) as published. An error appears in the upper left corner of the figure. The corrected [Figure 2](#) and its caption YOLOv4 network structure diagram. * means repeat the operation. appear below.

In the published article, there was an error in [Figure 6](#) as published. The left side of the figure is missing. The corrected [Figure 6](#) and its caption Improved combinational convolution-CA module at fusion. appear below.

In the published article, there was an error in [Figure 10](#) as published. An error appears in the upper left corner of the figure. The corrected [Figure 10](#) and its caption The improved YOLOv4 network structure diagram. * means repeat the operation. appear below.

The authors apologize for this error and state that this does not change the scientific conclusions of the article in any way. The original article has been updated.

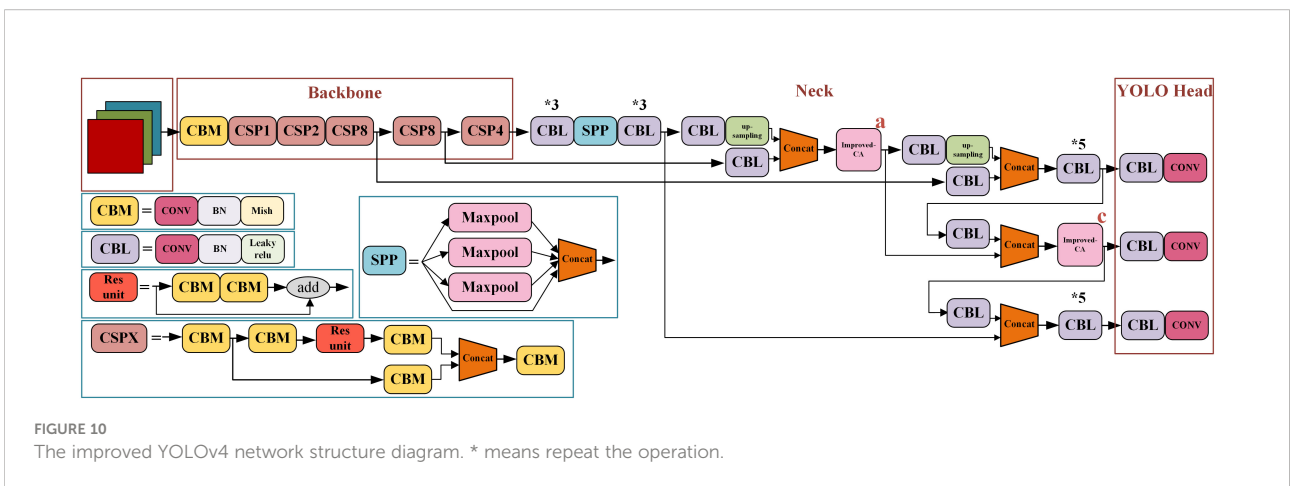
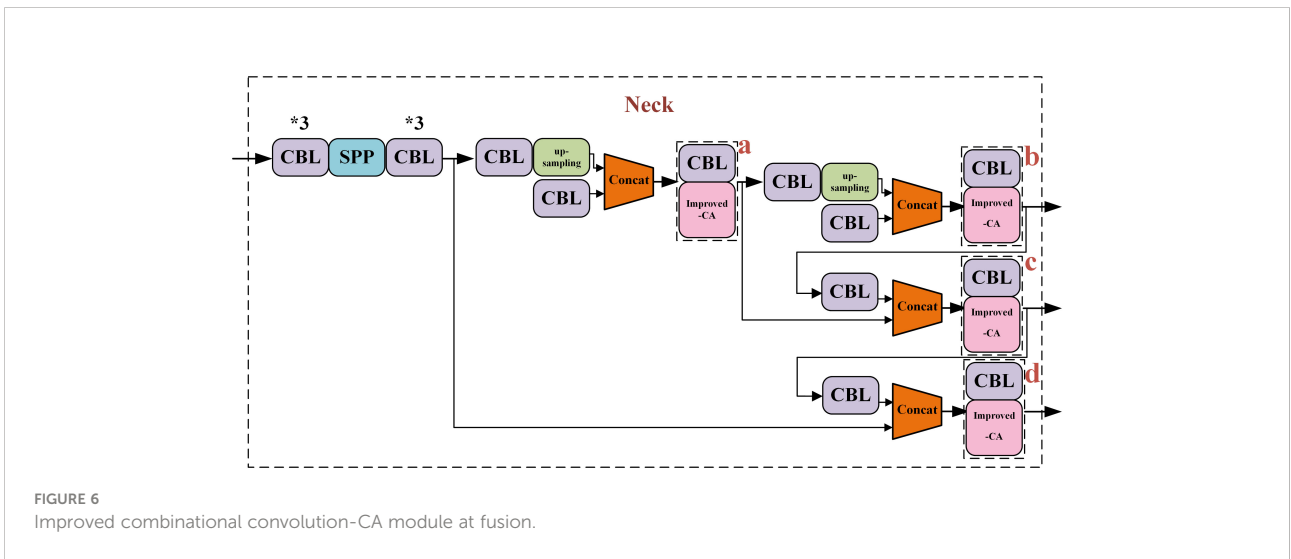
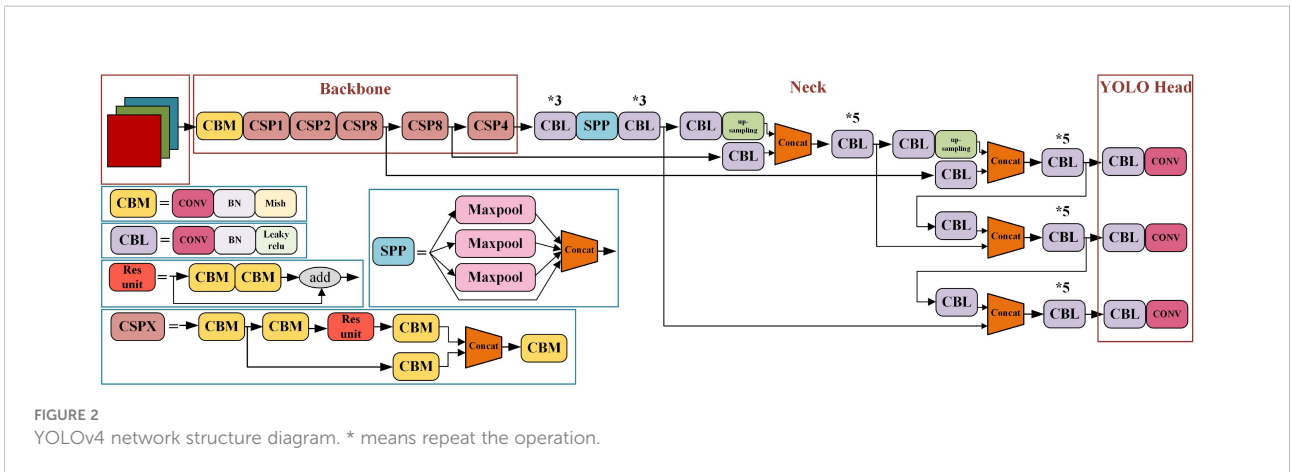

Publisher's note

All claims expressed in this article are solely those of the authors and do not necessarily represent those of their affiliated

organizations, or those of the publisher, the editors and the reviewers. Any product that may be evaluated in this article, or claim that may be made by its manufacturer, is not guaranteed or endorsed by the publisher.