



OPEN ACCESS

EDITED BY

Yunlong Shang,
Shandong University, China

REVIEWED BY

Longxing Wu,
Xi'an University of Technology, China
Wenhua Zuo,
Helmholtz-Institut Ulm, Germany

*CORRESPONDENCE

Shulin Liu,
shulin1023@sina.com

SPECIALTY SECTION

This article was submitted to
Electrochemical Energy Conversion and
Storage,
a section of the journal
Frontiers in Energy Research

RECEIVED 19 July 2022

ACCEPTED 29 August 2022

PUBLISHED 06 January 2023

CITATION

Guo J, Liu S and Zhu R (2023), An
unscented kalman filtering method for
estimation of state-of-charge of
lithium-ion battery.
Front. Energy Res. 10:998002.
doi: 10.3389/fenrg.2022.998002

COPYRIGHT

© 2023 Guo, Liu and Zhu. This is an
open-access article distributed under
the terms of the [Creative Commons
Attribution License \(CC BY\)](https://creativecommons.org/licenses/by/4.0/). The use,
distribution or reproduction in other
forums is permitted, provided the
original author(s) and the copyright
owner(s) are credited and that the
original publication in this journal is
cited, in accordance with accepted
academic practice. No use, distribution
or reproduction is permitted which does
not comply with these terms.

An unscented kalman filtering method for estimation of state-of-charge of lithium-ion battery

Jishu Guo¹, Shulin Liu^{2*} and Rui Zhu³

¹School of Information and Automation Engineering, Qilu University of Technology (Shandong Academy of Sciences), Jinan, China, ²School of Automation and Electrical Engineering, Linyi University, Linyi, China, ³School of Information Science and Engineering, Shandong Normal University, Jinan, China

Accurate estimation of battery state of charge (SOC) is of great significance to improve battery management and service life. An unscented Kalman filter (UKF) method is used to increase the accuracy of SOC estimation in this paper. Firstly, a battery model that the parameters are identified by using the least squares algorithm is established, which is foundation of the two-order RC equivalent circuit model. Secondly, SOC is estimated by UKF. In order to validate the method, experiments have been carried out under different operating conditions for LiFePO₄ batteries. The obtained results are compared with that of the extended Kalman filter. Finally, the comparison shows that the UKF method provides better accuracy in the battery SOC estimation. Its estimation error is less than 2%, which is better than EKF algorithm. An effective method is provided for state estimation for battery management system.

KEYWORDS

EKF, UKF, SOC estimation, lithium-ion battery, model

1 Introduction

As the power source of electric vehicle, power battery plays a core role in electric vehicle. Its performance is closely related to the braking energy recovery rate, driving range and acceleration performance of the whole vehicle. The key role of power battery in electric vehicles is to provide electric vehicles with strong climbing ability, acceleration ability and endurance ability. The specific power of the battery determines the starting, acceleration, climbing performance and the maximum speed performance of the electric vehicle. Power battery is the core component of electric vehicle energy storage system. Lithium-ion batteries have been widely used in electric vehicles because of its obvious advantages in performance, capacity, service life and so on (Chen et al., 2019; Shuzhi et al., 2021). Lithium-ion batteries include ternary material batteries, lithium-iron phosphate batteries and lithium manganese acid batteries (Li et al., 2017). Lithium-rich oxides have been considered as promising cathodes for the next generation power batteries (Yang et al., 2020). Lithium-iron phosphate batteries are widely used in electric vehicles because

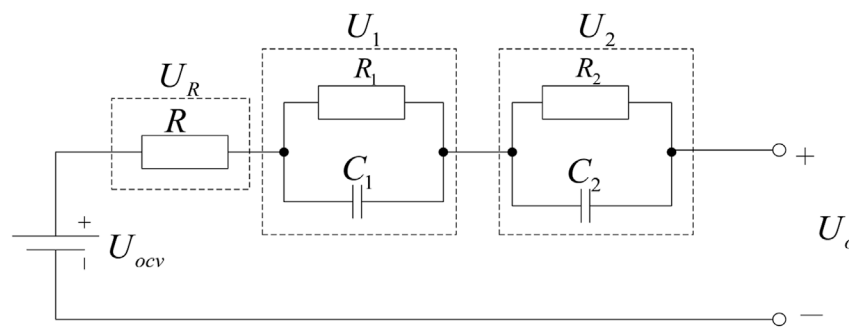

FIGURE 1
The two-order RC equivalent circuit model.

of their non-toxic, pollution-free, good safety performance. However, the accidents caused by fire, combustion and explosion of power batteries at home and abroad in recent years fully illustrate that once the hidden danger of battery safety breaks out, its harmfulness is difficult to measure. And strong measures must be taken to prevent the accidents that may be caused by the hidden danger of battery safety. Therefore, the significance of efficient management of battery system for electric vehicles is highlighted and has attracted much attention. It has become a hot issue in scientific research in related fields, and it is also a difficulty in technical development.

The model of power battery is to describe the mathematical relationship between voltage, current, state of charge (SOC) and other parameters in the working process (Gao et al., 2018; Zheng et al., 2018). At present, there are four kinds of commonly used battery models: neural network model, electrochemical model, AC impedance model and equivalent circuit model. Equivalent circuit model plays an important role in battery state estimation. SOC estimation of lithium-ion power battery is one of the important links in battery management system. SOC is one of the parameters characterizing the working state of power battery, which can provide basis for battery management. (Singh et al., 2020; Yang et al., 2020; Zuo et al., 2022).

The electrochemical model of power battery mainly reflects the internal electrochemical reaction process, and uses mathematical formulas to describe the battery characteristics (Li et al., 2020; Zuo et al., 2020). The model is closely related to battery materials, formulas and processes, and the calculation of parameters is complex. The simplified electrochemical model can predict the change of voltage and residual electricity. The classical electrochemical simplified models mainly include single particle model (SPM) and single particle model incorporating electrolyte physics (SPMe) (Wu et al., 2021). Neural network model can accurately describe the dynamic characteristics of power battery, and takes a large number of battery test data as training data (Yang et al., 2019; Feng et al., 2020; Shen et al., 2020). But the neural network also has some shortcomings. It needs a lot of training data to increase the accuracy of the model, and the model error is easily affected by the training

data and training methods. The AC impedance model is established based on the AC impedance characteristics and dynamic frequency characteristics of the battery. Zhu established the AC impedance model by using the battery impedance spectrum (Zhu et al., 2020). The battery model can accurately describe its impedance and electrochemical characteristics. However, the AC impedance spectrum and battery impedance are directly affected by the temperature and frequency. At the same time, the calculation of parameters in the model is complex. The equivalent circuit model is a circuit network composed of circuit elements (Tran et al., 2020). Such as resistance, capacitance and constant voltage source to describe the external characteristics of the battery. The physical meaning of the equivalent circuit model is clear. Considering the external characteristics such as voltage, current and temperature, it has good adaptability to the power battery under different working conditions. So it is widely used in power battery state estimation and battery management system.

At present, there are four main categories of SOC estimation methods proposed by domestic and foreign scholars (Zhao et al., 2018; Jiao et al., 2020): estimation methods based on A hour integral, estimation methods based on measured values of battery characterization parameters, estimation methods based on empirical equations and mathematical models, and estimation methods based on battery equivalent circuit model. Ampere hour integral is also called Coulomb counting method. This method is usually used as the reference SOC in the single discharge process of battery, which is common in practical application. The parameters such as residual capacity and open circuit voltage of power battery have a certain relationship with SOC (Kwak et al., 2019). These parameters are usually used to characterize battery SOC. SOC estimation methods based on empirical equation and mathematical model mainly include linear model method, neural network method, fuzzy logic method, support vector machine and so on (She et al., 2019; Cheng and Tingloang, 2020; Guo et al., 2021). The estimation methods based on battery equivalent circuit model mainly include Kalman filter, observer and particle filter (Peng et al., 2019). The observer method can increase the accuracy and robustness of SOC estimation, but the performance of this method will be greatly

affected by the noise. Unscented Kalman filter (UKF) is the combination of unscented transform (UT) and standard Kalman filter system. Through the lossless transform, the nonlinear system equation is suitable for the standard Kalman system under linear assumption. The UKF uses statistical linearization technology which is called linearization method unscented transformation. This technology linearizes the nonlinear function of random variables mainly through the linear regression of n points collected in *a priori* distribution. Considering the expansion of random variables, this linearization is more accurate than Taylor series linearization. This method has better accuracy than EKF in estimating SOC and error covariance.

2 Modeling of lithium-ion battery

2.1 Battery model

The equivalent circuit model is a circuit network composed of circuit elements such as resistance, capacitance and constant voltage source. The model is usually used to describe the relationship between the external characteristics such as terminal voltage, charge discharge current and working temperature of the battery. It is widely used in the research of power battery. Lithium-ion battery model should better reflect the dynamic characteristics of the battery and it can't be too complicated. Besides, the model should be easily used in engineering. Taking these factors into account, the two-order RC equivalent circuit model is established as the model of lithium-ion battery, as shown in Figure 1.

In Figure 1, U_0 is the terminal voltage of the battery, U_{ocv} is the battery open-circuit voltage, R is the battery internal resistance, R_1 , C_1 are diffusion resistance and diffusion capacitance respectively, R_2 , C_2 are concentration polarization resistance and concentration polarization capacitance respectively. According to Figure 1, the battery equivalent circuit mathematical model can be obtained as follows:

$$V_0 = V_{ocv} - V_R - V_1 - V_2 \tag{1}$$

$$\begin{cases} \dot{V}_1 = \frac{I}{C_1} - \frac{V_1}{R_1 C_1} \\ \dot{V}_2 = \frac{I}{C_2} - \frac{V_2}{R_2 C_2} \end{cases} \tag{2}$$

Where I represents the load current (negative for charge, positive for discharge).

By defining $E_t = V_0 - V_{ocv}$ and according to Eq. 1, the transfer function of the battery impedance can be written by Eq. 3.

$$G(s) = \frac{V_0(s) - V_{ocv}(s)}{I(s)} = \frac{E_t(s)}{I(s)} = -\left(R + \frac{R_1}{1 + R_1 C_1 s} + \frac{R_2}{1 + R_2 C_2 s} \right) \tag{3}$$

A bilinear transformation method shown in Eq. 4 is employed for the discretization calculation of Eq. 3, and the result is given by Eq. 5.

$$s = \frac{2}{T_s} \frac{1 - z^{-1}}{1 + z^{-1}} \tag{4}$$

Where the z is the discretization operator and the T_s is the sampling period with an interval of 1s.

$$G(z) = \frac{c_3 + c_4 z^{-1} + c_5 z^{-2}}{1 - c_1 z^{-1} - c_2 z^{-2}} \tag{5}$$

Then the parameters of the battery model can be solved by Eq. 6.

$$\begin{cases} R_0 = \frac{c_3 - c_4 + c_5}{c_2 - c_1 - 1} \\ \tau_1 + \tau_2 = -\frac{c_2 + 1}{c_1 + c_2 - 1} \\ \tau_1 \tau_2 = \frac{c_2 - c_1 - 1}{4(c_1 + c_2 - 1)} \\ R + R_1 + R_2 = \frac{c_3 + c_4 + c_5}{c_1 + c_2 - 1} \\ R(\tau_1 + \tau_2) + R_1 \tau_2 + R_2 \tau_1 = \frac{c_3 - c_5}{c_1 + c_2 - 1} \end{cases} \tag{6}$$

Eventually, the auto-regressive exogenous (ARX) form of the battery can be rewritten by

$$y_k = \varphi_k \theta_k \tag{7}$$

where the φ and the θ denote the data matrix and the parameter matrix respectively.

$$\begin{cases} \varphi_k = [E_{t,k-1} \ E_{t,k-2} \ I_k \ I_{k-1} \ I_{k-2}] \\ \theta_k = [c_1 \ c_2 \ c_3 \ c_4 \ c_5]^T \end{cases} \tag{8}$$

2.2 Model parameter identification method

In this paper, the least square algorithm with forgetting factor (FFRLS) is used to realize the dynamic identification of model

TABLE 1 Implementation process of the FFRLS algorithm.

1) Initialization.	
$\varphi_0, \theta_0, P_0, K_0, \lambda$	
2) Calculate algorithm gain K_k and error covariance matrix P_k .	
$P_k = \frac{P_{k-1} \varphi_k^T}{\varphi_k P_{k-1} \varphi_k^T + \lambda}$	(9)
$P_k = \frac{P_{k-1} - K_k \varphi_k^T P_{k-1}}{\lambda}$	(10)
3) Calculate prediction error and update model parameters.	
$e_k = E_{t,k} - \varphi_k \theta_{k-1}$	(11)
$\theta_k = \theta_{k-1} + K_k e_k$	(12)
4) Update the predicted terminal voltage.	
$E_{t,k} = \varphi_k \theta_k$	(13)

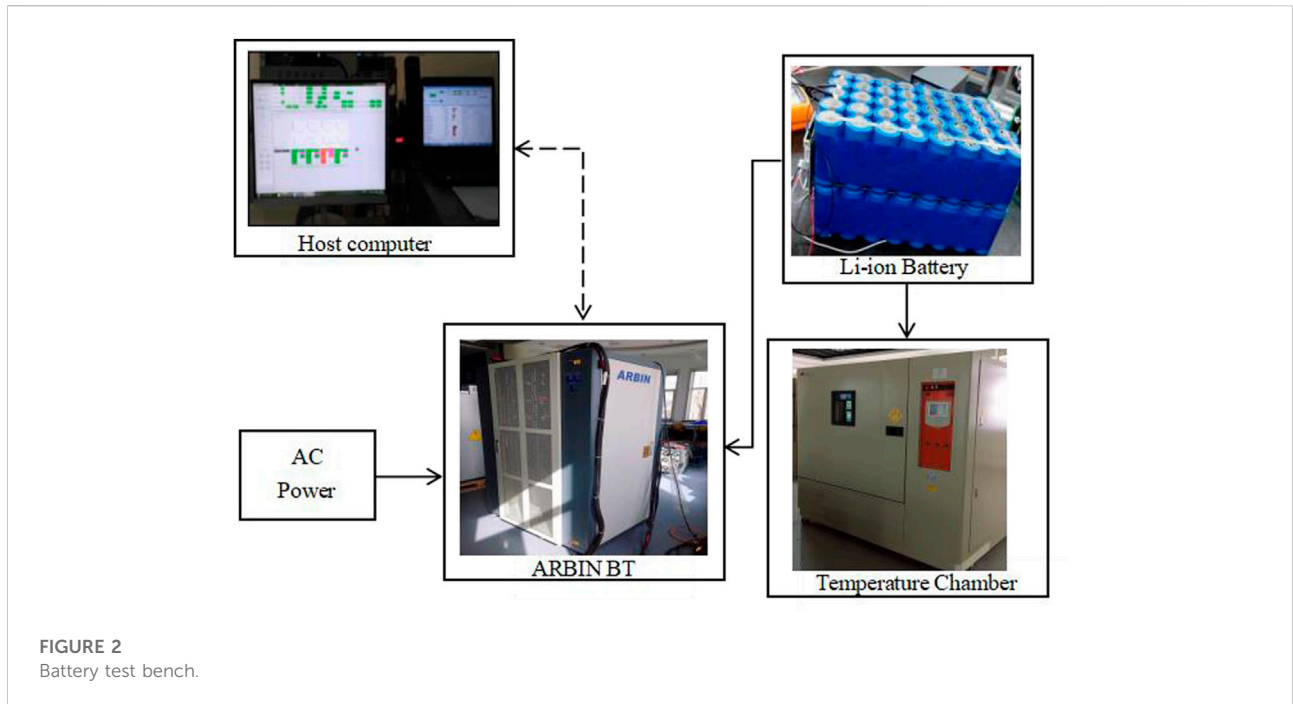

TABLE 2 The identification result of R_1, R_2, C_1, C_2 .

SOC	R_1 (m Ω)	C_1 (F)	R_2 (m Ω)	C_2 (F)
0.1	4.1	118,125.1	6.2	6,305.2
0.2	4.2	120,803.7	5.9	5,762.5
0.3	3.6	143,115.7	5.9	4,974.3
0.4	4.0	121,295.4	7.1	4,396.6
0.5	6.6	62,891.6	7.8	4,990.7
0.6	4.3	104,868.1	7.1	4,088.5
0.8	5.1	81,848.9	10.14	3,576.5
0.9	8.3	44,419.1	14.8	2,588.5
1	17.8	20,480.9	27.7	1,384.3

parameters. The detailed implementation process is shown in Table 1, where denotes the forgetting factor.

2.3 Space state equation of battery model

SOC denotes the state of remaining electrical capacity stored in a battery. It can be expressed as:

$$SOC_t = SOC_{t_0} - \frac{\int Idt}{Q_N} \quad (14)$$

The relationship between SOC and open-circuit voltage of battery can be expressed as:

$$V_{ocv} = k_0 + k_1 \ln(SOC) + k_2 \ln(1 - SOC) + k_3 \frac{1}{SOC} + k_4 SOC \quad (15)$$

Where SOC is the state of charge of the battery. k_0, k_1, k_2, k_3, k_4 are the parameters that needs to be identified. The two-order RC equivalent model of lithium-ion battery is

$$\begin{cases} \dot{x} = A \cdot x + B \cdot I \\ y = C \cdot x + D \cdot I \end{cases} \quad (16)$$

Where

$$\begin{cases} A = \begin{bmatrix} 1 & 0 & 0 & 0 \\ 0 & 1 & 0 & 0 \\ 0 & 0 & \exp(-\Delta t/R_1 C_1) & 0 \\ 0 & 0 & 0 & \exp(-\Delta t/R_2 C_2) \end{bmatrix} \\ B = \begin{bmatrix} \frac{\int dt}{Q_N} \\ 0 \\ R_1(1 - \exp(-T/R_1 C_1)) \\ R_2(1 - \exp(-T/R_2 C_2)) \end{bmatrix} \\ C = \begin{bmatrix} \frac{dV_{oc}}{dSOC} & 0 & -1 & -1 \end{bmatrix} \\ D = -R, \quad x = [SOC \ R \ V_1 \ V_2]^T, \quad y = V_0, \quad x \in R^4 \end{cases} \quad (17)$$

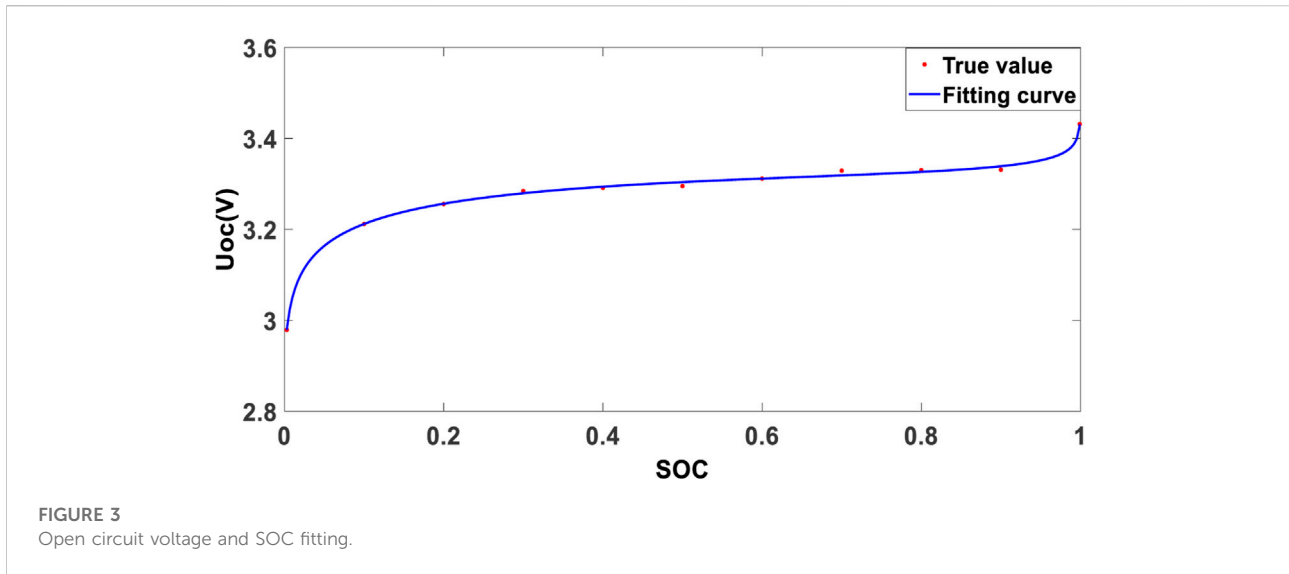

FIGURE 3 Open circuit voltage and SOC fitting.

3 Unscented kalman filter

The basic idea of UKF is Kalman filter and lossless transformation. It can effectively overcome the problems of low accuracy and poor stability of EKF estimation. Because the high-order term does not need to be ignored, the calculation accuracy of nonlinear distribution statistics is high.

When EKF is used to estimate the battery state, the state space model of the battery need to be linearized since the state space model of the battery is nonlinear. The Jacobian matrix will be calculated during the linearization process, which makes the computation complex and reduces the estimation accuracy. The UKF uses the sigma point for nonlinear transformation directly instead of linearizing the battery model, which improves the estimation accuracy.

- Step1. sigma points are set by the mean and variance of the state variables by calculating in accordance with certain rules.
- Step2. sigma points will be operated by the state-space model to get the new sigma point set.
- Step3. the excellent estimate of state variable is obtained by weighting the new set of point.
- Step4. repeat the previous operation process to iterate.

For a nonlinear system, the state and measurement equations with additional noise are:

$$\begin{cases} x_k = f(x_{k-1}, u_k) + \omega_k \\ y_k = g(x_{k-1}) + \vartheta_k \end{cases} \quad (18)$$

Where k is the current time, $f()$ is the nonlinear system state transition equation, $g()$ is the nonlinear measurement equation, the ω_k and the ϑ_k are process noise and measurement

noise respectively. Assumed that the ω_k and the ϑ_k are uncorrelated zero-mean white Gaussian noise, and covariance matrixes are respectively. The specific algorithm of UKF is as follows:

$$\begin{cases} \bar{x} = E(x_0) \\ p_0 = E(x_0 - \bar{x})(x_0 - \bar{x})^T \end{cases} \quad (19)$$

The sigma point is set as follows:

$$x_{k-1,i} = \begin{cases} \bar{x}_{k-1} + \left[\sqrt{(n+\lambda)p_{k-1}} \right]_i, & i = 1, \dots, n \\ \bar{x}_{k-1} - \left[\sqrt{(n+\lambda)p_{k-1}} \right]_i, & i = n+1, \dots, 2n+1 \end{cases} \quad (20)$$

Time update equation is as follows:

$$\begin{cases} x_{k|k-1,i} = f(x_{k-1,i}), & \bar{x}_{k^-} = \sum_{i=0}^{2n} \omega_i^m x_{k|k-1,i} \\ p_{k|k-1} = \sum_{i=0}^{2n} \omega_i^c (x_{k-1,i} - \bar{x}_{k^-})(x_{k-1,i} - \bar{x}_{k^-})^T + Q_k \\ y_{k|k-1,i} = g(x_{k-1,i}), & \bar{y}_{k^-} = \sum_{i=0}^{2n} \omega_i^m [g(x_{k|k-1,i}) + v_{k-1,i}] = \sum_{i=0}^{2n} \omega_i^m y_{k|k-1,i} \end{cases} \quad (21)$$

The measurement update equation is as follows:

$$\begin{cases} p_{\bar{y},k} = \sum_{i=0}^{2n} \omega_i^c (y_{k|k-1,i} - \bar{y}_{k^-})(y_{k|k-1,i} - \bar{y}_{k^-})^T + Q_k \\ p_{\bar{x},y,k} = \sum_{i=0}^{2n} \omega_i^c (x_{k-1,i} - \bar{x}_{k^-})(y_{k|k-1,i} - \bar{y}_{k^-})^T \\ K = p_{\bar{y},k} p_{\bar{x},y,k}, & \bar{x}_k = \bar{x}_{k^-} + K(y_k - \bar{y}_{k^-}), \quad p_{k|k} = p_{k|k-1} - K p_{\bar{y},k} K^T \end{cases} \quad (22)$$

It is seen from the above formulas that as long as the initial conditions and are given, the optimal estimate value of the state

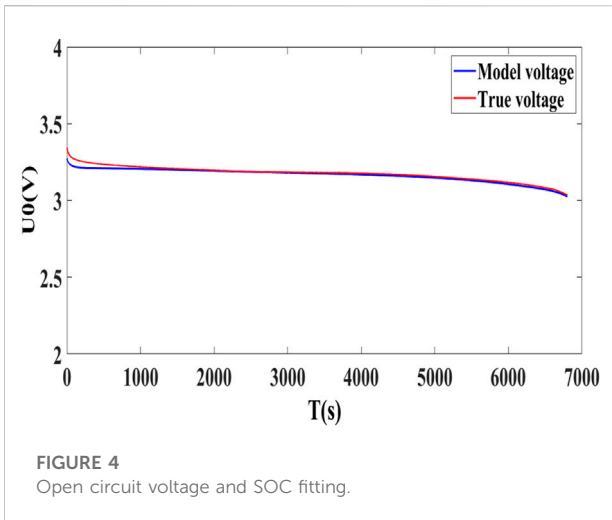

FIGURE 4 Open circuit voltage and SOC fitting.

at time k can be estimated depending on the state value at time $k-1$, the input value and the observed value at time k .

4 Experimental

The test object is LiFePO_4 batteries with the nominal capacity of 6.2 Ah and the nominal voltage of 3.2 V. To verify the accuracy of the two-order model and the effectiveness of battery state estimation

algorithm, a battery test bench has been established, as shown in Figure 2. Constant discharge current is 0.5C. The experimental environment temperature is 25°C. R_1 , C_1 , R_2 and C_2 were identified which is shown in Table 2. And the SOC initial value of the battery is 0.9 while the SOC value is 0.1 when the experiment reached the discharge cut-off condition. Then the SOC and open circuit voltage can be fitted as shown in Figure 3. Battery’s measured terminal voltage and estimated voltage curves are shown in Figure 4. The error is shown in Figure 5, and it can be seen that the maximum error is less than 0.08 V. From the above experimental results, we can see that the battery model is accurate.

In this paper, the SOC is estimated by the EKF and the UKF, which are validated through the experiments under different conditions. Figures 6–9 show that the two algorithms are accurate and reliable to estimate SOC. The maximum errors of two algorithms are less than 4 and 1.4% respectively. It can be seen that the UKF algorithm is more accurate than EKF algorithm on SOC estimation. The UKF algorithm is more stable than the EKF algorithm for the EKF’s error is within 2.5% while the error of UKF is less than 0.5% when the SOC is in the range of 90–20%. During the discharge end when SOC is less than 20%, the errors of these two algorithms are both larger since the battery works in a highly non-linear region. The error of EKF is nearly 4%, while the peak error of UKF is less than 1.4% which is still relatively small. In summary, UKF algorithm is more stable and accurate than EKF algorithm.

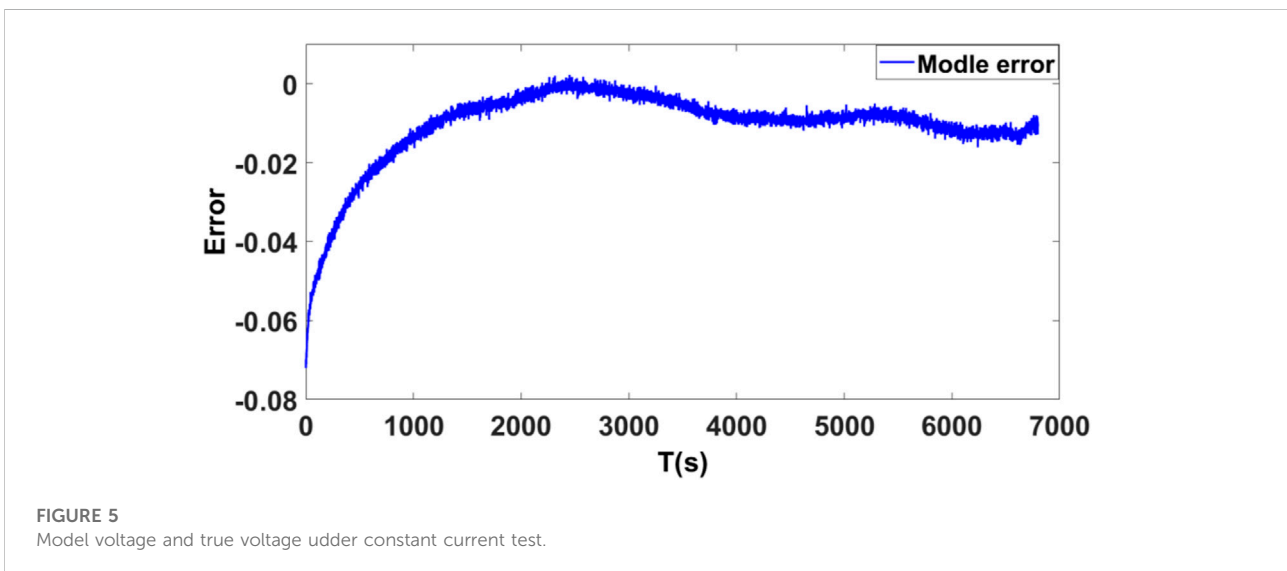

FIGURE 5 Model voltage and true voltage under constant current test.

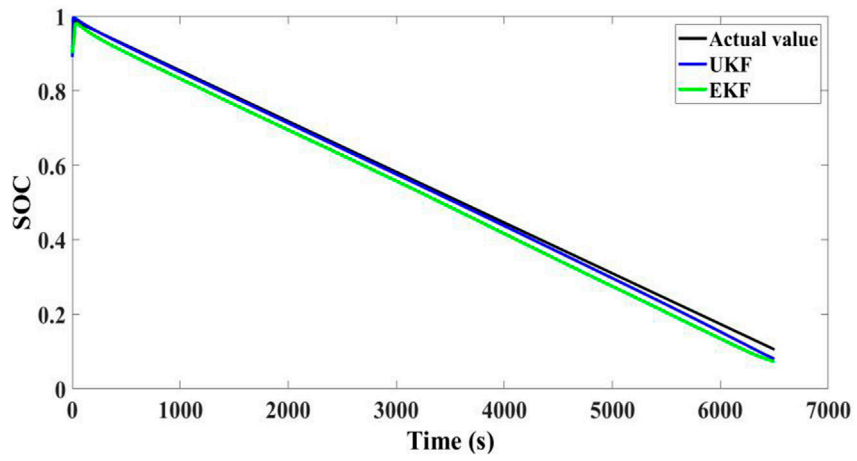

FIGURE 6
SOC estimate results under constant current condition.

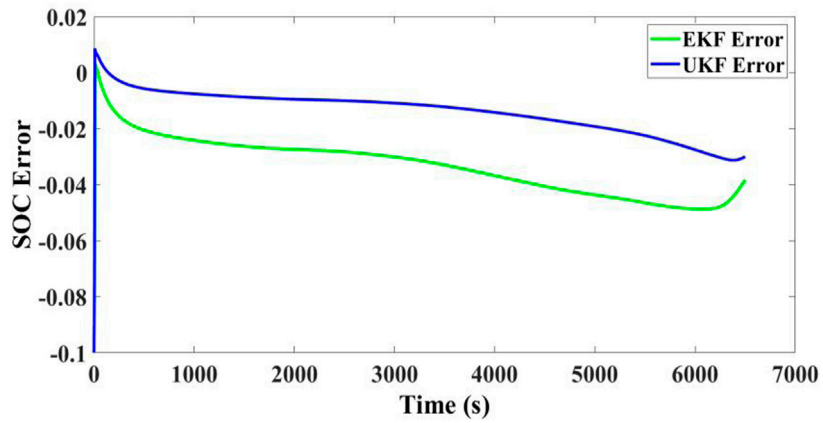

FIGURE 7
Comparison of SOC estimate error under constant current discharge.

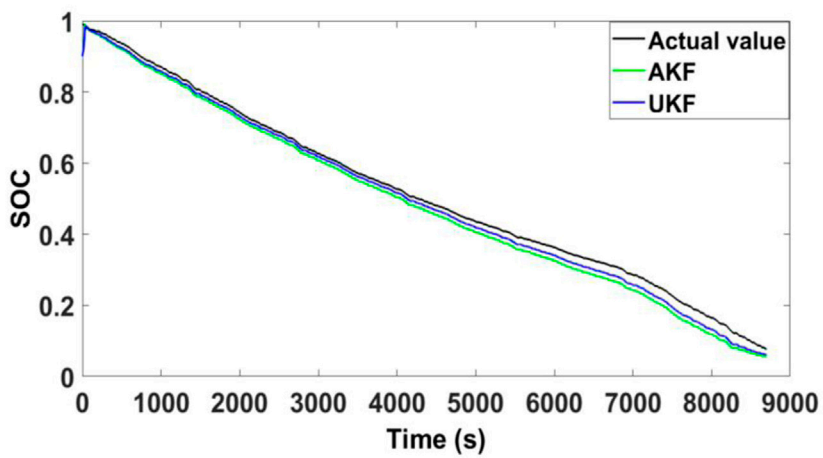
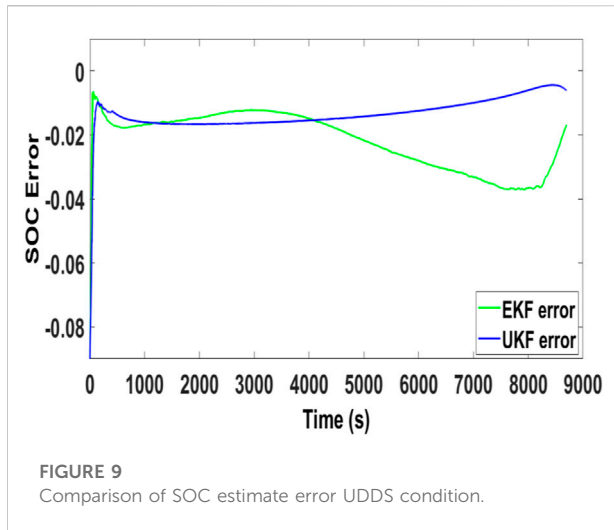

FIGURE 8
SOC estimate results under UDDS condition.



5 Conclusion

As the main power source of electric vehicle, the performance of power battery directly affects the economy, power and reliability of the vehicle. In order to ensure the safe and stable operation of electric vehicles in complex driving environment, it is necessary to effectively manage the power battery system and prolong the battery life. In the complex and changeable environment, the accurate modeling and accurate state estimation of power battery can ensure the safe and reliable operation of battery management system. The equivalent model of power battery has important significance for SOC estimation. By employing the UKF, the battery SOC was estimated using the two-order RC model. However, the modeling is not accurate enough and the battery state can not be accurately estimated in real time. These problems have always been recognized as difficult problems in academic and industrial circles. The UKF is proposed to estimate the SOC in this paper. To verify the performance of the UKF method, experiments were conducted on battery test bench. The obtained results have demonstrated that the UKF algorithm has provided better performance in comparison with the extended Kalman filter.

References

- Chen, X., Lei, H., Xiong, R., Shen, W., and Yang, R. (2019). A novel approach to reconstruct open circuit voltage for state of charge estimation of lithium ion batteries in electric vehicles. *Appl. Energy* 255, 113758. doi:10.1016/j.apenergy.2019.113758
- Cheng, W., and Tinglong, P. A. N. (2020). Prediction for SOC of lithium-ion batteries by estimating the distribution algorithm with LSSVM[J]. *Energy Storage Sci. Technol.* 9 (6), 1948. doi:10.19799/j.cnki.2095-4239.2020.0165
- Feng, F., Teng, S., Liu, K., Xie, J., Xie, Y., Liu, B., et al. (2020). Co-estimation of lithium-ion battery state of charge and state of temperature based on a hybrid electrochemical-thermal-neural-network model. *J. Power Sources* 455, 227935. doi:10.1016/j.jpowsour.2020.227935

Data availability statement

The raw data supporting the conclusions of this article will be made available by the authors, without undue reservation.

Author contributions

Conceptualization, JG and SL; methodology, JG and SL; software, JG and SL; validation, JG and SL; formal analysis, JG and SL; investigation, JG and SL; resources, JG and SL; data curation, JG and SL; writing—original draft preparation, JG and SL; writing—review and editing, JG and SL; visualization, JG and SL; supervision, JG and SL; project administration, SL; funding acquisition, SL and RZ. All authors have read and agreed to the published version of the manuscript.

Funding

This research was funded by the Natural Science Foundation of Shandong Province (Grant number: ZR2020QF064) and the Research Leader Studio Project of Jinan City (Grant number: 2019GXRC062).

Conflict of interest

The authors declare that the research was conducted in the absence of any commercial or financial relationships that could be construed as a potential conflict of interest.

Publisher's note

All claims expressed in this article are solely those of the authors and do not necessarily represent those of their affiliated organizations, or those of the publisher, the editors and the reviewers. Any product that may be evaluated in this article, or claim that may be made by its manufacturer, is not guaranteed or endorsed by the publisher.

- Gao, W., Zheng, Y., Ouyang, M., Li, J., Lai, X., and Hu, X. (2018). Micro-short-circuit diagnosis for series-connected lithium-ion battery packs using mean-difference model. *IEEE Trans. Ind. Electron.* 66 (3), 2132–2142. doi:10.1109/TIE.2018.2838109
- Guo, Y., Yang, Z., Liu, K., Zhang, Y., and Feng, W. (2021). A compact and optimized neural network approach for battery state-of-charge estimation of energy storage system. *Energy* 219, 119529. doi:10.1016/j.energy.2020.119529
- Jiao, M., Wang, D., and Qiu, J. (2020). A GRU-RNN based momentum optimized algorithm for SOC estimation. *J. Power Sources* 459, 228051. doi:10.1016/j.jpowsour.2020.228051

- Kwak, M., Lkhagvasuren, B., Park, J., and You, J. H. (2019). Parameter identification and SOC estimation of a battery under the hysteresis effect. *IEEE Trans. Ind. Electron.* 67 (11), 9758–9767. doi:10.1109/TIE.2019.2956394
- Li, D., Danilov, D. L., Zwikirsch, B., Fichtner, M., Yang, Y., Eichel, R. A., et al. (2017). Modeling the degradation mechanisms of C6/LiFePO4 batteries. *J. power sources* 375, 106–117. doi:10.1016/j.jpowsour.2017.11.049
- Li, W., Cao, D., Jöst, D., Ringbeck, F., Kuipers, M., Frie, F., et al. (2020). Parameter sensitivity analysis of electrochemical model-based battery management systems for lithium-ion batteries. *Appl. Energy* 269, 115104. doi:10.1016/j.apenergy.2020.115104
- Peng, J., Luo, J., He, H., and Lu, B. (2019). An improved state of charge estimation method based on cubature Kalman filter for lithium-ion batteries. *Appl. Energy* 253, 113520. doi:10.1016/j.apenergy.2019.113520
- She, C., Wang, Z., Sun, F., Liu, P., and Zhang, L. (2019). Battery aging assessment for real-world electric buses based on incremental capacity analysis and radial basis function neural network. *IEEE Trans. Ind. Inf.* 16 (5), 3345–3354. doi:10.1109/TII.2019.2951843
- Shen, S., Sadoughi, M., Li, M., Wang, Z., and Hu, C. (2020). Deep convolutional neural networks with ensemble learning and transfer learning for capacity estimation of lithium-ion batteries. *Appl. Energy* 260, 114296. doi:10.1016/j.apenergy.2019.114296
- Shuzhi, Z., Xu, G., and Xiongwen, Z. (2021). A novel one-way transmitted co-estimation framework for capacity and state-of-charge of lithium-ion battery based on double adaptive extended Kalman filters. *J. Energy Storage* 3, 102093. doi:10.1016/j.est.2020.102093
- Singh, K. V., Bansal, H. O., and Singh, D. (2020). Hardware-in-the-loop implementation of ANFIS based adaptive SoC estimation of lithium-ion battery for hybrid vehicle applications. *J. Energy Storage* 27, 101124. doi:10.1016/j.est.2019.101124
- Tran, M. K., Mevawala, A., Panchal, S., Raahemifar, K., Fowler, M., and Fraser, R. (2020). Effect of integrating the hysteresis component to the equivalent circuit model of Lithium-ion battery for dynamic and non-dynamic applications. *J. Energy Storage* 32, 101785. doi:10.1016/j.est.2020.101785
- Wu, L., Liu, K., and Pang, H. (2021). Evaluation and observability analysis of an improved reduced-order electrochemical model for lithium-ion battery. *Electrochimica Acta* 368, 137604. doi:10.1016/j.electacta.2020.137604
- Yang, C., Wang, X., Fang, Q., Dai, H., Cao, Y., and Wei, X. (2020). An online SOC and capacity estimation method for aged lithium-ion battery pack considering cell inconsistency. *J. Energy Storage* 29, 101250. doi:10.1016/j.est.2020.101250
- Yang, F., Li, W., Li, C., and Miao, Q. (2019). State-of-charge estimation of lithium-ion batteries based on gated recurrent neural network. *Energy* 175, 66–75. doi:10.1016/j.energy.2019.03.059
- Zhao, Y., Xu, J., Wang, X., and Mei, X. (2018). The adaptive fading extended kalman filter SOC estimation method for lithium-ion batteries. *Energy Procedia* 145, 357–362. doi:10.1016/j.egypro.2018.04.064
- Zheng, Y., Gao, W., Ouyang, M., Lu, L., Zhou, L., and Han, X. (2018). State-of-charge inconsistency estimation of lithium-ion battery pack using mean-difference model and extended Kalman filter. *J. Power Sources* 383, 50–58. doi:10.1016/j.jpowsour.2018.02.058
- Zhu, J., Darma, M. S. D., Knapp, M., Sorensen, D. R., Heere, M., Fang, Q., et al. (2020). Investigation of lithium-ion battery degradation mechanisms by combining differential voltage analysis and alternating current impedance. *J. Power Sources* 448, 227575. doi:10.1016/j.jpowsour.2019.227575
- Zuo, H., Zhang, B., Huang, Z., Wei, K., Zhu, H., and Tan, J. (2022). Effect analysis on SOC values of the power lithium manganate battery during discharging process and its intelligent estimation. *Energy* 238, 121854. doi:10.1016/j.energy.2021.121854
- Zuo, W., Luo, M., Liu, X., Wu, J., Liu, H., Li, J., et al. (2020). Li-Rich cathodes for rechargeable Li-based batteries: Reaction mechanisms and advanced characterization techniques. *Energy Environ. Sci.* 13, 4450–4497. doi:10.1039/D0EE01694B