



OPEN ACCESS

EDITED BY
Tianguang Lu,
Shandong University, China

REVIEWED BY
Tao Chen,
Southeast University, China
Licheng Wang,
Zhejiang University of Technology,
China

*CORRESPONDENCE
DianSheng Luo,
lhx20070322@hnu.edu.cn

SPECIALTY SECTION
This article was submitted to Smart
Grids,
a section of the journal
Frontiers in Energy Research

RECEIVED 20 June 2022
ACCEPTED 15 August 2022
PUBLISHED 19 September 2022

CITATION
Luo D, Xi R, Che L and He H (2022),
Health condition assessment of
transformers based on cross message
passing graph neural networks.
Front. Energy Res. 10:973736.
doi: 10.3389/fenrg.2022.973736

COPYRIGHT
© 2022 Luo, Xi, Che and He. This is an
open-access article distributed under
the terms of the [Creative Commons
Attribution License \(CC BY\)](https://creativecommons.org/licenses/by/4.0/). The use,
distribution or reproduction in other
forums is permitted, provided the
original author(s) and the copyright
owner(s) are credited and that the
original publication in this journal is
cited, in accordance with accepted
academic practice. No use, distribution
or reproduction is permitted which does
not comply with these terms.

Health condition assessment of transformers based on cross message passing graph neural networks

DianSheng Luo^{1*}, RuiYao Xi¹, LiXuan Che² and HongYing He¹

¹College of Electrical and Information Engineering, Hunan University, Changsha, China, ²Weifang Vocational College, Weifang, China

A method is proposed to assess the health condition of transformers based on cross message passing graph neural networks (CMPGNNs) in this paper. In order to improve the accuracy of transformer health condition assessment, multiple indicators and their strong correlation are taken into account. The evaluation indicators are divided into four comprehensive state categories, and each category has several indicators. First, the correlation between indicators of a state category is extracted by the health index method and the importance of criteria is analyzed through the inter-criteria correlation (CRITIC) method, and the health index of comprehensive indicators is obtained. Then, a diagram of comprehensive indicators is constructed, and the correlation between indicators of different state categories is extracted. Finally, CMPGNN is constructed to achieve the health assessment. The experimental results show that the proposed method can improve the accuracy of transformer health condition assessment.

KEYWORDS

power transformer, health condition assessment, health index, cross message passing graph neural network, correlation of indicators

1 Introduction

A power transformer is one of the most important parts of the power system (Xie et al., 2020), and the health of a power transformer plays a vital role in the safe operation of power grids and the development of national economy (Wang et al., 2022). Accurate health condition assessment helps detect potential faults and reduce maintenance costs by 20–50% (Sun et al., 2022).

A power transformer is a large system with a complex structure. The selection of indicators is important for the assessment of the transformer health condition. Zhang et al., 2021 select dissolved gases in oil as the evaluation indicator. With the operation of the transformer, the aging of the pressboard will produce furfural. Therefore, furfural content can effectively reflect the aging of insulation (Lin et al., 2019). In Benhmed et al., 2018, indicators of dissolved gases and oil tests are selected to construct an evaluation system. However, in the above methods, only indicators of preventive tests are considered,

and indicators of other information, such as the basic information, operating information, and fault maintenance information, are ignored.

At present, the health condition assessment methods include not only single algorithms such as an expert system (Purkait and Chakravorti, 2002), fuzzy theory (Abu-Elanien et al., 2012; Arshad et al., 2014), the Bayesian network (Quan et al., 2013), and the artificial neural network (Pengju and Birtwhistle, 2001) but also the collaborative algorithm of multiple methods (Liao et al., 2011). The mapping between seven dissolved gases and the transformer health condition is established by linear models and nonlinear models (Zeinoddini-Meymand et al., 2021). In reference Islam et al., 2018, the general regression neural network (GRNN) is used to quantify the operating state of each component of the transformer. In reference Ashkezari et al., 2013, a fuzzy support vector machine (FSVM) is constructed to predict the health condition of the transformer insulation system by using the indicators of dissolved gases and oil tests. In fact, there are correlations between indicators. If correlations are not taken into account, the accuracy of evaluation results will be reduced.

Aiming at the problems existing in the transformer health condition assessment method, a method is proposed to assess the health condition of the transformer based on cross message passing graph neural networks (CMPGNNs) in this paper. In this method, the evaluation system of the transformer is established by selecting the indicators of various state information. The health index method and criteria importance through the inter-criteria correlation (CRITIC) method are used to consider the correlation between indicators of a state category. Aiming at the correlation between indicators of different state categories, a diagram of comprehensive indicators is established, and a graph neural network (GNN) based on the cross message passing mechanism is constructed to mine the relationship between indicators and achieve health condition assessment. The experimental results show that it is beneficial to evaluate the health condition of the transformer by using the indicators of multiple state information. The correlation between indicators is fully considered by utilizing CRITIC and CMPGNN, which makes the evaluation results more accurate. In addition, GNN based on the cross message passing mechanism can improve the accuracy of the graph classification task.

2 Health index of comprehensive indicators

2.1 The construction of the transformer evaluation system

Load rate and operating environment are two important factors affecting the insulation performance of power transformers (Muthanna et al., 2006). A preventive test is an effective method to detect the aging of the transformer. In

addition, the number of transformer faults is directly related to the health condition (En-Wen and Bin, 2014). In order to consider the state information as much as possible, indicators of four comprehensive state categories, including basic operational information, dissolved gas analysis, oil tests, and electrical tests, are selected to build an evaluation system, as shown in Figure 1A. Each state category includes several sub-state indicators, which are regarded as the low-level indicators.

2.2 Health index of basic operational information

Health index (HI) is the representation of transformer aging degree, and its value ranges from 0 to 10. The larger the health index, the worse the health condition of the transformer.

Four low-level indicators including operating time, designed life, load rate, and operating environment are used to obtain the health index of basic operational information. The health index of basic operational information is expressed as

$$HI_1 = HI_0 * e^{B * (T_2 - T_1)} \quad (1)$$

where HI_0 is the initial health index of the transformer, which is generally taken as 0.5. $(T_2 - T_1)$ is the operating time. B is the aging coefficient, which can be expressed as

$$B = \frac{\ln HI_t - \ln HI_0}{T_d} * f_L * f_E \quad (2)$$

where HI_t is the health index corresponding to the time when the transformer has a high probability of failure, which is generally taken as 7. T_d is the designed life. f_L and f_E are the correction coefficients of load and environment, respectively. Their values are shown in Table 1.

2.3 Preprocessing of low-level indicators of the preventive test

The preventive test includes dissolved gas analysis, oil tests, and electrical tests. The low-level indicators of the preventive test are divided into positive and negative indicators. The positive indicator is the indicator that the larger the value, the better the health condition of the transformer, such as breakdown voltage. The negative indicator is the indicator that the larger the value, the worse the health condition of the transformer, such as water content. Positive indicators and negative indicators are preprocessed by Eq. 3 and Eq. 4, respectively.

$$y = \begin{cases} 10 & 0 \leq x \leq a \\ 5 - 5 \sin \left[\frac{\pi}{b-a} * \left(x - \frac{a+b}{2} \right) \right] & a \leq x \leq b \\ 0 & x > b \end{cases} \quad (3)$$

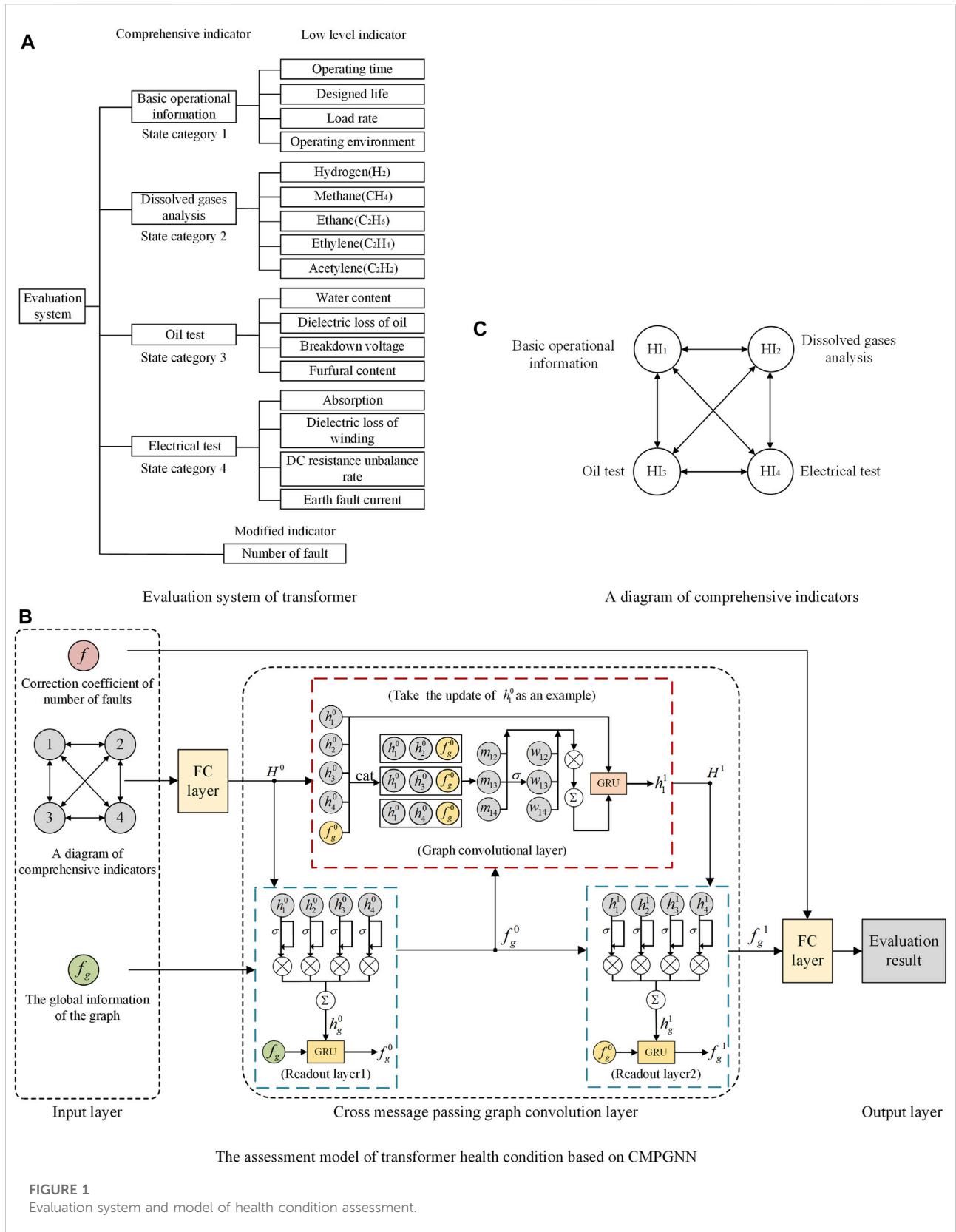

TABLE 1 Correction coefficient for load, environment, and number of faults.

Load rate (%)	f_L	Environment grade	f_E	Number of faults	Correction coefficient of number of faults
[0–40)	1	0	1	0–1	0.96
[40–60)	1.05	1	1	2–4	1.04
[60–70)	1.1	2	1.05	5–10	1.2
[70–80)	1.25	3	1.15	>10	1.4
[80–150)	1.6	4	1.3	-	-

TABLE.2 Thresholds and pretreatment methods of low-level indicators.

Low-level indicator	a	b	Formula of pretreatment
H ₂ (μL/L)	10	150	Eq. 3
CH ₄ (μL/L)	0	60	Eq. 3
C ₂ H ₆ (μL/L)	0	40	Eq. 3
C ₂ H ₄ (μL/L)	0	70	Eq. 3
C ₂ H ₂ (μL/L)	0	5	Eq. 3
Water content (mg/L)	20	35	Eq. 3
Dielectric loss of oil (%)	0	4	Eq. 3
Breakdown voltage (kV)	35	50	Eq. 4
Furfural content (mg/L)	0	4	Eq. 3
Absorption	1.3	2	Eq. 4
Dielectric loss of winding (%)	0	0.8	Eq. 3
DC resistance unbalance rate (%)	0	2	Eq. 3
Earth fault current (mA)	0	100	Eq. 3

$$y = \begin{cases} 0 & 0 \leq x \leq a \\ 5 + 5 \sin \left[\frac{\pi}{b-a} * \left(x - \frac{a+b}{2} \right) \right] & a \leq x \leq b \\ 10 & x > b \end{cases} \quad (4)$$

where a and b are thresholds for indicators. x is the measured value. y is the preprocessed value, which means the health index of each low-level indicator. In this paper, 110 kV power transformer is taken as an example. The thresholds and pretreatment methods of low-level indicators are shown in Table 2.

2.4 Weight of low-level indicators of the preventive test

The CRITIC method uses the contrast intensity and conflict of the samples to obtain the weights of indicators. Contrast intensity refers to the volatility of the value of an indicator in different samples. The greater the volatility, the stronger the contrast intensity and the higher the weight of the indicator.

Conflict refers to the correlation between different indicators. The greater the correlation, the less the conflict and the lower the weight of the indicator. In this paper, the CRITIC method is used to obtain the correlation between indicators of a state category and assign weights to each indicator. With n samples and m evaluation indicators, the state evaluation matrix is

$$X = \begin{bmatrix} x_{11} & x_{12} & \cdots & x_{1j} & \cdots & x_{1m} \\ x_{21} & x_{22} & \cdots & x_{2j} & \cdots & x_{2m} \\ \vdots & \vdots & \vdots & \vdots & \cdots & \vdots \\ x_{i1} & x_{i2} & \cdots & x_{ij} & \cdots & x_{im} \\ \vdots & \vdots & \vdots & \vdots & \cdots & \vdots \\ x_{n1} & x_{n2} & \cdots & x_{nj} & \cdots & x_{nm} \end{bmatrix} \quad (5)$$

where x_{ij} is the value of the j th indicator of the i th sample. Positive indicators and negative indicators are normalized by Eq. 6 and Eq. 7, respectively.

$$x'_{ij} = \frac{x_{ij} - \min_{1 \leq i \leq n} \{x_{ij}\}}{\max_{1 \leq i \leq n} \{x_{ij}\} - \min_{1 \leq i \leq n} \{x_{ij}\}} \quad (6)$$

$$x'_{ij} = \frac{\max_{1 \leq i \leq n} \{x_{ij}\} - x_{ij}}{\max_{1 \leq i \leq n} \{x_{ij}\} - \min_{1 \leq i \leq n} \{x_{ij}\}} \quad (7)$$

In this paper, the standard deviation is used to measure the contrast intensity of the low-level indicators, which can be expressed as follows:

$$\bar{x}_j = \frac{1}{n} \sum_{i=1}^n x'_{ij} \quad (8)$$

$$P_j = \sqrt{\frac{\sum_{i=1}^n (x'_{ij} - \bar{x}_j)^2}{n}} \quad (9)$$

where \bar{x}_j represents the average value of indicator j . P_j is the standard deviation of indicator j . In this paper, the Spearman correlation coefficient is used to measure the conflict between the low-level indicators, which is expressed as follows:

$$d_i = z_{i(s)} - z_{i(j)} \quad (10)$$

$$r_{sj} = 1 - \frac{6 * \sum_{i=1}^n d_i^2}{n * (n^2 - 1)} \quad (s, j \in m) \quad (11)$$

where $z_{i(s)}$ and $z_{i(j)}$ represent the new index of the i th sample after the sample sequences of indicator s and indicator j are, respectively, arranged in descending order. d_i represents the difference of the new index. r_{sj} represents the correlation coefficient between indicator s and indicator j , and $r_{sj} = r_{js}$.

The conflict of indicator j is expressed as follows:

$$Q_j = \sum_{s=1}^m (1 - r_{sj}) \quad (12)$$

Therefore, the information provided by indicator j is expressed as follows:

$$T_j = P_j * Q_j \quad (13)$$

Then the weight of indicator j is expressed as follows:

$$w_j = T_j / \sum_{j=1}^m T_j \quad (14)$$

2.5 Health index of dissolved gas analysis, oil tests, and electrical tests

The health index of dissolved gas analysis, oil tests, and electrical tests can be expressed as follows:

$$HI_i = \sum_{j=1}^o y_j w_j \quad (15)$$

where i is equal to 2, 3, and 4, and the corresponding HI_i is the health index of dissolved gas analysis, oil tests, and electrical tests, respectively. o is the number of low-level indicators. o is equal to 5, 4, and 4.

3 Assessment of the transformer health condition based on cross message passing graph neural networks

The assessment model of the transformer health condition based on CMPGNN is shown in Figure 1B. According to the figure, the model includes an input layer, a cross message passing graph convolution layer, and an output layer.

3.1 Input and output of the model

The input layer consists of three parts, namely, the correction coefficient of the number of faults, a diagram of comprehensive indicators, and the global information of the graph. The correction coefficient of the number of faults is determined by the number of faults, as shown in Table 1.

In order to mine the correlation between indicators of different state categories, this paper constructs a diagram of comprehensive indicators as shown in Figure 1C. Each node on the graph represents a comprehensive indicator. The characteristic information of the node is the health index of the comprehensive indicator. The edges between nodes represent the possible correlations between comprehensive indicators.

When mining the correlation between indicators and updating the characteristic information of each indicator, not only the local information but also the global information of the graph should be taken into account. The global information of the graph is the centralized representation of the diagram of comprehensive indicators, which contains the important information of each node and the correlation between nodes.

Transformer health condition types include excellent, good, average, poor, and serious. Therefore, these five health conditions are selected as the output of the model. In addition, the health level for each health condition is set to 0, 1, 2, 3, and 4, respectively.

3.2 Working principle of the cross message passing graph convolution layer

The message passing mechanism is the framework followed by the GNN, including the message passing stage and readout stage. It completes the learning task on the graph according to the correlation between nodes on the graph. The GNN based on the traditional message passing mechanism only performs the readout operation after the message passing stage, and the dynamic features of the graph are ignored during the running time step. In addition, in the process of message generation in the message passing stage, only the information of its own node and neighbor node is considered, and the global information of the

graph is not considered. To solve the above problems, a cross message passing mechanism is proposed.

The readout layer is used to realize the readout operation and complete the extraction of the global information of the graph. The sigmoid function is introduced to retain important information of each node and remove redundant information. Then, the aggregation of important information of all nodes on the graph h_g^t can be expressed as follows:

$$h_g^t = \sum_{i \in G} (h_i^t \odot \text{sigmoid}(v_1(h_i^t))) \quad (16)$$

where $v_1(\cdot)$ is a linear function. t is the running time step. h_i^t is the information of node i in time step t . G is the set of all nodes on the graph.

The gated recurrent neural network (GRU) includes a reset gate and update gate. The reset gate is used to forget part of the information from the previous time and generate candidate information by combining the selected important historical information with the new input information. The update gate is used to retain part of the information of the previous time and generate the information of the current time by combining the retained historical information with the candidate information. Compared with feed forward neural networks, GRU has memory functions. In addition, compared with long short-term memory networks, GRU has fewer parameters, which can reduce the risk of overfitting.

Therefore, GRU is used to synthesize the global information of the graph at the previous time f_g^{t-1} and aggregation of important information of all nodes h_g^t and update the global information of the graph at current time f_g^t in this paper,

$$f_g^t = \text{GRU}(f_g^{t-1}, h_g^t) \quad (17)$$

The graph convolution layer is used to realize the message passing stage, which completes message generation, message aggregation, and node embedding update. First, a nonlinear neural network is constructed to generate messages between nodes with correlation, and its principle is formulated as

$$e_{ij}^{t+1} = u(v_2(h_i^t \parallel h_j^t \parallel f_g^t)) \quad (18)$$

where $v_2(\cdot)$ is a linear function. \parallel is the concatenation operation, which concatenates the i node information, the j node information, and the global information of the graph with time step t . $u(\cdot)$ is a nonlinear activation function. By constructing the nonlinear relationship, the message generated from node j to node i in time step $(t+1)$ is obtained.

In the message aggregation, in order to avoid assigning the same weight to each neighbor node, the sigmoid function is used to assign different passing coefficients for the generated messages. By multiplying the corresponding coefficients with the generated messages and adding them, the aggregation of

messages generated by the neighbor node can be obtained, which can be expressed by the formula

$$u_i^{t+1} = \sum_{j \in N(i)} (e_{ij}^{t+1} \odot \text{sigmoid}(v_3(e_{ij}^{t+1}))) \quad (19)$$

where $v_3(\cdot)$ is a linear function. $N(i)$ is the set of neighbor nodes of node i .

In the updating of the node embedding, not only the aggregation of messages generated by neighbor nodes is used but also the previous information of its own node is used. GRU can selectively retain and forget some historical information and realize update, which is expressed as

$$h_i^{t+1} = \text{GRU}(h_i^t, u_i^{t+1}) \quad (20)$$

Finally, the health condition of the transformer is obtained by a full connection layer which is constructed by using the output of the cross message graph convolution layer and the correction coefficient of the number of the faults.

4 Experiment

4.1 Experimental process

Based on Python language, the model is built on the Spyder platform. The virtual environment is Python 3.7 built by Anaconda.

The training set is used to train the transformer health condition assessment model based on CMPGNN. Figure 2A shows the curve of training loss with the number of iterations. As can be seen from the figure, when the number of trainings reaches 100 times, the loss curve changes slowly and tends to be stable.

Figure 2B is the confusion matrix of the test set. It can be seen from the figure that the model has better performance for transformer health condition evaluation, and there are fewer misjudgments. In addition, the evaluation accuracy of the proposed method in this test set is 95%.

4.2 The influence of the selection of indicators on health condition assessment results

At present, most evaluation methods of the transformer health condition only use the indicators of preventive tests. Therefore, the health condition assessment results using the indicators selected in this paper are compared with those using only indicators of preventive tests. The confusion matrix for the test set using indicators of the preventive test is shown in Figure 2C.

As a large system, there are many factors affecting the health condition of the power transformer, and the preventive

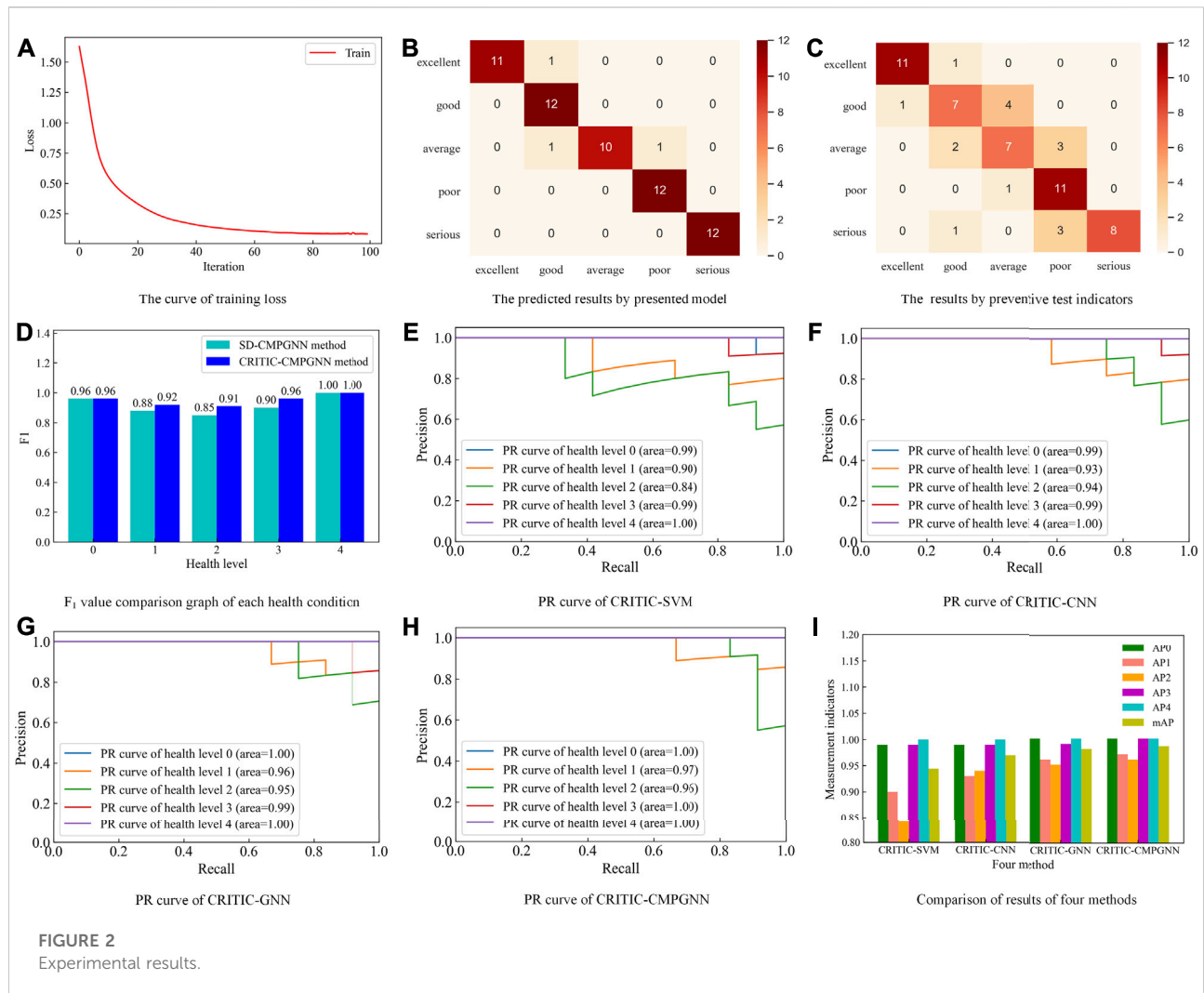

FIGURE 2
Experimental results.

test indicators are only a part of them. Therefore, the health condition of the transformer cannot be accurately obtained by using only the indicators of the preventive test, as shown in Figure 2C.

4.3 The influence of correlation between indicators of a state category on results

The standard deviation method (SD) uses the standard deviation to obtain the sample volatility and assigns weights to each indicator. Compared with the CRITIC method, this method lacks consideration of the correlation between indicators. In this paper, the results of SD-CMPGNN and

CRITIC-CMPGNN methods are compared, as shown in Figure 2D.

As can be seen from the figure, the F1 values obtained by using CRITIC-CMPGNN are 0.04, 0.06, and 0.06 higher than those obtained by SD-CMPGNN when the health condition is “good”, “average”, and “poor”, respectively. This is due to the duplication of information between the low-level indicators. In the SD method, the correlation between indicators is ignored, resulting in more redundant information and less important information provided to comprehensive indicators, thus affecting the accuracy of evaluation results. Therefore, considering the correlation between indicators of a state category can improve the accuracy of results.

4.4 The influence of correlation between indicators of different state categories on results

Figures 2E–H are PR curves of the health condition assessment method based on CRITIC-SVM, CRITIC-CNN, CRITIC-GNN, and CRITIC-CMPGNN, respectively.

The results of the four methods are also shown in Figure 2I. Here, AP_i is the area under the PR curve for the i th health condition. mAP is the average of AP for five health conditions. The larger the value of the above indicators, the better the effect of the model. According to the figure, the effect of CRITIC-SVM is the worst, and the effect of CRITIC-CNN is better than that of CRITIC-SVM. This is due to the inherent shortcomings of SVM in solving multiple classification problems, while CNN has good feature extraction ability. Compared with CRITIC-CNN, the effects of CRITIC-CMPGNN and CRITIC-GNN are improved. This is because CMPGNN and GNN can effectively extract the spatial features of the topology and deeply mine the correlation features of the topology. Therefore, considering the correlation between indicators of different state categories can improve the accuracy of results. In addition, the effect of CRITIC-CMPGNN is better than that of CRITIC-GNN, which indicates that GNN based on the cross message passing mechanism can improve the accuracy.

5 Conclusion

In order to improve the accuracy of transformer health condition assessment, multiple indicators and their strong correlation are taken into account in this paper. CMPGNN is designed to achieve higher accuracy. The conclusions of this paper are as follows:

- (1) The accuracy of the result is improved by considering the indicators of multiple state information.
- (2) The accuracy of the result is improved by using CRITIC. This is because the correlation between low-level indicators is taken into account, resulting in less redundant information and more important information for comprehensive indicators.
- (3) The accuracy of the result is improved by using CMPGNN. This is because the correlation between the comprehensive indicators is deeply excavated.

References

- Abu-Elanien, A. E. B., Salama, M. M. A., and Ibrahim, M. (2012). Calculation of a health index for oil-immersed transformers rated under 69 kV using fuzzy logic. *IEEE Trans. Power Deliv.* 27, 2029–2036. doi:10.1109/TPWRD.2012.2205165
- Arshad, M., Islam, S. M., and Khaliq, A. (2014). Fuzzy logic approach in power transformers management and decision making. *IEEE Trans. Dielectr. Electr. Insul.* 21, 2343–2354. doi:10.1109/TDEI.2014.003859

- (4) In the cross message passing mechanism of CMPGNN, the global information of the graph at the previous time is taken into account in subsequent node updates and global information updates of the graph. This is beneficial to improve the accuracy of evaluation results.

Data availability statement

The original contributions presented in the study are included in the article/supplementary material; further inquiries can be directed to the corresponding author.

Author contributions

LD: conceptualization, methodology, validation, writing—review. XR: gathering data, debug programs, writing—original draft. CL: supervision, writing—revise. HH: methodology, supervision, writing—revise and editing.

Funding

This work is supported by the National Key Research and Development Plan, China, 2017, under Grant 2017YFB0903403.

Conflict of interest

The authors declare that the research was conducted in the absence of any commercial or financial relationships that could be construed as a potential conflict of interest.

Publisher's note

All claims expressed in this article are solely those of the authors and do not necessarily represent those of their affiliated organizations or those of the publisher, the editors, and the reviewers. Any product that may be evaluated in this article or claim that may be made by its manufacturer is not guaranteed or endorsed by the publisher.

- Ashkezari, A. D., Ma, H., Saha, T. K., and Ekanayake, C. (2013). Application of fuzzy support vector machine for determining the health index of the insulation system of in-service power transformers. *IEEE Trans. Dielectr. Electr. Insul.* 20, 965–973. doi:10.1109/TDEL.2013.6518966

- Benhmed, K., Mooman, A., Younes, A., Shaban, K., and El-Hag, A. (2018). Feature selection for effective health index diagnoses of power transformers. *IEEE Trans. Power Deliv.* 33, 3223–3226. doi:10.1109/TPWRD.2017.2762920

- En-Wen, L., and Bin, S. (2014). Transformer health status evaluation model based on multi-feature factors. *2014 Int. Conf. Power Syst. Technol.* 20-22, 1417–1422. doi:10.1109/POWERCON.2014.6993723
- Islam, M., Lee, G., Hettiwatte, S. N., and Williams, K. (2018). Calculating a health index for power transformers using a subsystem-based GRNN approach. *IEEE Trans. Power Deliv.* 33, 1903–1912. doi:10.1109/TPWRD.2017.2770166
- Liao, R., Zheng, H., Grzybowski, S., Yang, L., Zhang, Y., and Liao, Y. (2011). An integrated decision-making model for condition assessment of power transformers using fuzzy approach and evidential reasoning. *IEEE Trans. Power Deliv.* 26, 1111–1118. doi:10.1109/TPWRD.2010.2096482
- Lin, Y., Wei, C., Tao, F., and Li, J. (2019). Aging assessment of oil-paper insulation of power equipment with furfural analysis based on furfural generation and partitioning. *IEEE Trans. Power Deliv.* 34, 1626–1633. doi:10.1109/TPWRD.2019.2916254
- Muthanna, K. T., Sarkar, A., Das, K., and Waldner, K. (2006). Transformer insulation life assessment. *IEEE Trans. Power Deliv.* 21, 150–156. doi:10.1109/TPWRD.2005.855474
- Pengju, K., and Birtwhistle, D. (2001). Condition assessment of power transformer on-load tap-changers using wavelet analysis. *IEEE Trans. Power Deliv.* 16, 394–400. doi:10.1109/61.924817
- Purkait, P., and Chakravorti, S. (2002). Time and frequency domain analyses based expert system for impulse fault diagnosis in transformers. *IEEE Trans. Dielectr. Electr. Insul.* 9, 433–445. doi:10.1109/TDEI.2002.1007708
- Quan, J., Ruan, L., Xie, Z., Li, X., and Lin, X. (2013). The application of Bayesian network theory in transformer condition assessment. *IEEE PES Asia-Pacific Power Energy Eng. Conf (Hong Kong, China: APPEEC)*, 8–11, 1–4. doi:10.1109/APPEEC.2013.6837161
- Sun, C., Zhou, Z., Zhang, Y., Jia, Z., Huang, J., and Huang, C. (2022). A dissolved gas assessment model for power transformers according to weighted association rule mining. *Front. Energy Res.* 10. doi:10.3389/fenrg.2022.879869
- Wang, J., Zhang, X., Zhang, F., Wan, J., Kou, L., and Ke, W. (2022). Review on evolution of intelligent algorithms for transformer condition assessment. *Front. Energy Res.* 10. doi:10.3389/fenrg.2022.904109
- Xie, B., Zhao, D., and Hong, T. (2020). Transformer monitoring and protection in dynamic power systems – a review. *Front. Energy Res.* 8. doi:10.3389/fenrg.2020.00150
- Zeinoddini-Meymand, H., Kamel, S., and Khan, B. (2021). An efficient approach with application of linear and nonlinear models for evaluation of power transformer health index. *IEEE Access* 9, 150172–150186. doi:10.1109/ACCESS.2021.3124845
- Zhang, P., Qi, B., Shao, M., Li, C., Rong, Z., Chen, J., et al. (2021). Optimal data selection rule mining for transformer condition assessment. *IEEE Access* 9, 156962–156972. doi:10.1109/ACCESS.2021.3126763