



Research on Multi-Mode Operation and Coordinated Control Strategy of Grid-Connected Photovoltaic/Biogas/Energy-Storage System for Rural Ecological Breeding

Xinhe Zhang¹, Guixiong He¹, Junjie Xiong², Wei He² and Changlin Xiao^{1*}

¹China Electric Power Research Institute Co., Ltd., Beijing, China, ²Electric Power Research Institute of State Grid Jiangxi Electric Power Co., Ltd., Nanchang, China

OPEN ACCESS

Edited by:

Liansong Xiong,
Nanjing Institute of Technology (NJIT),
China

Reviewed by:

Yongbin Wu,
Southeast University, China
Zheng Lan,
Hunan University of Technology,
China
Rongwu Zhu,
Harbin Institute of Technology, China

*Correspondence:

Changlin Xiao
xcl719@qq.com

Specialty section:

This article was submitted to
Process and Energy Systems
Engineering,
a section of the journal
Frontiers in Energy Research

Received: 15 April 2022

Accepted: 12 May 2022

Published: 03 June 2022

Citation:

Zhang X, He G, Xiong J, He W and
Xiao C (2022) Research on Multi-Mode
Operation and Coordinated Control
Strategy of Grid-Connected
Photovoltaic/Biogas/Energy-Storage
System for Rural Ecological Breeding.
Front. Energy Res. 10:921297.
doi: 10.3389/fenrg.2022.921297

Driven by the rural revitalization strategy and the carbon neutrality goals, the grid-connected photovoltaic/biogas/energy-storage (PV/biogas/ES) system is increasingly widely used in rural China. In this paper, a coordinated operation and control strategy of grid-connected PV/biogas/ES system for rural ecological breeding is proposed. Biogas, ES, and controllable load can adjust their operation state based on meeting constraint conditions to prevent overload from affecting the distribution transformer service life. The line voltage and load can adjust the ES control strategy. The peak shaving and valley filling can be realized through orderly charge/discharge control, in normal operation. Based on virtual synchronous generator (VSG) control, the ES has a certain frequency modulation ability. Meanwhile, overcharge, and over discharge can be avoided by detecting the state of charge (SOC) and adjusting the output power. When the line voltage drops suddenly, VSG can be switched to reactive power compensation mode. The battery energy storage system (BESS) and grid-connected inverter constitute a STATCOM/BESS, which can provide continuous reactive current to the grid to raise the line voltage and improve the system reliability. The effectiveness of the proposed strategy is verified by MATLAB/Simulink simulation.

Keywords: ecological breeding, PV/biogas/ES system, overload prevention of distribution transformer, virtual synchronous machine, STATCOM/BESS

INTRODUCTION

Recently, due to the low-cost and high-revenue characteristics of the breeding industry and the support of relevant policies, the quantities, and scales of rural livestock farms are increasing rapidly (Sayed et al., 2020). However, the breeding industry helps farmers grow their income, and brings environmental problems such as soil, water, and air pollution, which hinders the sustainable development of rural economy and society (Mottet and Tempio, 2017). Using livestock manure to produce biogas for generation can effectively reduce pollution and fossil energy consumption and has been widely used on farms (Scarlat et al., 2018). Driven by the reform trend of the world energy industry, many PV/biogas/ES systems are connected to the grid, which has a broad application prospect in rural ecological breeding. Studying the energy management strategy and control strategy of grid-connected PV/biogas/ES system are significance (Colmenar-Santos et al., 2015; Deng et al., 2022).

The control strategy of PV/biogas/ES combined system for rural ecological breeding needs to consider two aspects, including the operation strategy in different conditions and the coordinated control strategy of each component (Bär et al., 2020; Li et al., 2022). Scholars from various countries have conducted studies on the above-mentioned aspects. In terms of the operation strategy of the hybrid generation system, literature (Al-Masri et al., 2022) introduces a power management method for the PV/biogas hybrid system. However, it does not consider the application of the ES in the system. Literature (Liu et al., 2019) designs a power allocation method for the AC/DC hybrid microgrid, which smooths renewable energy and load power fluctuation by formulating the DC side ES operation strategy. However, applying to a small rural capacity AC grid-connected system would be difficult. Literature (Vivas et al., 2017; Bhattacharjee et al., 2021) introduces the energy management strategy of a hybrid renewable energy grid-connected system, which switches the energy supply mode according to the changes in operating conditions to maintain the balance between supply and demand. Yet, it only focuses on the strategy in normal operation and does not explicitly consider the energy management strategy in abnormal conditions such as distribution transformer overload and grid voltage drop.

Regarding the grid-connected coordinated control strategy of renewable energy and ES hybrid system, literature (Gai et al., 2019; Merahi et al., 2021) introduce the control modes of the distributed generation and ES in the hybrid energy supply and consumption system. Among them, the AC/DC converter adopts P/Q control during the grid-connected operation and V/F control during island operation. It can supply power stably during the normal system operation, but it has a poor ability to participate in system fault regulation. Literature (Li and Yuan, 2020) proposes a grid connection control strategy for PV/ES systems based on VSG, which can realize the friendly grid connection of PV and ES. However, it only considers that the ES is connected in parallel on the DC side of the PV system and cannot be used to adjust biogas generation.

To sum up, the current research on the coordinated control of PV/biogas/ES system for rural ecological breeding can be improved in the following aspects:

- (1) Operation strategy: it is necessary to comprehensively consider the different operation states such as normal and overload of the system and formulate the coordinated power management strategy of distribution source, load, and ES to maintain the balance between supply and demand.
- (2) Coordinated control strategy: the ES can participate in power regulation by improving the control, and be used for voltage support to improve the reliability of the power supply system.

This paper proposes a multi-mode coordinated control strategy of a grid-connected PV/biogas/ES combined generation system for rural ecological breeding. Firstly, a multi-mode operation strategy is presented by analyzing the different operating system conditions and the constraint

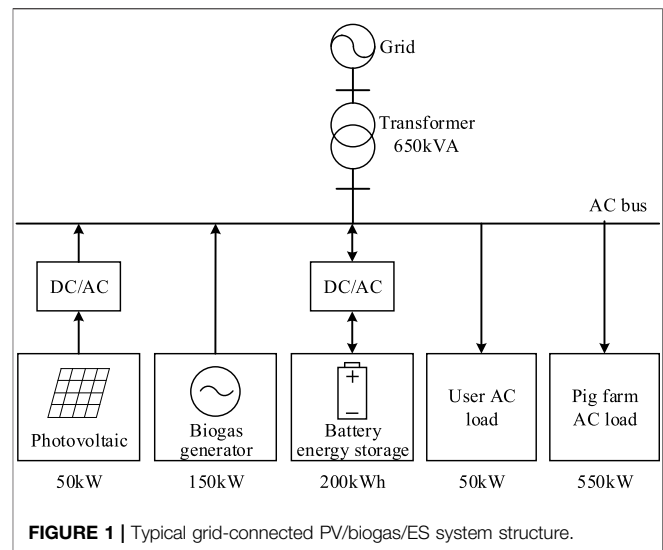

conditions of each component. Secondly, the flexible grid connection control strategy of the PV/biogas/ES system is proposed. Each unit can adjust the output power based on the multi-mode operation command to balance the supply and demand in the system. Then, considering the impact of failure, a voltage support control based on ES is proposed. Finally, a simulation model is built in MATLAB/Simulink to verify the reliability of the proposed strategy.

OPERATION ANALYSIS OF TYPICAL GRID-CONNECTED PV/BIOGAS/ES SYSTEM

Taking a rural pig farm in Jiangxi Province of China as the research object, its energy supply and consumption system are shown in **Figure 1**. The system includes PV, biogas and BESS, which cooperate with the grid to supply power to the AC loads in the pasture. In the figure, the load power of users and pig farms is the total power of all electric loads.

Operation Analysis of PV System

The equivalent model of PV generation can be expressed as **Eq. 1** (Tang et al., 2016).

$$I_{PV}(t) = I_{SC}(t) \left\{ 1 - C_1 \left[\exp\left(\frac{V_{PV}(t)}{C_2 V_{OC}(t)}\right) - 1 \right] \right\} \quad (1)$$

where $I_{PV}(t)$ and $V_{PV}(t)$ are the output current and voltage of the PV system at time t , respectively. Moreover, $I_{SC}(t)$ and $V_{OC}(t)$ express the system short-circuit current and open-circuit voltage at time t , in respect. Other parameters including, C_1 and C_2 are intermediate constants. To improve the energy efficiency, the PV system adopts the maximum power point tracking (MPPT) control to maximize the output of the system. If the output power tracked by MPPT is P_{MPPT} , PV (P_{PV}) power shall meet the condition **Eq. 2**

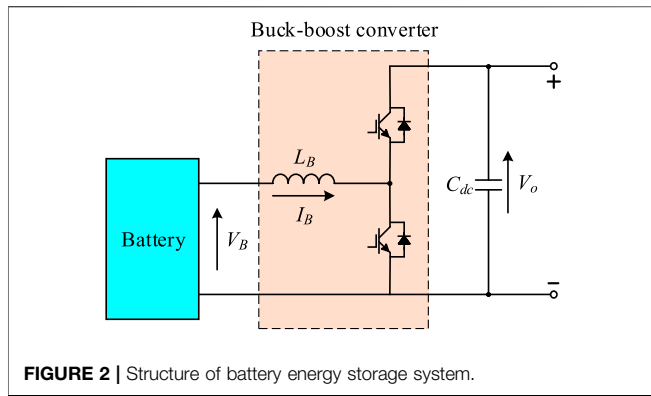

FIGURE 2 | Structure of battery energy storage system.

$$0 \leq P_{PV}(t) \leq P_{MPPT}(t) \quad (2)$$

The PV system should generally work in MPPT mode to improve energy efficiency and reduce carbon emission. The mentioned mode is to maximize the system output and realize local accommodation of renewable energy as much as possible. Moreover, the excess electric energy shall be absorbed by ES or flow into the grid in MPPT mode. It is worth noting that once the output power is higher than the overall demand of the system, it should be reduced to avoid failure. As the PV capacity in the proposed scene is small, the system operation in MPPT mode will be considered later.

Operation Analysis of Biogas Generation

The biogas generation system is directly connected to the grid through a synchronous generator, regarded as a stable voltage source. It is put into operation during the peak load period to avoid overload of the distribution transformer. Moreover, it exits the operation during the low load period to store biogas for power generation. The power of biogas generation (P_{BG}) can be expressed as Eq. 3

$$P_{BG} = b_{BG} P_{BG,N} \quad (3)$$

where b_{BG} can be either 0 or 1, used to control the biogas generation to put into/out of operation. $b_{BG} = 0$ means that it is closed, and $b_{BG} = 1$ means that it is open. $P_{BG,N}$ is the rated power of biogas generation.

Assuming that the capacity of the biogas storage tank is C_{BS} and the biogas reserve at time t is $S_{BG}(t)$, it shall meet the condition Eq. 4

$$p_{BS,min} C_{BS} \leq S_{BG}(t) \leq p_{BS,max} C_{BS} \quad (4)$$

where $p_{BS,max}$ and $p_{BS,min}$ are the upper and lower boundaries of the proportion of biomass reserves, respectively. In Figure 1, the value of the proposed parameters are: $C_{BS} = 300\text{kg}$, $p_{BS,min} = 0.2$, $p_{BS,max} = 0.9$.

Operation Analysis of ES

Due to the flexible and adjustable characteristics of ES, it can effectively improve the stability of a high proportion renewable energy system. The BESS includes a buck/boost converter for

TABLE 1 | Proportion and type of different loads.

Load name	Proportion (%)	Load type
Heating and cooling equipment	80	Non-adjustable
Warehouse handling equipment	3	Adjustable
Sewage system	3	Adjustable
Production machinery	12	Non-adjustable
Load of office building	1	Non-adjustable
Other loads	1	Non-adjustable

battery charging/discharging control. Its topology is shown in Figure 2 (Helling et al., 2019).

Owing to the battery capacity constraints, its charge/discharge power shall not exceed the specified range in actual operation. In addition, to prevent the battery from overcharging or discharging, its state of charge (SOC) should be kept within a safe range. In the selected scene, the BESS should meet the constraints Eq. 5

$$\begin{cases} -P_{ESc,max} \leq P_{ES} \leq P_{ESd,max} \\ SOCb_{min} \leq SOCb \leq SOCb_{max} \end{cases} \quad (5)$$

where P_{ES} is the discharge power of BESS; $P_{ESc,max}$ and $P_{ESd,max}$ are the maximum charging and discharging power allowed for BESS, respectively, and both values in this paper are 80kW. $SOCb$ is the SOC of the battery; $SOCb_{max}$ and $SOCb_{min}$ are the upper and lower boundaries of the SOC, usually 80% and 20%, respectively.

Operation Analysis of Adjustable Load

According to the operation characteristics, the loads can be divided into adjustable and non-adjustable loads. It is regarded as a non-adjustable load because the user load is small and difficult to adjust. The adjustable load of the farm mainly includes warehouse handling equipment and a sewage system. It can be cut off when the distribution transformer is overloaded and put into operation outside the peak load period. The load distribution in the breeding plant is presented in Table 1, in which the adjustable load accounts for 6%. At time t , the adjustable load power of the system (P_{adj}) can be expressed as Eq. 6

$$P_{adj}(t) = b_{HE}(t)P_{HE} + b_{SS}(t)P_{SS} \quad (6)$$

where $b_{HE}(t)$ and $b_{SS}(t)$ can be 0 or 1, which respectively represent the switching state of warehouse handling equipment and sewage system at time t . If the value is 0, it indicates the prohibited

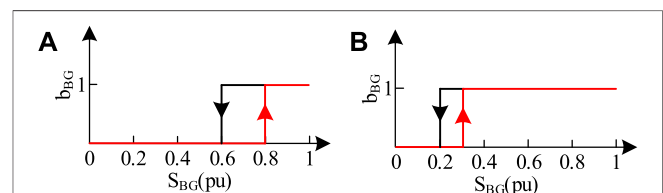

FIGURE 3 | Operation strategy of biogas generation: (A) Normal operation mode ($P_{load} < 0.75S_7$); (B) Overload prevention mode ($P_{load} \geq 0.75S_7$).

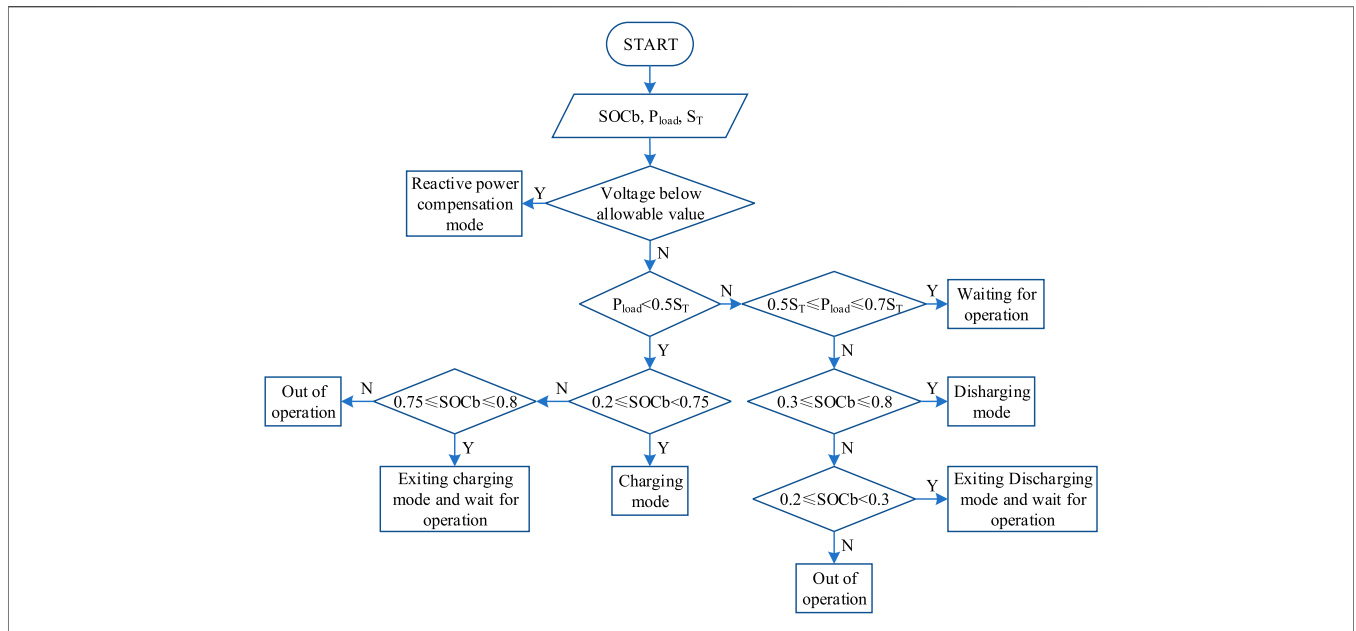

FIGURE 4 | Operation strategy of user side energy storage.

operation state. Otherwise, it indicates the allowed operation state. P_{HE} and P_{SS} are the rated power of warehouse handling equipment and sewage system, respectively.

FLEXIBLE RESOURCE OPERATION STRATEGY OF PV/BIOGAS/ES SYSTEM

The flexible resources of grid-connected PV/biogas/ES system include biogas generation, ES, and adjustable load. By formulating the operation strategy of flexible resources in different conditions, the orderly control of the system can be realized, which is vital for the stable operation of the system.

Operation Strategy of Biogas Generation

Typically, the amount of biogas storage restricts biogas generation. The biogas reserves decrease in the operation state of biogas generation, and they rise after exiting the operation. Therefore, the biogas storage data can be obtained for on/off control of biogas generation. Generally, when the transformer load rate reaches 80% of its capacity, it is called the overload operation state. In this condition, the transformer aging will

accelerate, and the system operation will be at risk. Consequently, to prevent the power supply transformer from running in the overload state, reasonably controlling the state of biogas generation is necessary.

Based on whether the load power (P_{load}) reaches 75% of the capacity of the distribution transformer (S_T), the biogas generation operation is divided into two modes, including normal operation and overload prevention modes. To prevent the biogas reserves (S_{BG}) from exceeding the limit and reserve a certain amount of biogas for peak load, the biogas generator is set to operate when $S_{BG} > 0.8pu$ and out of operation when $S_{BG} < 0.6pu$. In the overload prevention mode, the biogas generator is set to operate when $S_{BG} > 0.3pu$ and out of operation when $S_{BG} < 0.2pu$. The operation strategy of biogas generation is shown in Figure 3.

Operation Strategy of ES System

The ES operation process is mainly constrained by capacity and SOC of battery ($SOCb$). It is mainly used for peak shaving and valley filling, and grid fault response in this paper (Wu et al., 2021). During normal operation, the battery works in the peak shaving and valley filling mode, prioritizing discharge in the peak load period and charging in the low load period. Subsequently, when the grid voltage drops to the limit value, it switches to the reactive power compensation mode, and the BESS and VSC constitute a STATCOM/BESS to achieve voltage rise. The operation strategy of ES is shown in Figure 4.

To avoid the impact of voltage drop on the system, the reactive power compensation mode has higher priority with respect to the peak shaving and valley filling mode. When a fault is detected, the latter mode is activated immediately to provide reactive power to the grid. In normal conditions, the ES operation strategy is as follows:

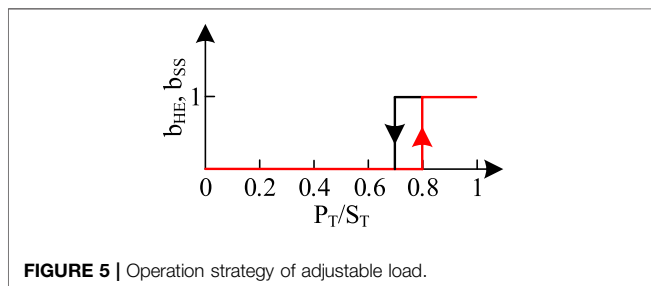

FIGURE 5 | Operation strategy of adjustable load.

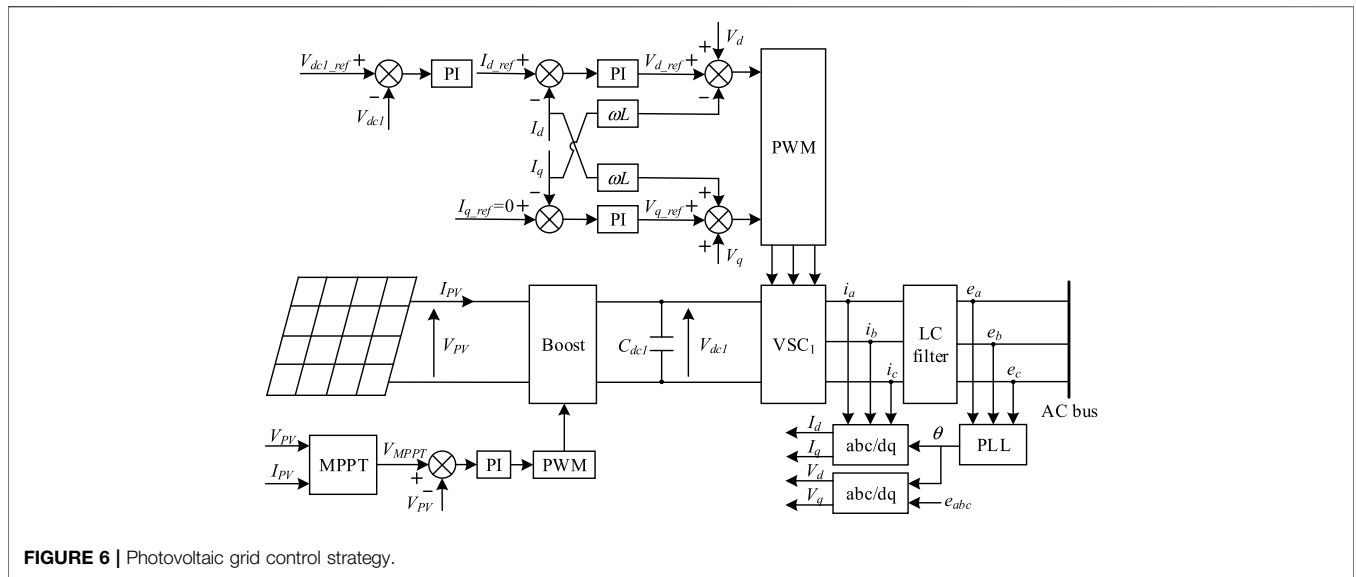

FIGURE 6 | Photovoltaic grid control strategy.

- (1) When $P_{load} < 50\%S_T$, the ES prioritizes absorbing power from the grid. If $0.2 \leq SOCb < 0.75$, it is charged at the rated power. If $0.75 \leq SOCb \leq 0.8$, it exits the charging mode and waits for operation. If $SOCb < 0.2$ or $SOCb > 0.8$, it would be out of operation.
- (2) When $50\%S_T \leq P_{load} \leq 70\%S_T$, the ES is in the waiting operation state to prevent the overload of the transformer caused by the charging of the battery.
- (3) When $P_{load} > 70\%S_T$, the ES prioritizes output power to the grid. If $0.25 \leq SOCb < 0.8$, it is discharged at the rated power. If $0.2 \leq SOCb \leq 0.25$, it exits the discharging mode and waits for operation. If $SOCb < 0.2$ or $SOCb > 0.8$, it would be out of operation.

Operation Strategy of Adjustable Load

When the distribution transformer is overloaded, it is necessary to cut off a part of the loads to prevent failure. Removing the adjustable load has the least loss to the system, so it is of great significance in participating in system power regulation. Therefore, the proposed strategy focuses on adjustable load, and non-adjustable load is not

considered. The operation state of adjustable load can be realized by controlling binary variables b_{HE} and b_{SS} . In this case, if the transformer power (P_T) is greater than $80\%S_T$, b_{HE} and b_{SS} are set to 0, and if P_T is less than $70\%S_T$, b_{HE} and b_{SS} are set to 1. The operation strategy of adjustable load is shown in Figure 5.

COORDINATED CONTROL STRATEGY OF PV/BIOGAS/ES SYSTEM

The coordinated control strategy is proposed to realize the stable operation of the PV/biogas/ES system based on the operation strategy. The flexible resources can adjust the operation mode according to the real-time control instructions to maintain the system reliability. Through the proposed coordinated operation and control strategy, the system can have the following functions:

- (1) Maintain the balance between supply and demand of energy,
- (2) Avoid long-term heavy load operation of distribution transformer,
- (3) The system has reactive power compensation capability and certain frequency modulation capability.

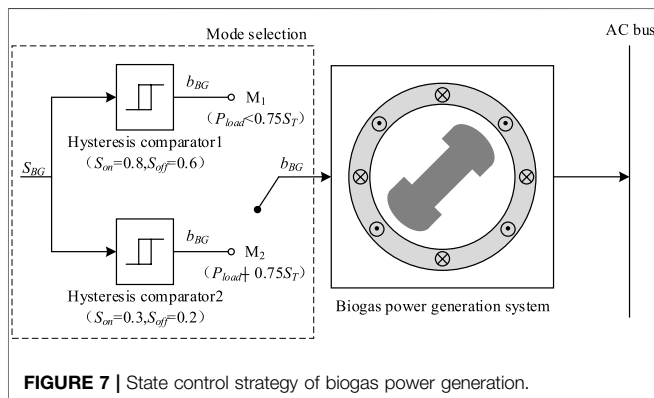

FIGURE 7 | State control strategy of biogas power generation.

Control Strategy of PV System

Generally, the capacity of a distributed PV system in a rural grid is small, and it only operates in the grid-connected state. Thus, it does not participate in the system power regulation. In this paper, MPPT and dq decoupling controls are used to realize the grid connection of the PV system (Hassaine et al., 2014; Jiang et al., 2021). The control strategy of the PV system is illustrated in Figure 6.

Control Strategy of Biogas Generation

The biogas generation can provide constant and reliable power to the load when it operates stably. According to the analysis in

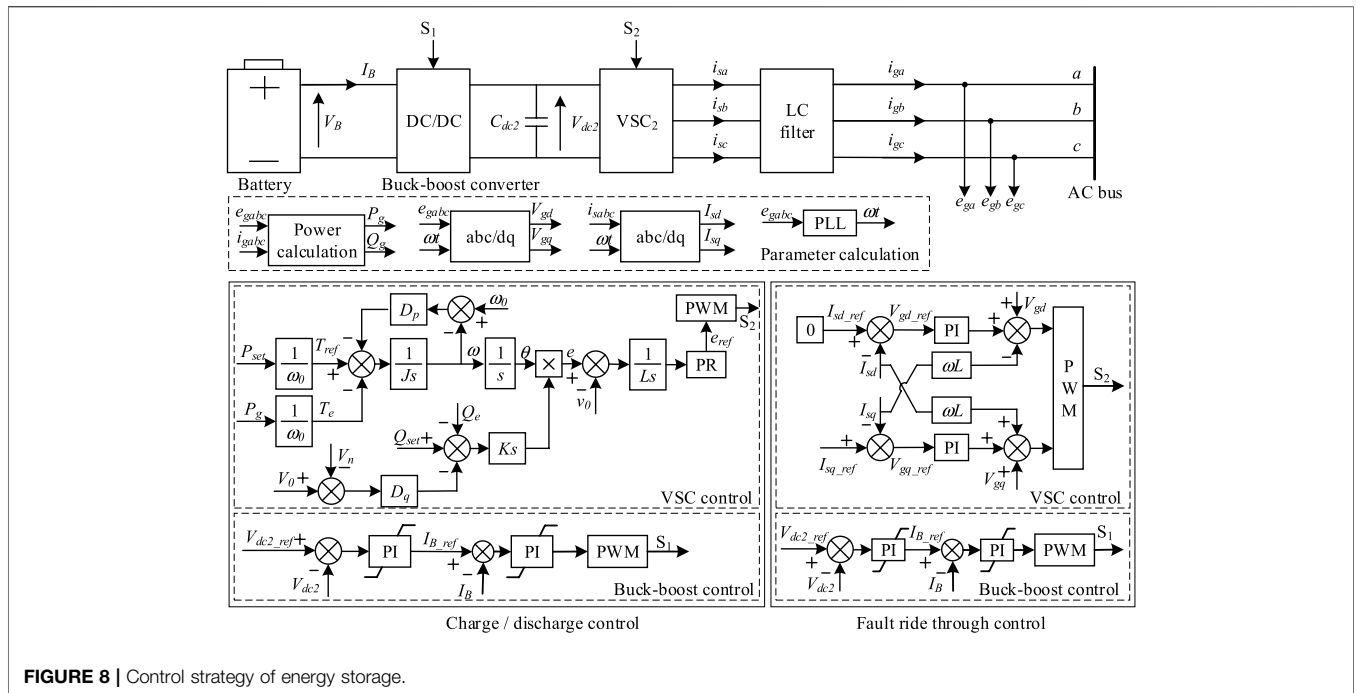

FIGURE 8 | Control strategy of energy storage.

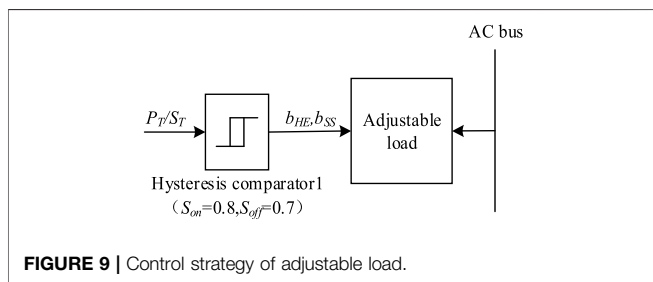

FIGURE 9 | Control strategy of adjustable load.

TABLE 2 | Simulation parameters.

Parameter name	Value
Rated power of PV	50kW
Rated power of biogas generator	150kW
Capacity of ES	200kWh
Rated charging/discharging power of ES	50kW
Total load	600kW
Distribution transformer capacity	650kW
Voltage of AC bus	380V
DC voltage of PV/ES	800V
Rated frequency	50Hz

Section 3.1, the state of biogas generation can be formulated based on the system operation. Therefore, its operating mode can be formulated by collecting real-time data on biogas reserve (S_{BG}) and load power (P_{load}), as shown in Figure 7. In this figure, M_1 represents the normal operation mode, and M_2 represents the overload prevention mode. The output characteristics of the

hysteresis comparator selected for control are: if $S_{BG} \geq S_{on}$, $b_{BG} = 1$, and if $S_{BG} \leq S_{off}$, $b_{BG} = 0$.

Control Strategy of ES System

The control strategy of ES includes VSC control and charge/discharge control of the battery. According to different operating states, it can be divided into four working modes as:

- (1) charging,
- (2) discharging,
- (3) waiting for an operation,
- (4) reactive power compensation.

When the ES works in the charging or discharging mode, it absorbs or sends power to the grid at the rated power, respectively. In this situation, VSG control is used to realize the grid connection. Compared with traditional PQ control, the ES has a certain frequency and voltage regulation ability, which are helpful to improve the system stability. When the ES works in the waiting operation mode, it exits the current operation mode and waits for the following control command. When the ES works in reactive power compensation mode, ES operates as a STATCOM to provide reactive power to the grid. The control strategy of ES is shown in Figure 8.

Control Strategy of Adjustable Load

Figure 9 depicts the control strategy of an adjustable load which is similar to biogas generation control. The P_T is collected in real-time for the state control of the adjustable load. When P_T is higher than the limit value, the control system leads the adjustable load

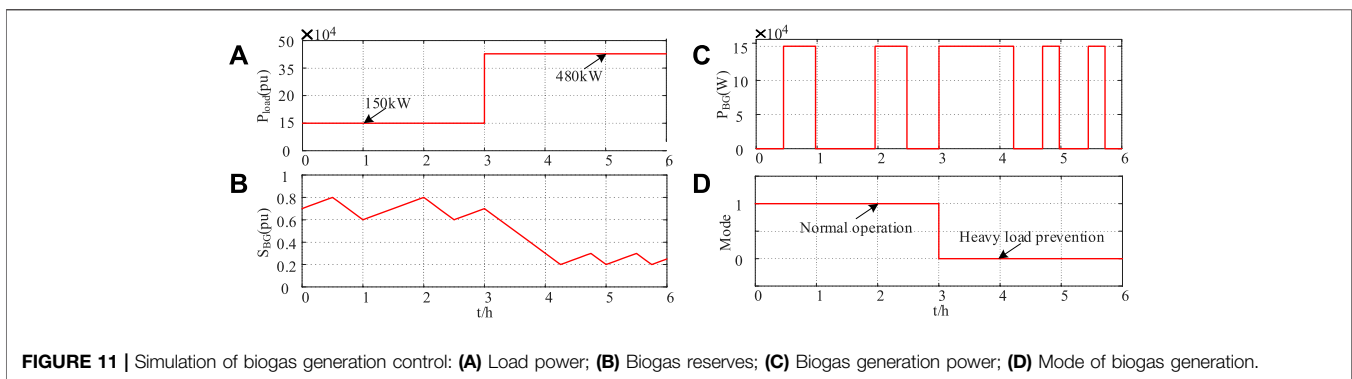
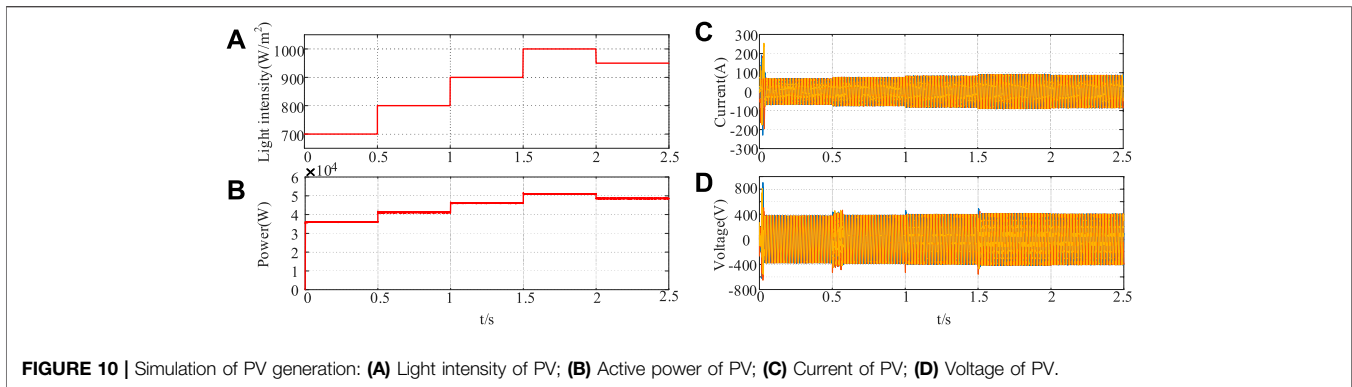

to exit the operation and allows it to operate when it is lower than the set range.

SIMULATION ANALYSIS

The grid-connected PV/biogas/ES system model is built in MATLAB/Simulink, as shown in **Figure 1**. Firstly, the operation processes of PV, biogas generation, and ES in different conditions are simulated. Then, the overall operation of the system is considered. The main parameters are shown in **Table 2**.

Simulation of PV Generation

The PV system model is simulated based on **Figure 6**. Moreover, the sudden change of light intensity is modeled by setting a step change to verify the reliability of the grid connection strategy of the PV system. The simulation results are presented in **Figure 10**. The simulation results show that with the change of light intensity, MPPT can track the maximum power point and maximize the power output of the AC bus.

Simulation of Biogas Generation

To simplify the biogas generation process, it is assumed that when biogas generation is out of operation, the biogas reserves (S_{BG}) increase at the speed of 0.2pu/h. Furthermore, when the biogas generation is put into operation, it is reduced at the

speed of 0.4pu/h. The initial amount of S_{BG} is defined as 0.7pu, and the load power (P_{load}) increases with time, which reaches 80% S_T in the 3rd hour. The simulation results are shown in **Figure 11**. As can be seen, when the P_{load} is lower than the limit, the biogas generation works in the normal operation mode to prevent the biogas reserves from exceeding the limit. When the load is higher than the limit, biogas generation works in the overload prevention mode, and biogas reserves are used to generate power to avoid the overload of the distribution transformer.

Simulation of ES System

The operation process of the ES in different modes is simulated. In the reactive power compensation mode, the bus voltage must drop to 0.6pu at 0.1s. The compensation transient process can be observed when the ES system is set into operation at 0.2s. In the normal operation mode, the ES is set to discharge at rated power in 0–0.5s, charge at rated power in 0.5–1s, work in the waiting operation mode in 1–1.5s, and discharge at rated power in 1.5–3s. The system frequency drops to 49.8Hz at 2s and returns to 50Hz at 2.5s. The simulation results in the two modes are shown in **Figure 12**.

Simulation of the Whole System

The output power of each component in different conditions can be obtained by simulating the change of PV power (P_{PV}) and load power with time. The changes of P_{PV} with time are as follows: $P_{PV} = 0$ kW in 0–0.5s, 10 kW in 0.5–1s, 30 kW in 1–1.5s,

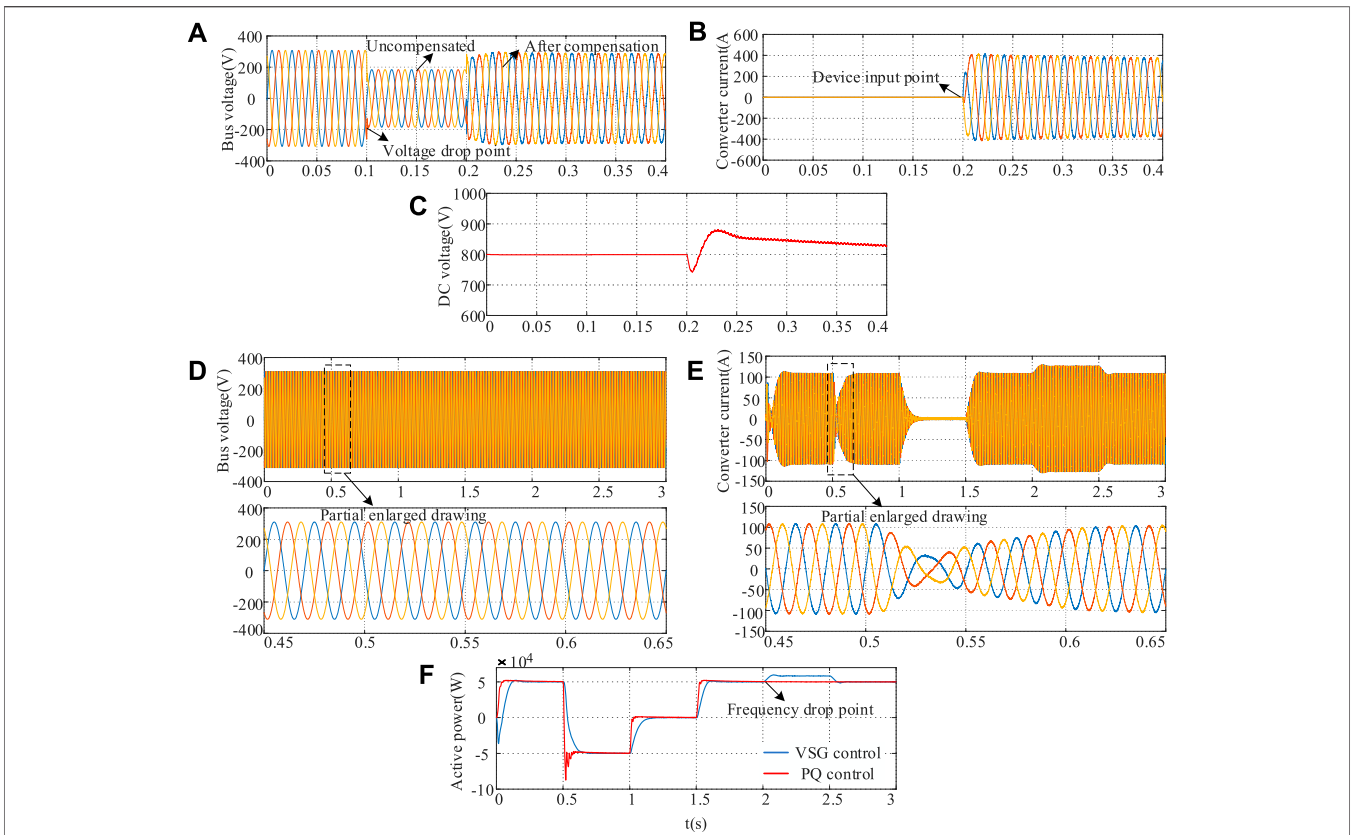

FIGURE 12 | Operation process of energy storage in different mode: **(A)** Bus voltage in reactive power compensation mode; **(B)** Converter current in reactive power compensation mode; **(C)** DC voltage in reactive power compensation mode; **(D)** AC bus voltage in normal operation mode; **(E)** Converter current in normal operation mode; **(F)** Active power of ES in different control.

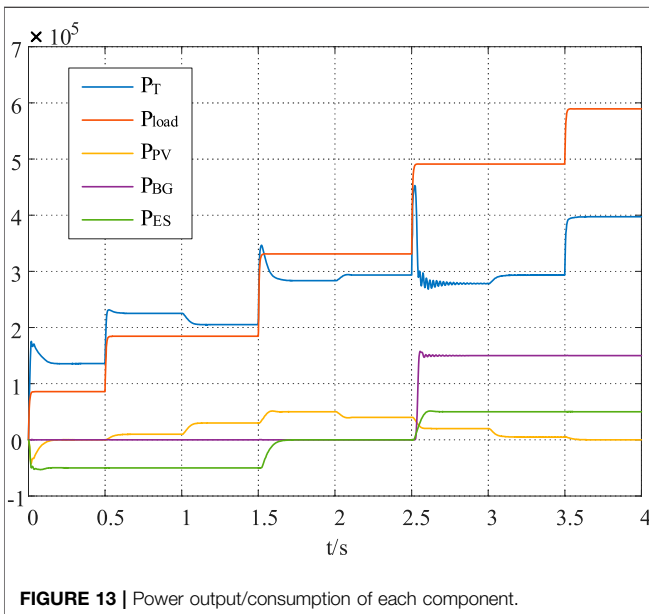

FIGURE 13 | Power output/consumption of each component.

50kW in 1.5–2s, 40kW in 2–2.5s, 20kW in 2.5–3s, and 5kW in 3–3.5s. The changes of P_{load} over the time are set to: $P_{load} = 86\text{kW}$ in 0–0.5s, 186kW at 0.5–1.5s, 336kW at 1.5–2.5s, 500kW at

2.5–3.5s and 600kW at 3.5s. The output power of PV, load, biogas generation, ES, and transformer are shown in **Figure 13**. As can be seen in the results, the biogas generation, ES, and adjustable load can switch the working modes according to the operating conditions to prevent overloading of the distribution transformer due to the load increase.

CONCLUSION

In this paper, a multi-mode operation and coordinated control strategy of the PV/biogas/ES system was proposed to realize its orderly control, aiming at the energy supply and consumption system of a rural ecological breeding scene. The main conclusions are as follows:

- (1) The biogas generation state can be adjusted according to the load condition to prevent the biogas reserves from exceeding the limit and leave a margin for operation during the peak load period. Using a hysteric comparator can prevent the harm caused by frequent switching of the biogas generation.
- (2) In terms of the operation and control strategy of the ES, two operation modes are set, including normal operation and reactive power compensation. During normal operation, the

control method based on VSG and quasi-PR is adopted for considering a certain frequency modulation and voltage regulation ability in the ES. In case of bus voltage drop, it can operate as STATCOM/BESS to provide voltage support to the grid.

- (3) The adjustable load can change its operation mode based on the load power to improve the power supply reliability of the system.

DATA AVAILABILITY STATEMENT

The original contributions presented in the study are included in the article/supplementary material, further inquiries can be directed to the corresponding author.

REFERENCE

- Al-Masri, H. M. K., Al-Sharqi, A. A., Magableh, S. K., Al-Shetwi, A. Q., Abdolrasol, M. G. M., and Ustun, T. S. (2022). Optimal Allocation of a Hybrid Photovoltaic Biogas Energy System Using Multi-Objective Feasibility Enhanced Particle Swarm Algorithm. *Sustainability* 14 (2), 685. doi:10.3390/su14020685
- Bär, K., Wageneder, S., Solka, F., Saidi, A., and Zörner, W. (2020). Flexibility Potential of Photovoltaic Power Plant and Biogas Plant Hybrid Systems in the Distribution Grid. *Chem. Eng. Technol.* 43 (8), 1571–1577. doi:10.1002/ceat.202000025
- Bhattacharjee, A., Samanta, H., Ghosh, A., Mallick, T. K., Sengupta, S., and Saha, H. (2021). Optimized Integration of Hybrid Renewable Sources with Long-Life Battery Energy Storage in Microgrids for Peak Power Shaving and Demand Side Management under Different Tariff Scenario. *Energy Tech.* 9 (9), 2100199. doi:10.1002/ente.202100199
- Colmenar-Santos, A., Bonilla-Gómez, J.-L., Borge-Diez, D., and Castro-Gil, M. (2015). Hybridization of Concentrated Solar Power Plants with Biogas Production Systems as an Alternative to Premiums: the Case of Spain. *Renew. Sustain. Energy Rev.* 47, 186–197. doi:10.1016/j.rser.2015.03.061
- Deng, J., Jiang, F., Wang, W. Y., He, G. X., Zhang, X. H., and Liu, K. C. (2022). Low-carbon Optimized Operation of Integrated Energy System Considering Electric Heating Flexible Load and Hydrogen Energy Refined Modeling. *Power Syst. Technol.* 46 (5), 1692–1704. doi:10.13335/j.1000-3673.pst.2021.1373
- Gai, X., Wang, Y., Chen, R., and Zou, L. (2019). Research on Hybrid Microgrid Based on Simultaneous Ac and Dc Distribution Network and its Power Router. *Energies* 12 (6), 1077. doi:10.3390/en12061077
- Hassaine, L., Olias, E., Quintero, J., and Salas, V. (2014). Overview of Power Inverter Topologies and Control Structures for Grid Connected Photovoltaic Systems. *Renew. Sustain. Energy Rev.* 30, 796–807. doi:10.1016/j.rser.2013.11.005
- Helling, F., Glöck, J., Singer, A., Pfisterer, H.-J., and Weyh, T. (2019). The AC Battery - A Novel Approach for Integrating Batteries into AC Systems. *Int. J. Electr. Power & Energy Syst.* 104, 150–158. doi:10.1016/j.ijepes.2018.06.047
- Jiang, F., Peng, X., Tu, C., Guo, Q., Deng, J., and Dai, F. (2021). An Improved Hybrid Parallel Compensator for Enhancing PV Power Transfer Capability. *IEEE Trans. Ind. Electron.* doi:10.1109/TIE.2021.3121694
- Li, C., and Yuan, S. (2020). Research on Frequency Modulation Control of Photovoltaic Power Generation System Based on VSG. *Int. J. Low-Carbon Technol.* 16 (16), 287–293. doi:10.1093/ijlct/ctaa054
- Li, H., Fu, L., Zhang, Y., and Xiong, Y. (2022). A Dynamic and Cooperative Control Strategy for Multi-Hybrid Energy Storage System of DC Microgrid Based on SOC. *Front. Energy Res.* 9, 795513. doi:10.3389/fenrg.2021.795513
- Liu, B., Wu, W., Zhou, C., Mao, C., Wang, D., Duan, Q., et al. (2019). An AC-DC Hybrid Multi-Port Energy Router with Coordinated Control and Energy Management Strategies. *IEEE Access* 7 (99), 109069–109082. doi:10.1109/ACCESS.2019.2933469

AUTHOR CONTRIBUTIONS

XH Z and GX H contributed to the conception and design of the proposed strategy. All authors wrote and edited the manuscript.

FUNDING

This work is supported by the science and technology project of State Grid Corporation of China: Research on cloud-edge collaboration management and control technology of rural energy supply and consumption for smart energy service platform (5400-202125158A-0-0-00).

- Merahi, F., Badoud, A. E., and Mekhilef, S. (2021). A Novel Power Management Strategies in PV-wind -based Grid Connected Hybrid Renewable Energy System Using Proportional Distribution Algorithm. *Int. Trans. Electr. Energy Syst.* 31 (7), e12931. doi:10.1002/2050-7038.12931
- Mottet, A., and Tempio, G. (2017). Global Poultry Production: Current State and Future Outlook and Challenges. *World's Poult. Sci. J.* 73 (2), 245–256. doi:10.1017/S0043933917000071
- Sayed, E. T., Wilberforce, T., Elsaid, K., Rabaia, M. K. H., Abdelkareem, M. A., Chae, K.-J., et al. (2021). A Critical Review on Environmental Impacts of Renewable Energy Systems and Mitigation Strategies: Wind, Hydro, Biomass and Geothermal. *Sci. Total Environ.* 766 (5), 144505. doi:10.1016/j.scitotenv.2020.144505
- Scarlat, N., Dallemand, J.-F., and Fahl, F. (2018). Biogas: Developments and Perspectives in Europe. *Renew. Energy* 129, 457–472. doi:10.1016/j.renene.2018.03.006
- Tang, R.-L., Wu, Z., and Fang, Y.-J. (2016). Maximum Power Point Tracking of Large-Scale Photovoltaic Array. *Sol. Energy* 134, 503–514. doi:10.1016/j.solener.2016.05.026
- Vivas, F. J., De las Heras, A., Segura, F., and Andújar, J. M. (2017). A Review of Energy Management Strategies for Renewable Hybrid Energy Systems with Hydrogen Backup. *Renew. Sustain. Energy Rev.*, 82(pt.1), 126–155. doi:10.1016/j.rser.2017.09.014
- Wu, T., Wang, J., Qi, Y., and Rong, F. (2021). Research on Variable Parameter Power Differential Charge-Discharge Strategy of Energy Storage System in Isolated Island Operating Microgrid. *Int. J. Low-Carbon Technol.* 16 (2), 635–642. doi:10.1093/ijlct/ctaa098

Conflict of Interest: XZ, GH, and CX were employed by the company China Electric Power Research Institute Co., Ltd. JX and WH were employed by the company Electric Power Research Institute of State Grid Jiangxi Electric Power Co., Ltd.

Publisher's Note: All claims expressed in this article are solely those of the authors and do not necessarily represent those of their affiliated organizations, or those of the publisher, the editors and the reviewers. Any product that may be evaluated in this article, or claim that may be made by its manufacturer, is not guaranteed or endorsed by the publisher.

Copyright © 2022 Zhang, He, Xiong, He and Xiao. This is an open-access article distributed under the terms of the Creative Commons Attribution License (CC BY). The use, distribution or reproduction in other forums is permitted, provided the original author(s) and the copyright owner(s) are credited and that the original publication in this journal is cited, in accordance with accepted academic practice. No use, distribution or reproduction is permitted which does not comply with these terms.