



Concepts, Structure and Developments of High-Reliability Cyber-Physical Fusion Based Coordinated Planning for Distribution System

Chong Gao¹, Tianlin Wang¹, Huazhen Cao¹, Ziyao Wang², Tao Yu^{2*} and Ran Cheng¹

¹Grid Planning and Research Center, Guangdong Power Grid Co., Ltd., CSG, Guangzhou, China, ²Electric Power College of South China University of Technology, Guangzhou, China

OPEN ACCESS

Edited by:

Bo Yang,
Kunming University of Science and
Technology, China

Reviewed by:

Yang Li,
Northeast Electric Power University,
China
Xuehan Zhang,
Korea University, South Korea

*Correspondence:

Tao Yu
taoyu1@scut.edu.cn

Specialty section:

This article was submitted
to Smart Grids,
a section of the journal
Frontiers in Energy Research

Received: 20 April 2021

Accepted: 06 May 2021

Published: 22 June 2021

Citation:

Gao C, Wang T, Cao H, Wang Z, Yu T
and Cheng R (2021) Concepts,
Structure and Developments of High-
Reliability Cyber-Physical Fusion
Based Coordinated Planning for
Distribution System.
Front. Energy Res. 9:697959.
doi: 10.3389/fenrg.2021.697959

Coordinated control is imperative for the distribution network with the integration of wind power, photovoltaic system, and energy storage system. Meanwhile, the advanced automation terminal, intelligent control technology, and information communication technologies have greatly promoted the informatization of distribution networks which also increase the correlation between the physical system (primary system) and the cyber system (secondary system). Hence, it is critical to comprehensively coordinate the planning of the cyber-physical system for building a highly reliable power grid. This work summarizes a series of challenges brought by the highly coupled cyber-physical system, such as the primary and secondary collaborated planning models and solution algorithms. Then, the reliability assessment theories of cyber-physical systems and their application in distribution network planning models are introduced. Finally, three development directions of distribution network planning in the future are proposed, considering primary and secondary system coordinated planning.

Keywords: reliability, cyber-physical system, primary and secondary system, coordinated planning, distribution system

INTRODUCTION

With the rapid development of information technology, communication technology, and electronic control technology, the cyber system has gradually become the core framework of power systems. As the coupling degree between the physical system (primary system) and cyber system (secondary system) increase, it is of great significance to realize coordinated planning of the distribution network, distribution automation (DA), and the communication network, etc (Cortes et al., 2017; Sun and Yang, 2020).

Primary system planning mainly includes distribution network structure determining, substation locating, and sizing. Particularly, the reliability evaluation for the primary system possesses huge challenges due to the renovation of microgrid (MG), DC distribution, and integrated energy system (IES), as well as the reformation of demand response (DR) and electric power system (Lotfi and Khodaei, 2017). The above factors further complicate the distribution network planning models, which result in lots of novel planning methods and solution algorithms in this field (Georgilakis and Hatziargyriou, 2015).

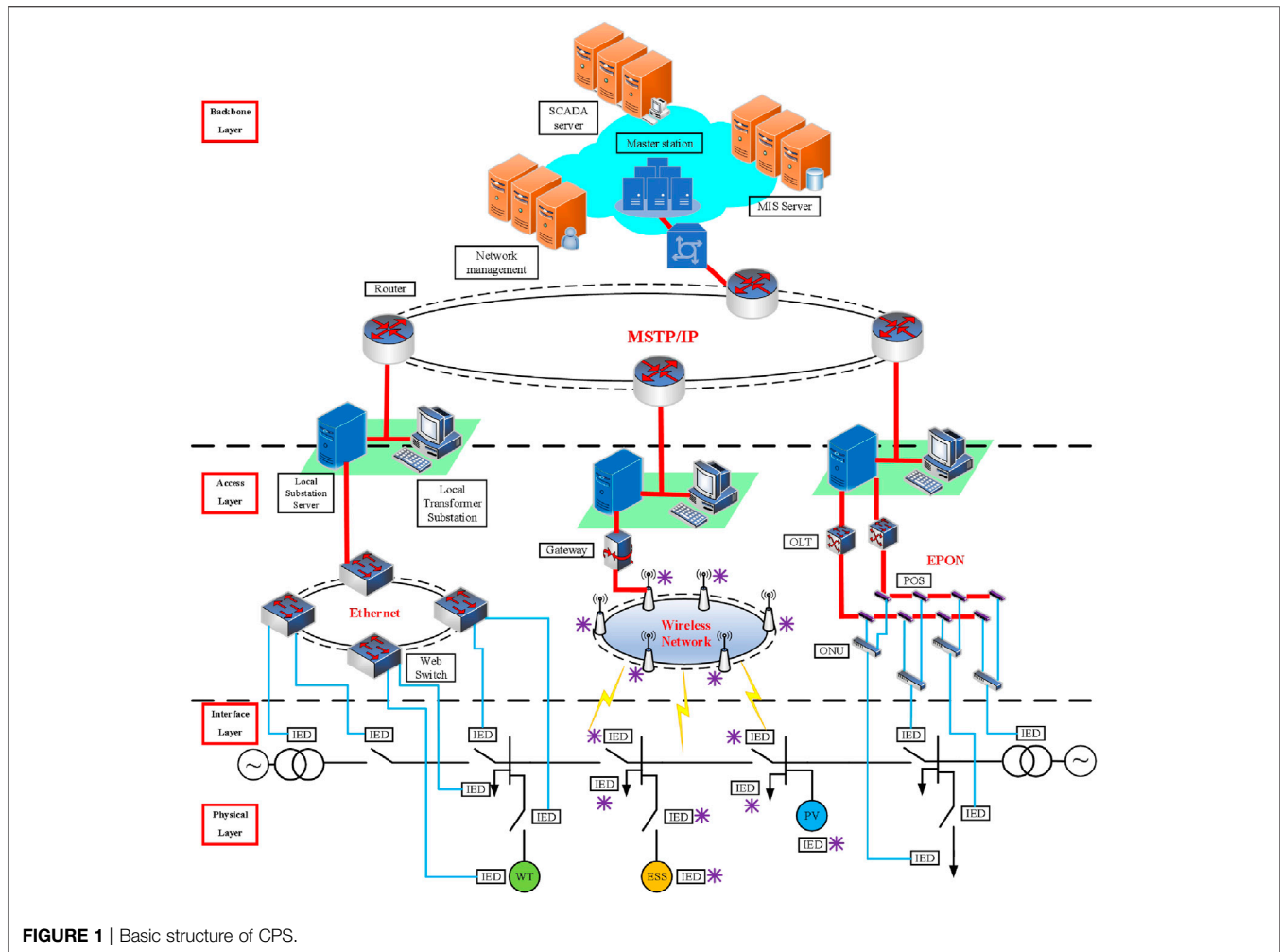

Secondary system planning is mainly composed of distribution automation system (DAS) planning and communication system planning. In the highly automated and information-based smart grid, a large amount of data information emerges along with data acquisition and control equipment that require a secondary system for synthetical management and analysis. Moreover, the stable operation of the power grid highly depends on the secondary system, which is the solid guarantee for building a strong power grid. However, in the process of promoting the automation and intelligence of the distribution network, the secondary system is a potential factor threatening the reliable operation of the primary system, for example, the well-known accidents at the Iran nuclear power plant blackout of 2010 (Farwell and Rohozinski, 2011) and Ukraine large blackout in 2015 (Liang et al., 2017). Secondary system failures directly or indirectly cause power grid performance deterioration and even load shedding, resulting in vast economic and social losses.

To improve the overall efficiency of the distribution network, it is necessary to implement the coordinated planning of primary and secondary systems from the perspective of global optimization (Gholizadeh et al., 2018). This paper introduces the basic contents of cyber-physical fusion based coordinated planning

for the distribution network. The challenges of strongly coupled primary and secondary system planning are discussed from three aspects, i.e., secondary system reliability evaluation, coordinated planning models of the primary and secondary system, and solution algorithms. Besides, the current research status of high-reliability primary and secondary system planning from complex networks and optimization is also given. Lastly, this work summarizes the conclusions of primary and secondary coordinated planning for a highly reliable distribution network and proposes three future research directions from mathematical models, optimization algorithms, and engineering practices.

CYBER-PHYSICAL FUSION BASED COORDINATED PLANNING FOR DISTRIBUTION NETWORK

Basic Framework of the Primary and Secondary System

The primary system consists of a power supply, network frame, and switchgear coupled with a secondary system including an

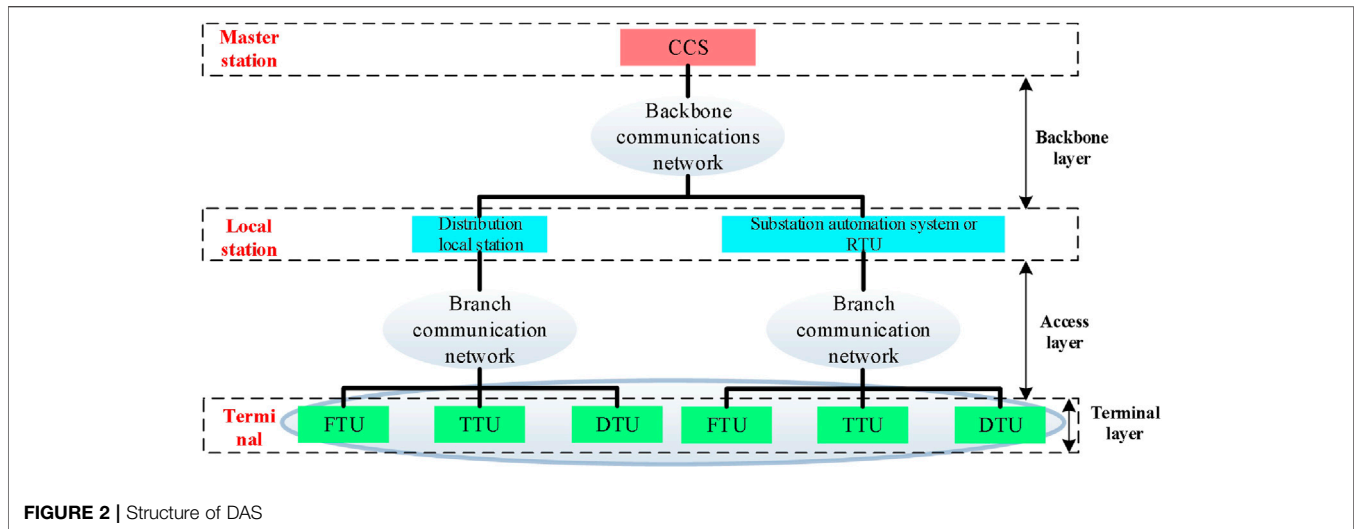

automation system and communication system, which collaboratively establish the highly intelligent, strong, and inseparable distribution network. Note that the above definitions are different from the literature (Gholizadeh et al., 2018), in which primary system and secondary system refer to a high voltage network and low voltage network, respectively. The research and development of cyber-physical system (CPS) related theories (Humayed et al., 2017) explain the coupling relationship between the primary system and secondary system (Liu et al., 2018), and the basic structure of CPS is shown in Figure 1. The interface equipment connecting the primary system and secondary system in this figure is an intelligent electronic device (IED), which includes a data acquisition unit, data monitoring unit, relay protection unit, and control unit. In distribution network CPS, the primary system is composed of power supply, transformer, switch equipment, and line, while secondary system incorporates IED, communication line, switch, server, control decision master station, etc. Moreover, CPS can be divided into four layers, namely backbone network, access network, an interface layer, and physical layer.

Secondary System

Reasonable planning for the secondary system of the distribution network could greatly reduce the number of outage users and outage time, which is an effective way to improve the overall reliability of the distribution network (Popovic et al., 2019).

Distribution Automation System

According to the IEEE PES distribution automation team, DAS is defined as a system that enables power companies to realize remote monitor, manage, and operate distribution components in real-time. DAS is mainly composed of a central control system (CCS), distribution electronic station (optional), distribution terminal, and communication equipment, which is shown in Figure 2.

Feeder automation (FA) is one of the core contents of DA. When feeder failure occurs, FA can automatically or semi-automatically realize fault location, fault isolation, and power

transfer to reduce the outage time for improving the reliability of the distribution network. If FA fails to work due to terminal failure or communication fault, it will weaken power reliability and even expand fault range. Therefore, the modeling and planning of FA are two key points in the coordinated planning of distribution networks considering reliability. Common distribution automation modes are shown in Appendix A.

The coverage of FTU and the selection of fault handling mode have a great impact on the reliability of the distribution network (Heidari and Fotuhi-Firuzabad, 2019). Especially, different automatic fault handling modes (e.g., local, centralized, and distributed), which rely on different FTU functions. FTU configuration based on primary equipment or collaborated planning of primary and secondary equipment has attracted the attention of scholars. For example, the “three remotes” terminals are equipped in most distribution network projects of China. This kind of mode improves the reliability of the distribution network, but blind allocation will reduce returns. In European countries, the investment subjects of DAS are distribution companies (DISCOs), which focus on both reliability and economy.

Distribution Communication System

The reliability of communication networks includes topology reliability and delay reliability. There are differences between different communication technologies. In general, optical fiber communication has strong reliability with expensive costs. The laying of optical cable often involves the restrictions of municipal construction. Wireless communication has the advantages of convenient maintenance and a small investment, but it will lead to communication delays due to information blocking. Furthermore, carrier communication and satellite communication are not widely used at present because of their inherent defects.

Different communication methods will affect the function realization of DAS and the reliability of the primary system. Thus, the communication mode planning and topology planning

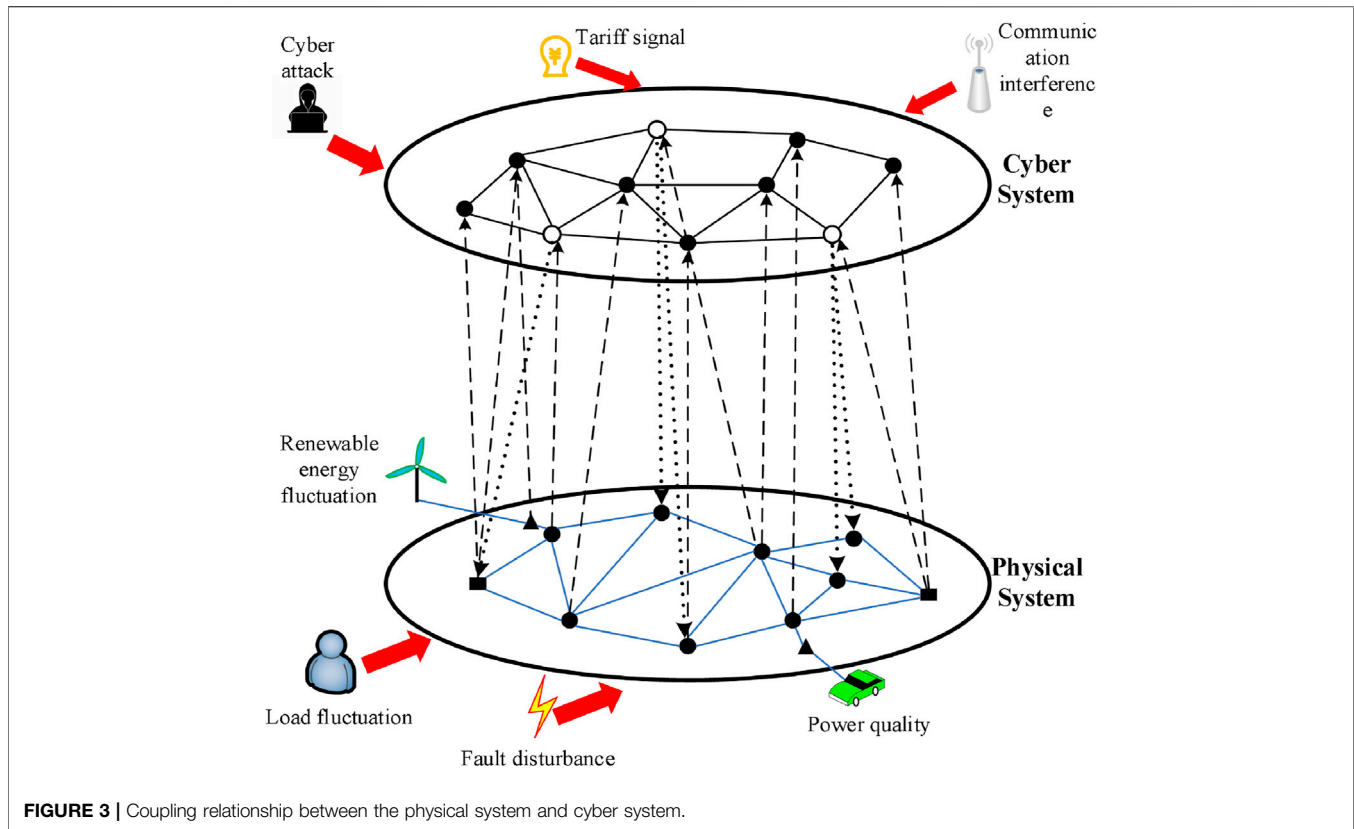

need to be simultaneously considered for high-reliability distribution network coordinated planning. Common distribution communication modes are shown in **Appendix B**.

CHALLENGES OF STRONG COUPLING PRIMARY AND SECONDARY SYSTEM PLANNING

There is a strong coupling between the primary and secondary systems, as shown in **Figure 3**. The primary system is easily affected by load fluctuation, fault disturbance, and renewable energy connection, while the secondary system is often influenced by electricity price, network attack, and communication interference. For deeply coupled CPS, these disturbances are potential threats that can reduce the reliability of the distribution network.

Influence of Secondary System on Reliability

In traditional high-reliability distribution network planning, N-1 Criterion (Lin et al., 2019) is often adopted to evaluate risk value (Esmaeeli et al., 2017). Besides, simulation methods and analytical algorithms are used to evaluate the reliability of the distribution network and locate the weak links in the primary system. The abnormality conditions of the secondary system are caused by data measuring instruments, automated terminal

equipment, communication standard, and network topology, which can increase the operational risk of the primary system. The influence of these factors on the reliability of the distribution system mainly includes the following aspects:

- (1) The automatic terminal equipment of the secondary system is key to realizing feeder automation;
- (2) The communication topology of the secondary system is the premise of accurate fault location in the primary system (Harri et al., 2019);
- (3) Communication mode and protocol affect the power supply reliability of primary system via DAS (Cai et al., 2019);
- (4) The data collected by the secondary system contains valuable information for operation planning and decision (Colak et al., 2016; Tuballa and Abundo, 2016; Dileep, 2020).

Coordinated Planning Model

Power grid planning can be divided into two types: distribution network expansion planning (DSEP) and planning from scratch.

At present, research on primary system planning is relatively mature, but the study about connection modes, extreme environment, load uncertainties, and DG uncertainties still needs to be supplemented and improved. In particular, connection modes are diverse, including radial type, N-1 ring network, and composite structure, etc., which have a significant impact on the reliability of the primary system. The distribution network is highly sensitive to the climate condition and geographical location which may lead to grid fault. Moreover,

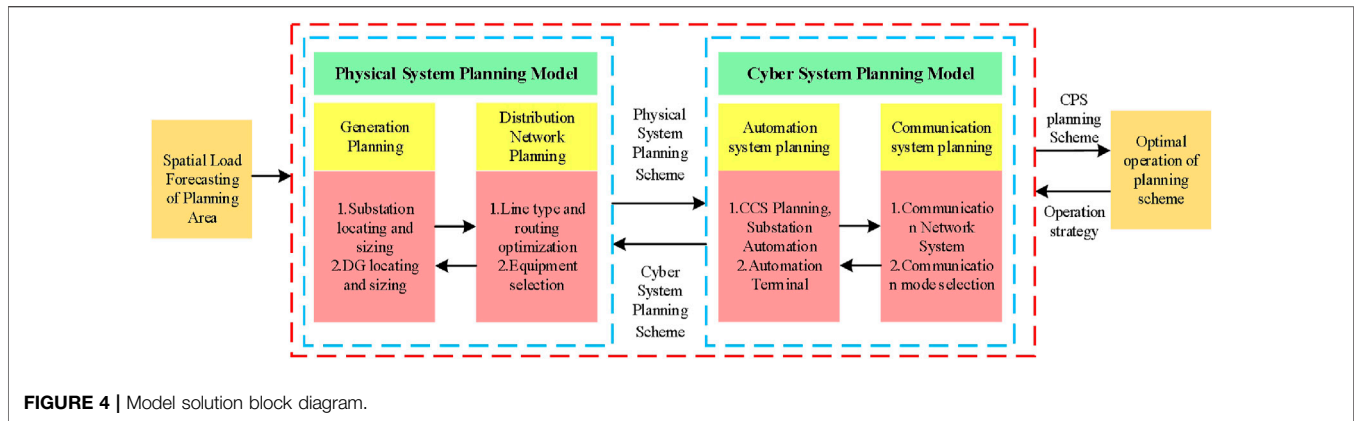

the output of DGs (e.g., wind energy conversion system, photovoltaic system, etc.) in the power supply side also have uncertainties due to the randomness and intermittency of renewable energy. The operating characteristics of the load side have changed because of the implementation of demand response and power market reforms. Hence, the modeling and calculation of the above uncertain factors are crucial but thorny tasks for researchers.

The planning level of the secondary system mainly includes automation terminal layout planning and communication topology planning. The former is equipped with automatic terminals on switching elements (such as section switch, tie switch, circuit breaker, etc.) to locate, isolate, and recover faults in the distribution network. Research on communication topology planning mainly focuses on the access layer since the backbone layer is relatively simple, which only has a small optimization space. Access layer topology planning optimizes the connection relationship between the terminal nodes, the terminal, and the distribution station of a secondary system for improving the resistance against external interference and disturbances.

The planning of primary and secondary systems mentioned above involves not only the optimization of topological structure (e.g., power supply location, grid structure, communication structure, etc.) but also the selection of electrical and communication equipment, and power supply capacity optimization, etc. Furthermore, the operation conditions of various planning schemes need to be considered to evaluate a series of key indicators of the system, such as network loss, income, and renewable energy consumption rate, and then a double-layer optimization framework of operation planning can be obtained. The model solution block diagram is given in **Figure 4**.

Distribution network planning first needs to collect the load characteristics of the park and the diagram of the planning area, then implements spatial load forecasting. Primary system planning can be carried out including the location and capacity of substations and DG based on the results of spatial load forecasting. Then grid scheme planning is acquired by incorporating line equipment selection and path planning, which will be conveyed to power source planning for realizing

further optimization. Lastly, source-network collaborated planning of the primary system is formed via iterating the above process in limited times.

It is crucial to install the automatic terminal on the switchgear of the primary system based on source-network planning. Then, the communication topology optimization between each terminal needs to be carried out to build a run-plan collaborated model for the secondary system. The planning indexes of the secondary system are obtained through determined communication and automation schemes which will return to primary system planning. Hence, a multi-level planning model of the primary and secondary systems is formed, and the common control variables, constraints, and objective functions of each sub-model are shown in **Table 1**. The general mathematical model of cyber-physical fusion-based coordinated planning model can be expressed as follows:

$$\min c^I(x) + c^O(x, y) + c^R(z) \quad (1)$$

s.t.

$$x \in \{0, 1\}^n \quad (2)$$

$$f(x, y) \leq 0 \quad (3)$$

$$g(x, z) \leq 0 \quad (4)$$

where x represents the binary investment variables; y is continuous operating variables; z is the vector relating to topology and reliability. c^I is the investment cost; c^O is the operating cost; c^R is the reliability cost. $f(x, y)$ represents the set of constrained functions used to model the operation and planning of distribution systems; and $g(x, z)$ is a new set of constrained functions relating to reliability constraint.

Solution Algorithms

In the field of operation control optimization, there is a high demand for the efficiency of algorithms. For example, unit commitment (UC) and automatic generation control (AGC) (Zhang et al., 2018) require algorithms' solution time within the hour level, minute level, or even second level. The distribution network planning pays more attention to the quality of solution, i.e., obtaining a high-quality global optimal solution planning scheme in the possible shortest time.

TABLE 1 | Basic characteristics of the distribution network planning model.

Planning model	Primary system		Secondary system	
	Power source planning	Grid scheme planning	Automation system planning	Communication system planning
Control variable	Power location; power capacity; construction time	Line model; equipment model, cable trench; topology structure; construction time	Automation terminal type; automation terminal location; main station type; construction time	Topology; communication protocol; communication mode; construction time
Constraint condition	Investment constraints; power flow constraints; DG constraints (PV/WT/ESS/EV capacity constraints); reliability index constraints (SAIDI, SAIFI, ASAI, ENS); safety constraints (N-1 verification, short-circuit current verification, node voltage constraint, branch current constraint, injection power constraint)	Investment constraints; power flow constraints; DG constraints (PV/WT/ESS/EV capacity constraints); reliability index constraints (SAIDI, SAIFI, ASAI, ENS); safety constraints (N-1 verification, short-circuit current verification, node voltage constraint, branch current constraint, injected power constraint); operating topology constraint; connection mode constraint; guideline/standard constraint	Investment constraints; reliability index constraints (SAIDI, SAIFI, ASAI, ENS); technical constraints (terminal configuration quantity constraints); power supply range; guidelines/standard constraints	Investment constraints; reliability index constraints (SAIDI, SAIFI, ASAI, ENS); topology constraints (ring network structure); guidelines/standard constraints
Objective function	Investment cost; maintenance cost; operating cost (network loss, curtailment of wind and solar); DISCOs' income; carbon emissions; renewable energy consumption rate; power outage loss cost	Investment cost; maintenance cost; operating cost (network loss, curtailment of wind and solar); DISCOs' income; carbon emissions; renewable energy consumption rate; power loss cost; life cycle cost	Investment cost; maintenance cost; power outage loss; the number of switching operations; DISCOs' income; guideline/standard constraints; life cycle cost	Investment cost; maintenance cost; power outage loss; topology indicators (network invulnerability, robustness, connectivity, node influence, topology potential); communication delay

Each level of decision-making in the multi-level planning model of the primary and secondary system has its objective function and constraint conditions. Regarding the decision variables from the upper layer as parameters, the lower layer could search the optimal solutions of this layer based on objective function and constraints which are finally returned to the upper layer. The upper layer can find the overall optimal solution within the possible range according to the feedback from the lower layer. Hence, the multi-level planning problem is complicated and it is difficult to obtain solutions. Even the simplest two-level planning problem is also an NP-hard problem (Jerolow, 1985), as discussed in the literature on this subject (Blair, 1990; Bard, 1991).

Distribution network planning usually divides the planning cycle into several stages after considering load changes which increase the number of control variables and lead to dimensional disasters. Furthermore, the randomness of the DG and load side leads to vast uncertainties in the distribution system planning model. The uncertainty planning algorithms are then developed.

The main difficulty in high-reliability distribution network planning is that the reliability evaluation needs to consider topology search, which makes it difficult to acquire the explicit functional expression of the distribution network planning model and employ a convex optimization method to solve it. Therefore, it is necessary to simplify the reliability assessment appropriately according to the actual planning model.

Taking the primary grid scheme planning of the distribution network as an example, the number of feeders in the county can be reached by more than one hundred. Distribution network planning is a large-scale discrete and non-convex complex optimization problem in essence, and the commonly solved algorithms are classical mathematical methods and intelligent

algorithms. After transforming the unsolved problem into the convex optimization problem, classical mathematical methods can be adopted to solve the global optimal solution. However, this method is hard to converge by high-dimensional non-convex problems. Intelligent algorithms have low dependence on models, but they generally have defects such as slow convergence speed, complex parameter settings, and falling into local optimum. In consequence, combining the above methods to form an effective hybrid algorithm is a valuable research direction.

COORDINATED PLANNING OF PRIMARY AND SECONDARY SYSTEM

The 24th International Power Supply Conference points out that the coordinated planning of the primary system and ICT system is key to improving the reliability of the distribution network which is worthy of attention.

Reliability Evaluation Algorithms

Although primary and secondary systems are coupled with each other, information equipment has an uninterrupted power supply that exerts little influence on the system. Hence, the reliability evaluation is mainly from the perspective of a physical system.

The factors that affect the reliability of the physical system by the cyber system include network equipment, network topology, communication mode, communication protocol, and communication distance, etc. Successful information transmission requires that the equipment components of the information link are in normal working conditions. A network component may exist in multiple information links at the same time, so failure will affect the

reliability of multiple information links. The transmission performance of communication links is influenced by the following aspects: the connectivity affected by a network node and transmission channel failure, the timeliness affected by message transmission delay, and the accuracy affected by transmission errors (Haghighat and Zeng, 2016).

The impact of a cyber system on the physical system is manifested as whether the physical element can correctly realize its function. Therefore, the reliability evaluation of the cyber-physical system can be described by the working state of physical elements. According to the failure type of cyber system, the interaction of cyber-physical system can be divided into direct impact and indirect impact. In detail, the former includes the direct impact of information components and cyber systems on physical components, while the indirect impact measures the influence on physical components such as power generation equipment via enumerating and merging the possible states of the cyber system (Falahati et al., 2012; Falahati and Fu, 2014). The components according to IEC 61850 standard in the cyber system have three levels, i.e., process layer, interval layer, and management layer. It is of great significance to analyze the random failure of information elements for improving the stability of the microgrid system (Lei et al., 2014; Liu et al., 2020).

With the development of information technologies and power markets, the influence of human factors such as cyber-attack should be considered. CPS carries out vulnerability assessment under the joint attack of man-made physical and information (Sridhar et al., 2011; Li et al., 2016), which extends the concept of operational reliability to the cyber system (Davis et al., 2015; Xin et al., 2015). It is valuable to analyze the reliability of the distribution network when the communication network fails, considering the influence of network communication facilities, as well as the arrangement of synchronous switches and fault monitors (Mohammadi et al., 2019).

Traditional reliability indicators are unable to describe the coupling relationship of cyber-physical systems. Hence, some novel indexes are presented. The concept of information entropy is introduced to the physical system based on the operational control of the cyber system. The disordered state of physical nodes is denoted through energy entropy to evaluate the reliability of the microgrid CPS (Munoz et al., 2018). In terms of system indicators, the generalized system average outage frequency index, the generalized system average outage duration index, the generalized power shortage expectation index, and the generalized power supply availability index are proposed, combining the influence of information components on system failure (Wang et al., 2019). To evaluate the impact of cyber-physical systems after cyber-attacks, a set of elastic index evaluation models are also established (Clark and Zonouz, 2019).

In recent years, some scholars have overcome the problem that the original reliability evaluation algorithms require topological search and cannot be expressed explicitly. Literature on this subject (Munoz et al., 2018) establishes an explicit calculation formula for the reliability evaluation of the distribution network that has successfully been applied to DSEP. However, this method is only suitable for specific grid frames. Furthermore, a study

(Jooshaki et al., 2019) proposes a linearized explicit function expression, which can greatly improve the solution efficiency of distribution network planning with satisfactory accuracy. Recently, another study (Li et al., 2020a) proposes a mixed integer linearized programming formulation of mesh distribution networks and applied this model in the distribution network planning model successfully in Li et al. (2020b) and Li et al. (2021). Note that there are a few works that focus on establishing explicit functional expressions for evaluating the reliability of primary and secondary systems, a promising research field.

Coordinated Planning Methods

CPS often has four levels, namely backbone network, access network, an interface layer, and physical domain. The control instructions of the secondary system determine the operating status of the primary system. Moreover, the grid status will influence the input of the cyber system and provide an energy guarantee.

In another study Yang et al. (2017), a double-level planning model is used to optimize the capacity, communication terminal location, and communication topology of the energy storage system. Reference Harri et al. (2019) designs the collaborated optimization of DG, charging pile, and protection equipment in a smart grid, and an intelligent optimization algorithm is adopted to solve the complex collaborated planning model. Another work (Heidari et al., 2018) develops a reliability analysis algorithm, considering the influence of interaction between primary and secondary systems on the reliability of CPS. Meanwhile, the genetic algorithm (GA) is used to optimize the fault indicator and switch position in this paper. As outlined in other literature, a study Mohammadi et al. (2019) has employed GA to realize high-reliability planning for control equipment and protection equipment in the distribution network. Moreover, other studies Heidari et al. (2017) have built a collaborated planning model of the primary network and secondary terminal equipment based on the reliability index constraints from the perspective of DISCO, which are solved by GA.

CONCLUSION

This paper summarizes the key difficulties of high-reliability primary and secondary system coordinated planning, such as reliability evaluation algorithms, coordinated models, and solution algorithms, etc. Then, two hot research directions in distribution network modeling are classified, i.e., the complex network frame and its optimization. It also describes some achievements of primary and secondary system coordinated planning.

The essence of primary and secondary system coordinated planning is a large-scale non-convex and non-linear planning problem with multi-variable, multi-stages, and multi-objectives. Furthermore, there are still some obstacles in applying primary and secondary coordinated planning to practical engineering problems, which can be discussed as follows:

- (1) Academician Xue in the Chinese Academy of Science first proposed the concept of CPSS in 2017, which is a power system considering market game mechanism, environmental science, economic policy, and other human factors (Yu and Xue, 2016; Xue and Yu, 2017). It is necessary to further study the influence of market mechanisms and environmental factors on distribution network models based on primary and secondary system coordinated planning. The introduction of market mechanisms will inevitably bring more uncertainties that increase the difficulty of modeling.
- (2) The optimization methods in cyber-physical system planning are mainly classic mathematical optimization methods and intelligent optimization algorithms. The former converts a mathematical model into a convex optimization problem to obtain the global optimal solution. While the latter does not rely on a specific mathematical model, but easily traps at a local optimum. The actual distribution network planning model often includes large-scale nodes, as well as multi-variable, multi-time, and multi-stage optimization. It is an effective way to combine classical mathematical methods and intelligent optimization algorithms to establish a stronger hybrid algorithm for solving the aforementioned complicated planning model.
- (3) The development of emerging technologies such as cloud computing, the ubiquitous internet of things (IoT), and big data has promoted the integration of primary and secondary

systems. However, most of the above concepts and theories still stay at the level of simulation computing. The efficient smart grid CPS test platform needs to be further explored to test, evaluate, and verify the feasibility of these novel theories.

DATA AVAILABILITY STATEMENT

The original contributions presented in the study are included in the article/Supplementary Material, further inquiries can be directed to the corresponding author.

AUTHOR CONTRIBUTIONS

CG: conceptualization, methodology, and writing—original draft. TW, HC and RC: formal analysis, visualization, and resources. ZW and TY: writing—review, and editing.

FUNDING

The authors gratefully acknowledge the support of the Science and technology project of China Southern Power Grid Corporation (GDKJXM20173256)

REFERENCES

- Bard, J. F. (1991). Some Properties of the Bilevel Programming Problem. *J. Optim. Theor. Appl.* 68 (2), 371–378. doi:10.1007/bf00941574
- Blair, B. A. E. (1990). Computational Difficulties of Bilevel Linear Programming. *Operations Res.* 38 (3), 556–560. doi:10.1287/opre.38.3.556
- Cai, Z., Yu, M., Steurer, M., and Ng, J. (2019). A New Grouping Protocol for Smart Grids. *IEEE Trans. Smart Grid* 10 (1), 955–966. doi:10.1109/tsg.2017.2756863
- Clark, A., and Zonouz, S. (2019). Cyber-physical Resilience: Definition and Assessment Metric. *IEEE Trans. Smart Grid* 10 (2), 1671–1684. doi:10.1109/tsg.2017.2776279
- Colak, I., Sagiroglu, S., Fulli, G., Yesilbudak, M., and Covrig, C.-F. (2016). A Survey on the Critical Issues in Smart Grid Technologies. *Renew. Sustainable Energ. Rev.* 54, 396–405. doi:10.1016/j.rser.2015.10.036
- Cortes, C. A., Contreras, S. F., and Shahidehpour, M. (2017). Microgrid Topology Planning for Enhancing the Reliability of Active Distribution Networks. *IEEE Trans. Smart Grid* 9 (6), 6369–6377. doi:10.1109/tsg.2017.2709699
- Davis, K. R., Davis, C. M., Zonouz, S. A., Bobba, R. B., Berthier, R., Garcia, L., et al. (2015). A Cyber-Physical Modeling and Assessment Framework for Power Grid Infrastructures. *IEEE Trans. Smart Grid* 6 (5), 2464–2475. doi:10.1109/tsg.2015.2424155
- Dileep, G. (2020). A Survey on Smart Grid Technologies and Applications. *Renew. Energ.* 146 (2), 2589–2625. doi:10.1016/j.renene.2019.08.092
- Esmaeeli, M., Kazemi, A., Shayanfar, H., Chicco, G., and Siano, P. (2017). Risk-based Planning of the Distribution Network Structure Considering Uncertainties in Demand and Cost of Energy. *Energy* 119, 578–587. doi:10.1016/j.energy.2016.11.021
- Falahati, B., and Fu, Y. (2014). Reliability Assessment of Smart Grids Considering Indirect Cyber-Power Interdependencies. *IEEE Trans. Smart Grid* 5 (4), 1677–1685. doi:10.1109/tsg.2014.2310742
- Falahati, B., Fu, Y., and Wu, L. (2012). Reliability Assessment of Smart Grid Considering Direct Cyber-Power Interdependencies. *IEEE Trans. Smart Grid* 3 (3), 1515–1524. doi:10.1109/tsg.2012.2194520
- Farwell, J. P., and Rohozinski, R. (2011). Stuxnet and the Future of Cyber War. *Survival* 53 (1), 23–40. doi:10.1080/00396338.2011.555586
- Georgilakis, P. S., and Hatziargyriou, N. D. (2015). A Review of Power Distribution Planning in the Modern Power Systems Era: Models, Methods and Future Research. *Electric Power Syst. Res.* 121, 89–100. doi:10.1016/j.epsr.2014.12.010
- Gholizadeh, R. R., Najafi, R. S., and Hosseinian, S. H. (2018). A Framework for Optimal Coordinated Primary-Secondary Planning of Distribution Systems Considering MV Distributed Generation. *IEEE Trans. Smart Grid* 9 (2), 1408–1415. doi:10.1109/tsg.2016.2590425
- Haghighat, H., and Zeng, B. (2016). Distribution System Reconfiguration under Uncertain Load and Renewable Generation. *IEEE Trans. Power Syst.* 31 (4), 2666–2675. doi:10.1109/tpwrs.2015.2481508
- Harri, A. M., Hejazi, M., and Hashemi, D. H. (2019). Reliability Optimization of Smart Grid Based on Optimal Allocation of Protective Devices, Distributed Energy Resources, and Electric Vehicle/plug-In Hybrid Electric Vehicle Charging Stations. *J. Power Sourc.* 436, 226824. doi:10.1016/j.jpowsour.2019.226824
- Heidari, K. M., Sepehry, M., and Aravinthan, V. (2018). Fault Detector and Switch Placement in Cyber-Enabled Power Distribution Network. *IEEE Trans. Smart Grid* 9 (2), 980–992. doi:10.1109/tsg.2016.2573261
- Heidari, S., and Fotuhi-Firuzabad, M. (2019). Integrated Planning for Distribution Automation and Network Capacity Expansion. *IEEE Trans. Smart Grid* 10 (4), 4279–4288. doi:10.1109/tsg.2018.2855218
- Heidari, S., Fotuhi-Firuzabad, M., and Lehtonen, M. (2017). Planning to Equip the Power Distribution Networks with Automation System. *IEEE Trans. Power Syst.* 32 (5), 3451–3460. doi:10.1109/tpwrs.2017.2650210
- Humayed, A., Lin, J., Li, F., and Luo, B. (2017). Cyber-physical Systems Security-A Survey. *IEEE Internet Things J.* 4 (6), 1802–1831. doi:10.1109/jiot.2017.2703172
- Jeroslow, R. G. (1985). The Polynomial Hierarchy and a Simple Model for Competitive Analysis. *Math. Programming* 32 (2), 146–164. doi:10.1007/bf01586088
- Jooshaki, M., Abbaspour, A., Fotuhi-Firuzabad, M., Farzin, H., Moeini-Aghtaie, M., and Lehtonen, M. (2019). A MILP Model for Incorporating Reliability Indices in Distribution System Expansion Planning. *IEEE Trans. Power Syst.* 34 (3), 2453–2456. doi:10.1109/tpwrs.2019.2892625

- Lei, H., Singh, C., and Sprintson, A. (2014). Reliability Modeling and Analysis of IEC 61850 Based Substation protection Systems. *IEEE Trans. Smart Grid* 5 (5), 2194–2202. doi:10.1109/tsg.2014.2314616
- Li, Z., Shahidehpour, M., Alabdulwahab, A., and Abusorrah, A. (2016). Bilevel Model for Analyzing Coordinated Cyber-Physical Attacks on Power Systems. *IEEE Trans. Smart Grid* 7 (5), 2260–2272. doi:10.1109/tsg.2015.2456107
- Li, Z., Wu, W., Tai, X., and Zhang, B. (2021). A Reliability-Constrained Expansion Planning Model for Mesh Distribution Networks. *IEEE Trans. Power Syst.* 36 (2), 948–960. doi:10.1109/tpwrs.2020.3015061
- Li, Z., Wu, W., Tai, X., and Zhang, B. (2020). Optimization Model-Based Reliability Assessment for Distribution Networks Considering Detailed Placement of Circuit Breakers and Switches. *IEEE Trans. Power Syst.*, 35 (9), 3991–4004. doi:10.1109/tpwrs.2020.29815085
- Li, Z., Wu, W., Zhang, B., and Tai, X. (2020). Analytical Reliability Assessment Method for Complex Distribution Networks Considering post-fault Network Reconfiguration. *IEEE Trans. Power Syst.* 35 (2), 1457–1467. doi:10.1109/tpwrs.2019.2936543
- Liang, G., Weller, S. R., Zhao, J., Luo, F., and Dong, Z. Y. (2017). The 2015 Ukraine Blackout: Implications for False Data Injection Attacks. *IEEE Trans. Power Syst.* 32 (4), 3317–3318. doi:10.1109/tpwrs.2016.2631891
- Lin, Z., Hu, Z., and Song, Y. (2019). Distribution Network Expansion Planning Considering \$N-1\$ Criterion. *IEEE Trans. Power Syst.* 34 (3), 2476–2478. doi:10.1109/tpwrs.2019.2896841
- Liu, W., Gong, Q., Han, H., Wang, Z., and Wang, L. (2018). Reliability Modeling and Evaluation of Active Cyber Physical Distribution System. *IEEE Trans. Power Syst.* 33 (6), 7096–7108. doi:10.1109/tpwrs.2018.2854642
- Liu, W., Lin, Z., Wang, L., Wang, Z., Wang, H., and Gong, Q. (2020). Analytical Reliability Evaluation of Active Distribution Systems Considering Information Link Failures. *IEEE Trans. Power Syst.* 35 (6), 4167–4179. doi:10.1109/tpwrs.2020.2995180
- Lotfi, H., and Khodaei, A. (2017). AC versus DC Microgrid Planning. *IEEE Trans. Smart Grid* 8 (1), 296–304. doi:10.1109/tsg.2015.2457910
- Mohammadi, A., Soleymani, S., and Mozafari, B. (2019). A Stochastic Formulation for Distribution Automation Planning Incorporating Emergency Demand Response Programs. *Int. Trans. Electr. Energy Syst.*, 29(12):e12138. doi:10.1002/2050-7038.12138
- Munoz, D. G., Contreras, J., and Arroyo, J. (2018). Distribution Network Expansion Planning with an Explicit Formulation for Reliability Assessment. *IEEE Trans. Power Syst.* 33 (3), 2583–2596. doi:10.1109/tpwrs.2017.2764331
- Popovic, Z. N., Knezevic, S. D., and Kerleta, V. D. (2019). Network Automation Planning in Distribution Networks with Distributed Generators Using a Risk-Based Approach. *Electr. Eng.* 101 (2), 659–673. doi:10.1007/s00202-019-00814-9
- Sridhar, S., Hahn, A., and Govindarasu, M. (2011). Cyber-physical System Security for the Electric Power Grid. *Proc. IEEE* 100 (1), 210–224.
- Sun, L. M., and Yang, B. (2020). Nonlinear Robust Fractional-Order Control of Battery/SMES Hybrid Energy Storage Systems. *Power Syst. Prot. Control.* 48 (22), 76–83. doi:10.19783/j.cnki.pspc.191598
- Tuballa, M. L., and Abundo, M. L. (2016). A Review of the Development of Smart Grid Technologies. *Renew. Sustainable Energ. Rev.* 59, 710–725. doi:10.1016/j.rser.2016.01.011
- Wang, Z. G., Chen, Y. R., and Ceng, J. (2019). Modeling and Reliability Assessment of Completely Distributed Microgrid Cyber Physical System. *Power Syst. Tech.* 43 (7), 2413–2421.
- Xin, S., Guo, Q., Sun, H., Zhang, B., Wang, J., and Chen, C. (2015). Cyber-physical Modeling and Cyber-Contingency Assessment of Hierarchical Control Systems. *IEEE Trans. Smart Grid* 6 (5), 2375–2385. doi:10.1109/tsg.2014.2387381
- Xue, Y., and Yu, X. (2017). Beyond Smart Grid-Cyber-Physical-Social System in Energy Future [point of View]. *Proc. IEEE* 105 (12), 2290–2292. doi:10.1109/jproc.2017.2768698
- Yang, T., Huang, Z., Pen, H., and Zhang, Y. (2017). Optimal Planning of Communication System of CPS for Distribution Network. *J. Sensors* 2017, 1–10. doi:10.1155/2017/9303989
- Yu, X., and Xue, Y. (2016). Smart Grids: A Cyber-Physical Systems Perspective. *Proc. IEEE* 104 (5), 1058–1070. doi:10.1109/jproc.2015.2503119
- Zhang, X. S., Li, Q., and Yu, T. (2018). Consensus Transfer Q-Learning for Decentralized Generation Command Dispatch Based on Virtual Generation Tribe. *IEEE Trans. Smart Grid* 9 (3), 2152–2165. doi:10.1109/tsg.2016.2607801

Conflict of Interest: CG, TW, HC and RC were employed by the company Guangdong Power Grid Co., Ltd.

The remaining authors declare that the research was conducted in the absence of any commercial or financial relationships that could be construed as a potential conflict of interest.

Copyright © 2021 Gao, Wang, Cao, Wang, Yu and Cheng. This is an open-access article distributed under the terms of the Creative Commons Attribution License (CC BY). The use, distribution or reproduction in other forums is permitted, provided the original author(s) and the copyright owner(s) are credited and that the original publication in this journal is cited, in accordance with accepted academic practice. No use, distribution or reproduction is permitted which does not comply with these terms.

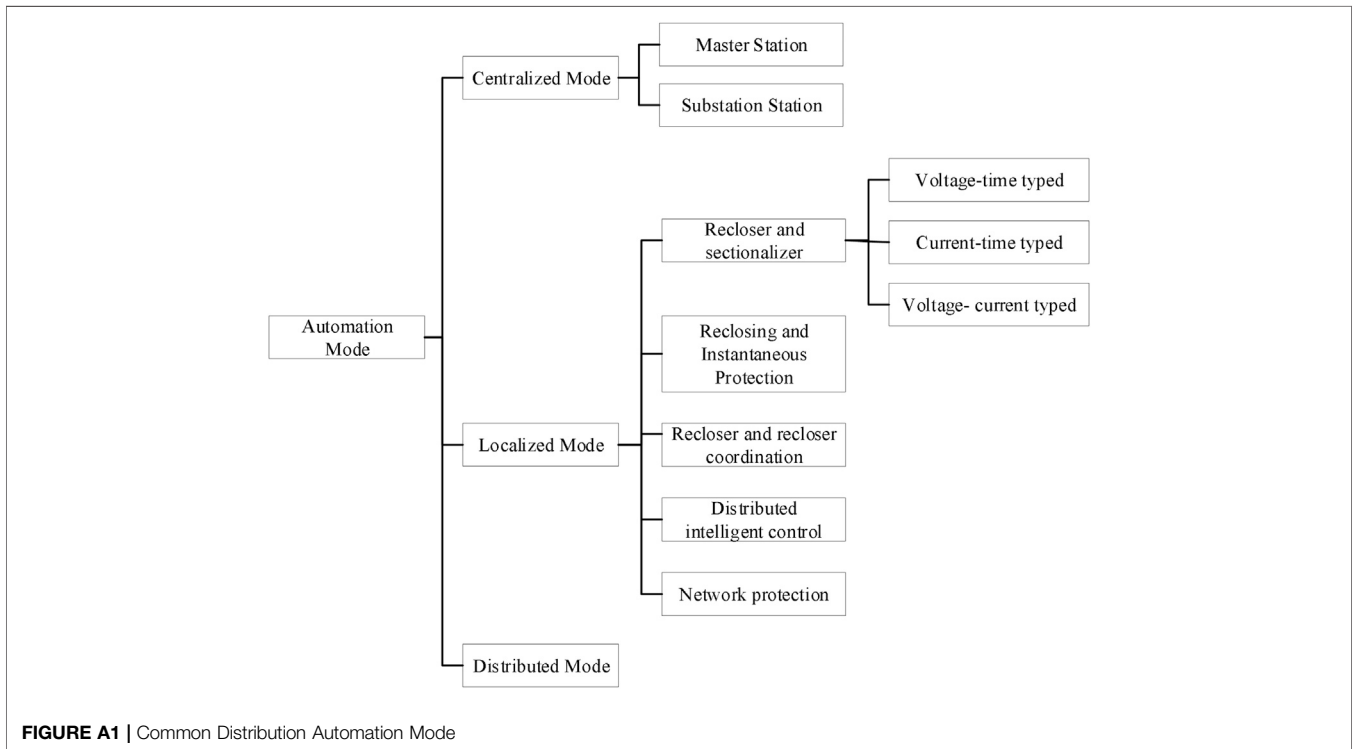
APPENDIX A

APPENDIX B

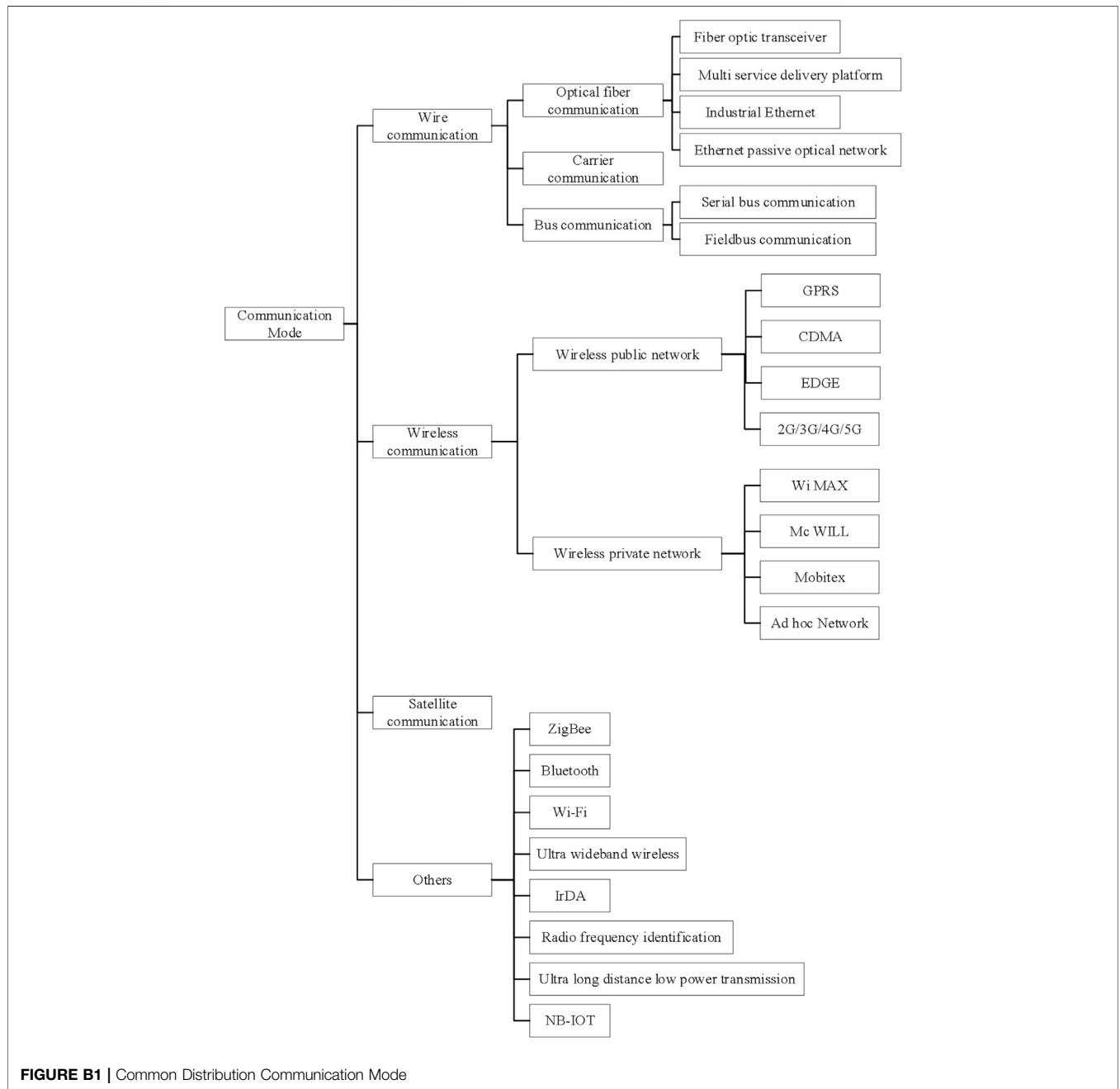

FIGURE B1 | Common Distribution Communication Mode