



A Survey on Integrated Access and Backhaul Networks

Yongqiang Zhang, Mustafa A. Kishk* and Mohamed-Slim Alouini

Computer, Electrical and Mathematical Sciences and Engineering Division, King Abdullah University of Science and Technology, Thuwal, Saudi Arabia

Benefiting from the usage of the high-frequency band, utilizing part of the large available bandwidth for wireless backhauling is feasible without considerable performance sacrifice. In this context, integrated access and backhaul (IAB) has been proposed by the Third Generation Partnership Project (3GPP) to reduce the expenses related to the deployment of fiber optics for 5G and beyond networks. In this paper, first, a brief introduction of IAB based on the 3GPP release is presented. Then, the existing research on IAB networks based on 3GPP specifications and possible non-3GPP research extensions are surveyed. The research on non-3GPP extensions includes the integration of IAB networks with other advanced techniques beyond the currently defined protocol stacks, such as the integration of IAB to cache-enabled, optical communication transport, and non-terrestrial networks. Finally, the challenges and opportunities related to the development and commercialization of the IAB networks are discussed.

OPEN ACCESS

Edited by:

Michele Polese,
Northeastern University, United States

Reviewed by:

Thang X. Vu,
University of Luxembourg,
Luxembourg
Monir Hossen,
Khulna University of Engineering &
Technology, Bangladesh

*Correspondence:

Mustafa A. Kishk
mustafa.kishk@kaust.edu.sa

Specialty section:

This article was submitted to
Wireless Communications,
a section of the journal
Frontiers in Communications and
Networks

Received: 29 December 2020

Accepted: 29 March 2021

Published: 01 June 2021

Citation:

Zhang Y, Kishk MA and Alouini M-S
(2021) A Survey on Integrated Access
and Backhaul Networks.
Front. Comms. Net. 2:647284.
doi: 10.3389/frcmn.2021.647284

Keywords: wireless and cellular networks, backhaul, wireleb communication, wireless and mobile technology, communication channel

1. INTRODUCTION

Due to the dramatic growth in both the end-users population (e.g., smartphones and tablets) and demand for information service (e.g., video streaming and cloud computing), global mobile data traffic has skyrocketed in recent years (Soldani and Manzalini, 2015). By 2030, the global mobile data traffic volume is predicted to increase 670 times compared with 2010 (Union, 2015). In order to deal with such exponential traffic growth, the density of base stations (BSs) is expected to substantially increase in the future. The feasibility of denser BSs deployments (a.k.a., Network densification) was discussed in (Bhushan et al., 2014) with the anticipated requirement of coping with the increasing traffic growth. As a promising approach for extending the cell area and meeting the high capacity demand, network densification is aiming to provide a reliable access channel by reducing the distance from mobile users to BSs and increasing the spectrum reuse (Agiwal et al., 2016).

However, in conventional network densification, one of the major drawbacks is the capital/operational cost of the optical fiber deployment for BSs. For instance, one-meter optical fiber deployment is estimated to cost approximately 100 – 200 USD in a downtown area, nearly 85% of the total expense results from the trenching and installing of operations (Willebrand and Ghuman, 2001). In this context, there is an attractive implementation solution by using wireless backhaul instead of conventional wired-optical-fiber backhaul. Compared with wired-fiber backhaul, wireless backhaul can not only provide almost the same transmitting rate as optical fiber but also bring considerable cost decline and more flexible/timely deployment (e.g., no intrusion) (Teyeb et al., 2019; Czeglédi et al., 2020).

On the other hand, one of the objectives of 6G communications is to achieve worldwide connectivity (Dang et al., 2020). To this end, there is an emerging need for providing reliable communications service in remote and rural areas. For the same reasons, it might be economically appealing to use wireless backhaul rather than wired-optical-fiber backhaul to provide connectivity in such underserved areas.

In Long-Term Evolution (LTE) Rel-10, 3GPP first introduced the study item involving wireless backhaul, known as LTE relaying (3GPP, 2016). However, since spectrum resource in LTE is too valuable to be used for backhauling, it gained little commercial interest. As several nationwide 5G mobile networks have been already launched, many authorities from various countries have announced plans to grant 5G licenses for commercial use. One of the key features of 5G is the usage of high frequencies transmitting carriers [e.g., millimeter wave (mmWave)], with the aim to facilitate the prospective larger spectrum. The large available spectrum of the these bands empowers a dramatic improvement in transmission data rates, which support carrier frequencies of up to 52.6 GHz in mmWave (Rangan et al., 2014). Consequently, limited by physical properties, high-frequency carriers lead to limited coverage area and need for higher density of BSs deployment.

The 5G new radio (NR) has been under development by 3GPP over the past few years, to meet the demands of higher system capacity, better coverage, and higher data rates (Parkvall et al., 2017). Key design principles in 5G NR consist of ultra-lean transmission, advanced antenna technologies, and spectrum flexibility including operation in high-frequency bands (Lin et al., 2019). Benefiting from the wide bandwidth in 5G NR, operator is capable of partitioning the total radio resource into two parts for wireless backhauling and access, respectively. This technique is known as integrated access and backhaul (IAB) networks, which has recently attracted a lot of research attention (Dehos et al., 2014; Teyeb et al., 2019; Madapatha et al., 2020). For 5G NR, IAB has already been standardized and recognized as a cost-effective alternative to the wired backhauling (3GPP, 2020a). Compared to the LTE relaying, IAB NR networks have more potential to receive considerable industrial attention (Makki et al., 2019; Wang and Li, 2019; Baker and Poikselkä, 2020; Ericsson, 2020a). For example, in the case of mmWave network, the shortage of narrow coverage will result in an urgent need to increase the density of BSs deployment. Consequently, there is a much higher demand for wireless backhauling. Meanwhile, by exploiting the much larger bandwidth, it is less expensive for operators to perform self-backhauling. Besides, a large number of antennas can easily be employed for mmWave-enabled BSs due to their small wavelength, which can enhance the signal directional gain and link reliability for backhauling.

Due to the increasing interest from both academia and industry, it is required to have a comprehensive overview of IAB networks for beginners in the related research field. In comparison to the vast amount of published work in the IAB networks, to the best of our knowledge, there is no survey that attempts to summarize the existing literature, which motivates this work. As shown in **Figure 1**, the rest of the paper is organized as follows. In section 2, we give a brief introduction

of IAB architecture. The stochastic geometry-based analysis for IAB network is discussed in section 3. sections 4, 5 focus on the resource allocation and scheduling research in IAB network. Studies on the integration of IAB network with cache-enabled network, optical communication, and non-terrestrial communication are surveyed in section 6. Section 7 and section 8, respectively. The challenges and opportunities of IAB are discussed in section 9. The paper is concluded in section 10.

2. INTEGRATED ACCESS AND BACKHAUL TECHNIQUE

Over the course of the last 20 years, wireless backhauling in wireless networks has been studied extensively (Raza, 2011). However, there is no tight integration of access and backhaul in the studies of LTE backhaul networks, because only one single hop with a fixed parent BS is supportable for LTE relay, and strict resource partitioning is specified between access and backhaul (Polese et al., 2020). In contrast, the IAB network offers a more flexible deployment solution without the heavy overhead of optical-fiber installation (Dahlman et al., 2020). Based on a wired connection to the core network, the IAB donor can provide communication access to mobile users and wireless backhaul to IAB nodes. IAB nodes are able to wirelessly provide network service access to the mobile user as well as the backhaul traffic. Therefore, IAB nodes can be regarded as a wireless relays for extending the coverage of an IAB donor. This functionality is helpful for networks to achieve robust coverage performance when line-of-sight (LoS) propagation is blocked by environmental obstacles, such as buildings. **Figure 2** provides a simple example of an IAB network, where R_{AL} and R_{BH} denote the data rates of the wireless access link and the wireless backhaul link. The achievable data rate from the mobile user to the IAB donor is determined by the minimum rate of the access link and the backhaul link. For example, in **Figure 2**, the transmission rate from the mobile user 1 to the IAB donor is $\min\{R_{AL,1}, R_{BH,1}, R_{BH,2}\}$.

2.1. New Radio IAB Architecture

With the objective to cope with the increasing demand for backhaul, 3GPP first proposed a study item on IAB in 3GPP (2018). The physical-layer specification of IAB was completed at 2019, and higher-layer protocols and architecture were completed in 3GPP Rel-16 at July 2020 (3GPP, 2020a). Further enhancements (e.g., mobile IAB) have been carried out in 3GPP Rel-17, which is expected to be frozen in December 2020. We will give a brief overview of the IAB NR in the following sections based on 3GPP specifications.

Figures 3, 4 illustrate the IAB protocol stack for user plane and control plane, respectively (3GPP, 2020a). The overall architecture is based on the functionality split. In particular, the IAB donor consists of a central unit (CU) and no less than one distributed unit (DU). The DU includes the Radio Link Control (RLC), Medium Access Control (MAC), and Physical layer (PHY) protocols. Apart from Packet Data Convergence Protocol (PDCP), the CU includes Service Data Adaptation Protocol

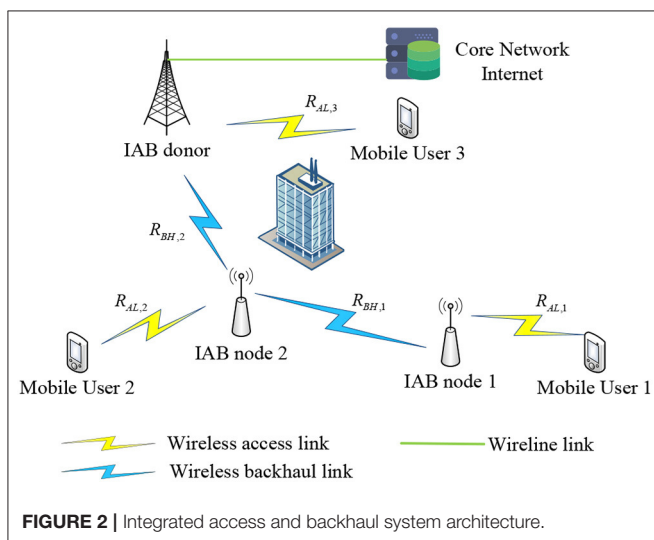
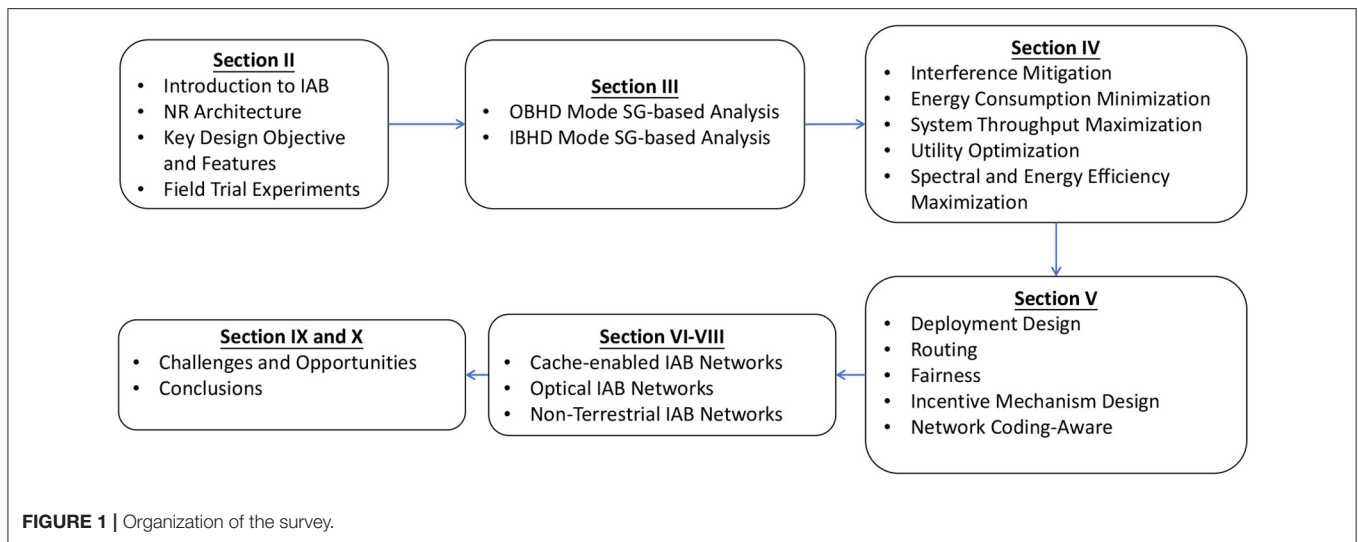

(SDAP) or Radio Resource Control (RRC) protocol in the control plane or user plane, respectively. The interface between CU and DU is standardized as F1 interface, which defines the higher layer protocols. The IAB donor connects the core network *via* non-IAB backhaul and uses the IAB donor-DU wirelessly to serve UEs and the connected IAB nodes.

IAB nodes comprise mobile terminations (MTs) and DU functionalities. The IAB nodes rely on IAB for backhauling and provide service for UEs and IAB nodes *via* the DU functionality. The MTs act as normal devices and associate with the DU of the parent IAB node or IAB donor. The message transmission is based on the lower layer functionality provided by the link between the IAB node MT and its parent node DU. Besides, IAB node can be backhauled to the IAB donor through more than one intermediate IAB node, implying that multi-hop backhauling is supported in the IAB network.

The lower three protocol stack up to the RLC are known collectively as the NR-Uu interface. The middle three layers between Backhaul Adaptation Protocol (BAP) and PDCP provide the F1 interface for user plane (F1-U) and control plane (F1-C).

The BAP is a novel protocol defined by IAB, and is responsible for routing information packets from IAB donor to the target IAB node and vice versa. A typical IAB node has its own BAP address. For downlink (DL) scenario, the BAP layer of IAB donor first adds the BAP header to the information packets. The BAP header comprises the routing ID for the destination BAP address, and the path ID includes the path to the destination node. In addition, a flag indicator included in the BAP header is determined by the packet type (i.e., control plane or user plane).

Once the typical IAB node receives an information packet, the BAP layer will first check the routing ID in the BAP header. If the IAB node is the destination node, the information packet will be forwarded to higher layers. For example, the packet will be elevated to GTP-U or F1-AP when it is intended for UE served by the IAB node or it is a control plane packet for the IAB node. Otherwise, the IAB node will deliver the packet to its DU and transmit the packet to the next node based on the routing table.

2.2. Key Design Objective and Features

The advantage of IAB lies in its supporting flexible and high-density deployments of NR cells without relying on the costly wired backhaul network deployment. In addition, IAB is equipped for a diverse range of deployment scenarios, including outdoor or indoor dense small-cell deployments and coverage extension.

2.2.1. Spectrum

Benefiting from the large bandwidth and small wavelength, mmWave IAB enables massive beamforming and using a portion of the inexpensive bandwidth to do the backhaul. Since high-band spectrum is generally organized as an unpaired spectrum, for operational purposes, 3GPP proposed that IAB enables wireless in-band and out-of-band relaying.

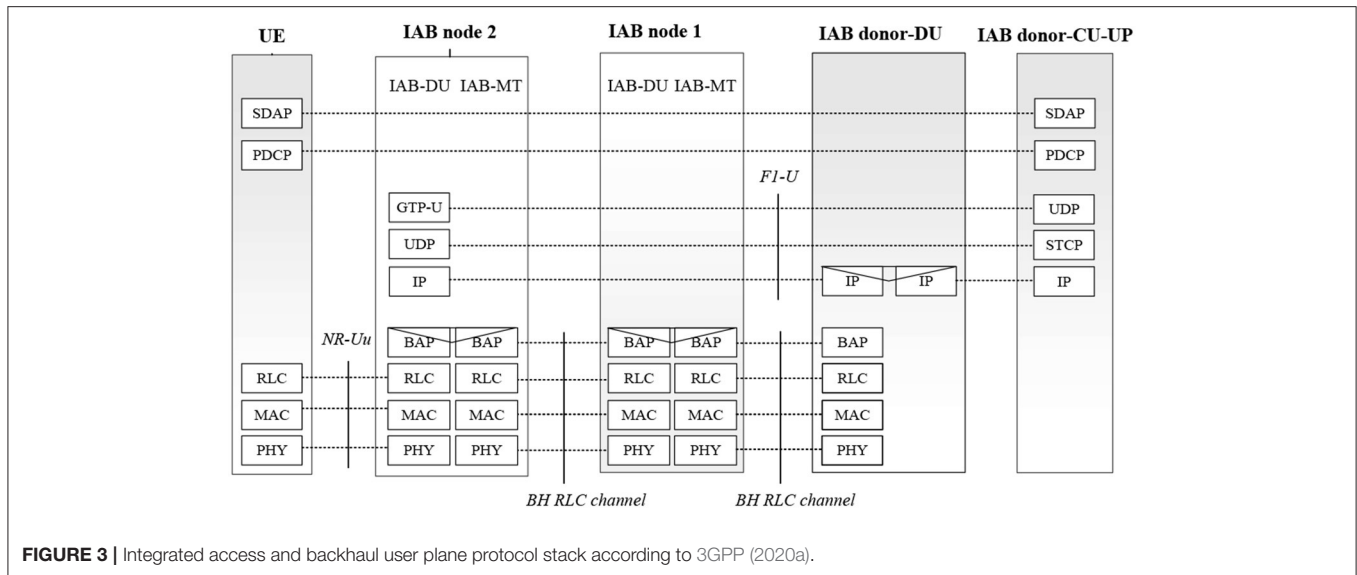

FIGURE 3 | Integrated access and backhaul user plane protocol stack according to 3GPP (2020a).

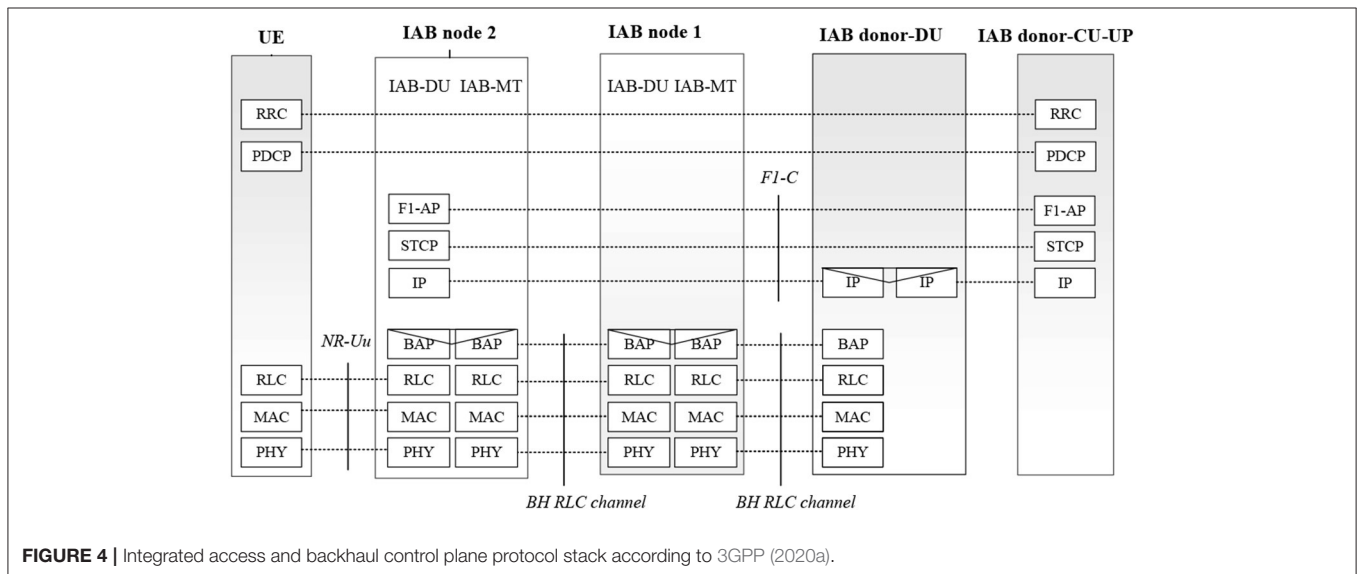

FIGURE 4 | Integrated access and backhaul control plane protocol stack according to 3GPP (2020a).

- In-band relaying: Both access and backhaul links are simultaneously transmitted at the same frequency band.
- Out-of-band relaying: The access link and backhaul link transmissions are conducted in orthogonal channels. That is, the access link transmission is conducted at a certain frequency band, and the backhaul link utilizes the remaining frequency band.

2.2.2. Network Topology

Integrated access and backhaul enables multi-hop backhauling, affording a flexible range extension (Teyeb et al., 2019). In Rel-16, directed acyclic graph (DAG) based and spanning tree (ST) based multi-hop topologies are supported. The end-to-end performance of IAB networks is strongly affected by the number of hops, the maximal number of relays that the IAB donor can support, and route selection (Polese et al., 2018). As shown in (Polese et al., 2018; Yuan et al., 2018; Gupta et al.,

2019), with proper design of the route selection, IAB networks can utilize the advantage of multi-hop backhaul to improve the bottleneck performance. Furthermore, network topology adaptation and redundant connectivity are supported in IAB, enabling better backhaul performance and fast adaptation to handle link overloads or failures.

2.2.3. Radio Link

With the sharing of resources between access and backhaul, it may result in limitations on the end-user quality of service (QoS) (e.g., rate and latency) and new interference results from the access/backhaul-to-backhaul/access needed mitigation. One of the targets in radio link design is to ensure that the QoS requirements of users are fulfilled even in a multi-hop setting. Another important issue is that the deployment of IAB network should be transparent to UEs (i.e., no additional requirement for UE features/standardization).

2.3. Field Trial Experiments

The advantage of mmWave IAB network was verified by a field experiment in (Tian et al., 2019). For instance, in (Tian et al., 2019), coverage ratio and user throughput in an outdoor IAB network with time-division multiplexing were investigated. Their simulation results showed that compared to when an IAB node is not deployed, the coverage ratio can be improved to approximately 78%–89% with the deployment of only one IAB, and that a maximum coverage ratio gain of 46% can be achieved. The system throughput improved significantly by IAB node deployment, compared with non-IAB node deployment, up to 81.5% throughput gain is obtained. Since the wireless backhaul enables network densification without incurring additional fiber deployment, compared with wired optical fiber based backhaul, IAB can reduce a large portion of the total deployment cost tied to trenching and installation (Teyeb et al., 2019). Moreover, IAB allows network operators to deploy small-cell BSs (SBSs) flexibly, which does not need digging or disruption of infrastructure (Ericsson, 2020b).

3. STOCHASTIC GEOMETRY-BASED ANALYSIS OF IAB NETWORKS

Stochastic geometry (SG) has been regarded as a powerful mathematical tool for modeling, analyzing, and designing wireless network (ElSawy et al., 2013). In this section, we will introduce some papers with the integration of SG and IAB network.

3.1. Out-of-Band HD (OBHD) Mode

Singh et al. (2015) developed a tractable mmWave IAB network analysis model, with the objective of characterizing the rate distribution. Moreover, the authors considered a more general setup with the mmWave IAB network co-existing with the conventional ultra-high frequency (UHF) cellular network. The proposed analytical framework was verified by two realistic environment topologies. It was shown that the density of BSs can improve the rate coverage probability drastically. Compared with the increasing of BSs density, the improvement of bandwidth has a less positive effect on the rate of cell edge mobile users.

Because the bandwidth is shared between the access and backhaul links in the IAB-donor mode, the allocation of bandwidth plays an important role in network performance. In (Saha et al., 2018), the authors studied a setup that assumes a single macro-cell consisting of one anchored BS (i.e., IAB donor) surrounded by a smallcell BSs (i.e., IAB nodes) while the IAB nodes employed the OBHD mode. By using SG tools to capture the locations of SBSs and mobile users as well as the load of BSs, Saha et al. presented an analytical framework to characterize the rate coverage probability accurately. For instance, the authors first assumed the bandwidth of IAB donor is split into two parts: access bandwidth and backhaul link bandwidth. Further, Saha et al. investigated the impact of three different backhaul link bandwidth allocation strategies: (1) equal partition: all IAB nodes share the bandwidth equally; (2) instantaneous load-based partition: the backhaul link bandwidth allocated to an IAB node

is proportional to its instantaneous load; and (3) average load-based partition: the backhaul link bandwidth allocated to an IAB node is proportional to its average load. The simulation results showed that the coverage probability w.r.t the bandwidth splitting ratio at the IAB donor behaves like a concave function (i.e., there exists only one optimal splitting ratio in all considered strategies). Moreover, in terms of both coverage probability and the median rate, the performance of the three strategies can be sorted in a descending order as: instantaneous load-based > average load-based > equal.

In the follow-up work, Saha et al. considered a more general model setting which consists of multi macro-cells (Saha and Dhillon, 2019), the locations of the fiber-wired macro-cell BSs (MBSs) were modeled by a Poission point process. The authors proposed two bandwidth allocation strategies: (1) Integrated Resource Allocation (IRA): the bandwidth allocated equally for users; (2) Orthogonal Resource Allocation (ORA): the MBS reserved a fixed fraction of bandwidth to allocate to its directly served users, and allocate the rest of the bandwidth for the backhaul link to SBSs proportional to the load at each small-cell. In terms of rate coverage probability, the simulation results showed that the IRA outperforms ORA, and the improvement increases with the increasing of the density of SBSs. The reason behind these performance trends is that the fixed fraction reserved bandwidth backhaul link cannot deal with the increasing backhaul load results from increasing density of IAB nodes.

A semi-closed-form expression for the ergodic throughput of the two-tier IAB network was presented in (Zhang et al., 2018). Based on the proposed analytical model, the authors formulated and solved an optimization problem in order to maximize the number of offloaded mobile users, while satisfying the requirement for signal-to-interference-plus-noise ratio (SINR). Numerical results showed that the proposed method can achieve two times the improvement for the average user as well as the SBS throughput. The joint uplink (UL) and DL coverage probability under different resource allocation schemes in an mmWave-enabled IAB network was studied in (Kulkarni et al., 2017). In particular, the authors investigated the impact of static and dynamic time-division duplexing (TDD) scheduling policies at the access link, as well as the synchronized or unsynchronized time alignment at the backhaul link. Simulation results revealed that the combination of dynamic TDD and unsynchronized time alignment can achieve the best performance in terms of average DL and UL transmitting rate.

3.2. In-band FD (IBFD) Mode

In-band FD IAB node is the network framework in which IAB nodes can use the same time and frequency resource block to conduct reception and transmission. Therefore, there is no need to consider the bandwidth allocation in the IAB node operation. However, this mode will introduce the undesired interfering transmitted signal at IAB node's MT from a transmission from another IAB node's DU to the users, which is known as self-interference (SI). Since the distance of the interference source (DU) from the MT is significantly larger than that between the desired signal's source and the MT, SI is powerful enough to

TABLE 1 | Taxonomy of literature in section 3.

Objective	Network	References
Coverage probability	Multi macro-cells, TDD, mmWave	Kulkarni et al. (2017)
	hybrid UHF & mmWave, OBHD	Singh et al. (2015)
	Multi macro-cells, IBFD	Sharma et al. (2017)
	Single macro-cell, OBHD, mmWave	Saha et al. (2018)
	Multi macro-cells, OBHD, mmWave	Saha and Dhillon (2019)
	massive MIMO, OBFD	Tabassum et al. (2015)
Ergodic capacity	Multi macro-cells, IBFD	Zhang et al. (2018)

cause critical performance loss. Although there are numerous state-of-art self-interference cancellation technologies, residual self-interference (RSI) always exists (Duarte and Sabharwal, 2010; Bharadia et al., 2013; Phungamngern et al., 2013; Kim et al., 2015).

An analytical expression for coverage probability in massive multiple-input multiple-output (MIMO) wireless self-backhaul networks was derived in (Tabassum et al., 2015) by using SG tools. The considered two-tier network consists of a mixture of operating small-cells, each small-cell is assumed to adopt in-band or out-of-band backhaul mode with a certain probability. Both the existence of self-interference and cross-tier interference were considered for the signal-to-interference ratio (SIR) at mobile users. Simulation results revealed that implementing the considered mixture deployment consideration outperforms adopting only either in-band or out-of-band backhauling SBS option.

In (Sharma et al., 2017), the authors developed a framework to analyze the coverage probability and average DL transmission rate for a two-tier IAB network, where the MBS (i.e., IAB donor) is OBFD-enabled, and SBSs are IBFD-enabled. The trade-off between increasing interference and spectrum efficiency was investigated by the end-to-end analysis of the backhaul link and access link jointly. Numerical results showed that the DL rate in the considered system setting could achieve nearly two times gain compared to a traditional TDD or frequency-division duplexing (FDD) self-backhauling network. Meanwhile, due to the higher interference in IBFD mode, the coverage probability in the considered network is approaching half of its value in conventional TDD or FDD operation.

3.3. Section Summary

The comparison of individual studies on SG-based IAB network performance analysis is shown in **Table 1**. The main objectives of these studies are developing analysis frameworks to characterize the coverage probability and the ergodic capacity in large-scale IAB networks accurately. Due to the existence of orthogonal bandwidth resource partitioning, the system performance of the

OBHD IAB network is tied to the bandwidth partitioning ratio. This scheme can avoid the inter-interference between the access link and the backhaul link, with the sacrifice of efficient spectrum reuse. In order to enable efficient spectrum reuse, IBFD networks allow access and backhaul links to be transmitted in the same frequency band. However, the gains of IBFD transmission are degraded by the RSI, which is generated by the transmitter to its own receiver.

4. RESOURCE ALLOCATION IN IAB NETWORKS

4.1. Interference Mitigation

With the increasing mobile traffic and the existence of wireless backhaul hop, the number of transmission links in the IAB network is much larger than the past wireless networks that would introduce severe inter or intra interference at access and backhaul link. Thus, the performance of interference management can be an important issue in IAB network design. In (Li B. et al., 2015), the authors studied the average sum rate performance for three different duplex schemes in a massive MIMO-enabled IAB network. For instance, a TDD based duplex, an IBFD mode, and an IBFD mode with interference rejection (IBFD-IR) were considered. Based on zero-forcing (ZF) schemes, the authors formulated the beamforming matrix for UL and DL transmissions in all the considered schemes. The simulation results showed that IBFD and IBFD-IR schemes outperform TDD schemes when the distance between IAB donor and IAB nodes exceeds certain levels. The performance for IBFD-IR is better than IBFD but the performance gap decreases as the distance between IAB donor and IAB nodes increases.

Different from the case in (Li B. et al., 2015), the authors in (Ullah et al., 2016) investigated the incorporation of beamforming into interference mitigation based on the usage of limited-feedback information. In particular, for the DL transmission in an out-band IAB network, two different schemes based on antenna selection (AS) or quantized phase information (QCP) were proposed. The corresponding beamforming and interference mitigation weight vector for AS and QCP were determined by the received signal power and SNR, respectively. System-level simulation results showed that the combination of beamforming and interference mitigation can achieve nearly 9 and 6.4% compared with corresponding purely beamforming schemes. The performance of QCP-based beamforming and interference mitigation was found to be the best among the considered techniques.

In (Nakamura et al., 2019), a comprehensive mechanism aiming at managing the out-band backhaul intra-channel interference for a mesh-architecture mmWave IAB network was proposed. The proposed mechanism consists of node placement, sub-channel alignment, and transmitting power control. By solving a SIR maximization problem, the authors derived the optimal power allocation policy. It was shown that the proposed method can reduce interference up to a distance of 250 m away from the wired-backhaul node.

Flexible TDD-based resource scheduling can manage the frequency-time resources more efficiently. In (Jayasinghe et al., 2020), an iterative beamformer design for a TDD-based IAB network with one IAB donor and multiple IAB nodes was proposed. For a given time slot, IAB donor and IAB nodes operate in different UL/DL modes. By considering the traffic dynamics at each node and assuming each user and access point (AP) have a specific UL/DL queue, Jayasinghe et al. formulated and solved an optimization problem with the objective to minimize the weighted l_p -norm queue minimization of the UL and DL users during the two time slots. By comparing the proposed method with the half-duplex (HD) IAB system, the results showed that the performance of the proposed scheme is better for all considered traffic arrival rates.

4.2. Energy Consumption Minimization

In (Prasad et al., 2017), the authors proposed a coordinated mechanism to minimize network power consumption in an IAB network. By utilizing the information of QoS in the whole network, the controller cascaded with MBS can determine and inform which BSs or mobile users should enter into sleep mode along with a possible sleep time by discontinuous reception configuration (DRX). By simulation based on realistic network parameters, the presented mechanism is able to achieve up to 50% power saving in comparison with LTE. The problem to find optimal time allocation and power control for the mmWave IAB network was addressed in (Meng et al., 2018). The authors considered a multi-hop transmission system model, with one MBS and mesh connected SBSs. Each hop equipped with a status indicator to guarantee the hop transmitting priority. By formulating an optimization problem with the objective to minimize the overall energy consumption under throughput constraints, Meng et al. first established space/time-division multiple access groups, and then proposed a heuristic algorithm to derive the time allocation and power control policies. The proposed scheme was shown to be achieving a considerable performance boost compared with the Space-time division multiple access (STDMA) scheme (Zhu et al., 2016) and the maximum QoS-aware independent set (MQIS) scheme (Qiao et al., 2012).

The energy consumption minimization problems in a full-duplex (FD) IAB network was studied in (Korpi et al., 2018) and (Lei et al., 2018). Korpi et al. proposed a resource allocation scheme to minimize the energy consumption of a two-tier massive MIMO-enabled IAB network under the QoS constraint in (Korpi et al., 2018). In addition to the FD IAB scheme, a closed-form expression for the optimal transmitting power for HD and hybrid FD schemes was derived. In order to compare the performance of three considered schemes, the authors further derived feasibility boundaries for the DL and UL rate requirements in closed-form. It was shown that both FD and hybrid relay schemes are not able to guarantee the QoS constraints even as the transmitting power approaches infinity. Numerical results reveal that the FD schemes can achieve the lowest energy consumption among the three considered schemes. With the consideration of using non-orthogonal multiple access (NOMA) to enhance the spectrum efficiency, Lei et al. presented

an effective algorithm to minimize the energy consumption for a two-tier NOMA-enabled FD IAB network based on fixed-point iteration in (Lei et al., 2018). Numerical results showed that the performance gap between the proposed method and the orthogonal multiple access (OMA) based networks increases as the transmission rate requirements increases.

4.3. System Throughput Maximization

The rate of the mobile user associated with the IAB node is determined by the minimum rate between the backhaul link at this IAB node and the access link, which is obviously sensitive to the bandwidth partitioning strategies. The spectrum allocation can significantly influence the user's data rate, as analyzed in (Saha and Dhillon, 2019). Lei et al. derived the optimal bandwidth allocation policy for a two-tier IAB network, by solving a mixed-integer nonlinear programming problem with the objective to maximize the sum log-rate, with the usage of deep reinforcement learning (DRL) to derive the optimal solution in (Lei et al., 2020). Benefiting from the DRL, it is tractable to obtain the optimal allocation policy for the large-scale time-varying IAB network. Compared with the full-spectrum reuse strategy, simulation results showed that the proposed method can achieve considerable performance gain especially when the density of IAB networks is large. With the consideration of UL-DL and access-backhaul link transmission rate requirements, the joint UL and DL resource allocation mechanism for a TDD IAB-network was studied in (Liu Q. et al., 2018). In this mechanism, the optimization problem aims at maximizing the overall throughput and was decomposed into two subproblems on time slot orchestration and sub-band scheduling. Numerical results showed that total system throughput improves significantly compared with the conventional Round Robin (RR) and Proportional Fair (PF) mechanisms.

As for in-band IAB network, the trade-off between self-interference and spectrum efficiency was investigated in (Korpi et al., 2016; Lagunas et al., 2017a; Siddique et al., 2017; Zhang S. et al., 2020). The authors in (Lagunas et al., 2017a) obtained the optimal power allocation policy by solving the DL sum rate maximization problem in an IBFD IAB network. Based on the standard optimization method, a closed-form expression for optimal transmitting power was derived in (Korpi et al., 2016) by solving the optimization problem with the objective to maximize the network sum rate of DL and UL. The authors considered both the IAB donor and IAB node are working in the IBFD mode, where the mobile users adopt the HD mode. Simulation results showed that the proposed solution can achieve the best performance when UL and DL rate requirements are close. In (Zhang S. et al., 2020), the optimal spectrum and power allocation policies were derived by sequential convex programming (SCP) method. The authors considered a mmWave in-band IAB network with one IAB donor surrounded by multiple IAB nodes, where partial users could reuse the backhaul bandwidth resources. The formulated problem was under the heterogeneous user's DL transmission rate requirements. Compared with the simple power allocation optimization, the proposed algorithm can achieve a nearly 25 % gain in terms of system throughput. Similar to (Korpi et al., 2018),

the authors in (Siddique et al., 2017) investigated the sum-rate maximization problem in IBFD, OBFD, and hybrid IBFD/OBFD backhauling networks. By using the convex optimization method and bisection search algorithm, the authors derived the solutions for optimal spectrum allocation policies for three considered scenarios. With two heuristic methods based on received signal power, three distributed algorithms and coverage probability were derived for corresponding backhauling schemes. It was shown that IBFD outperforms OBFD when self-interference cancellation exceeds a certain level. Moreover, IBFD tends to allocate more spectrum resources for the SBSs close to MBS while OBFD is just the opposite.

Using tools from game theory, the authors in (Liu Y. et al., 2018) obtained the joint optimal power control and transmission slot allocation policies for a two-tier mmWave IAB network. For the formulated non-cooperative game with the objective of sum rate maximization, the authors first proved the existence and feasibility of the Nash equilibrium then designed a centralized resource allocation algorithm as well as a decentralized algorithm based on the functionality splitting architecture at the IAB nodes to solve it. Simulation results showed that the proposed algorithms can achieve at least 17.94% improvement compared with pure optimization for power control. The joint optimal backhaul and access link resource allocation policies for a two-tier tIAB network were studied in (Lashgari et al., 2017). In order to maximize the overall DL data rate, the problem was formulated into a Stackelberg game form. The wired-backhaul MBS plays the role of the leader, while the SBSs act as the followers. For instance, the optimal sub-carriers allocating policies for MBS and SBSs were derived from the leader's and followers' optimization problems, respectively. An optimal power control strategy was obtained from the follower's problem. Numerical results proved that the presented algorithm can improve the performance up to 14.2 and 24.9 %. By integrating game theory tool and reinforcement learning (RL), the authors in (Blasco et al., 2013) presented a game-theoretic leaning mechanism to maximize the UL sum rate in an in-band IAB network. The proposed mechanism is supportable for self-organizing, which means that the MBS enables throughput balancing in a decentralized way. In comparison with non-IAB mechanism, the proposed mechanism can achieve up to 40% performance improvement.

With the objective to maximize the weighted sum-rate in a mmWave IAB heterogeneous network (HetNet), the joint optimal strategies for transmitting power allocation, time splitting ratio, mobile users association, and beamforming design were proposed in (Kwon and Park, 2019). Time splitting manner is considered between backhaul and access links. The access link design includes the mobile users association and beamforming design by using limited channel state information (CSI). By simulation, the performance of the proposed limited feedback hybrid beamforming scheme was shown to be able to approach the performance of the digital beamforming scheme with full CSI. The spatial multiplexing gain increases up to the number of radio frequency (RF) chains for the IAB node.

The DL sum rate maximization problem in an enhanced hybrid IAB network was studied in (Ni et al., 2019). For instance, with the aim to extend the coverage of IAB nodes, the authors

first considered that the access link is working in sub-6 Hz while the backhaul link is working in mmWave, and then proposed a hybrid precoder to improve the backhaul transmission rate. Numerical results revealed that the performance of the presented precoder is close to the conventional block diagonalization precoder, with a significant decline for the required number of the RF chains. In (Pu et al., 2019), the authors considered a network with multi-antenna IAB nodes, and the transmission link can be allocated with an orthogonal sub-channel when it suffers from severe interference. By introducing the penalty function and factors, Pu et al. first transformed the sum rate maximization problem into 0-1 integer programming without any inequality. Further, a resource allocation algorithm based on Markov approximation with polynomial time complexity was proposed. The performance evaluation showed the sum rate for the proposed scheme increases faster than OBFD scheme as the number of antennas increases.

In (Yang et al., 2020), the authors addressed the sum rate maximization problem in a NOMA-enabled out-band IAB network, where a typical mobile user is only assumed to be served by two SBSs. Two decoding strategies based on different SIC decoding orders were considered at DL access and backhaul links. By using convex-concave procedure (CCP) method, the authors derived the optimal power allocation policies for UL and DL transmissions. It was shown that decoding better channel quality signals first outperforms the other decoding strategy. Compared with OMA, the performance improvement of considered NOMA-enabled network increases as the number of mobile users increases. With the consideration that mobile users can be served by a cluster of SBSs cooperatively, the authors in (Chen et al., 2018) addressed the joint beamforming and SBSs clustering problem for IBFD IAB network. In order to maximize the overall DL transmission rate, a manifold optimization problem was formulated under the transmitting power constraints. By using Riemannian optimization technique, a heuristic algorithm was presented to derive the optimal policies for the SBSs clustering and beamforming vectors. Extensive simulations showed that optimal cluster size is related to the transmitting power constraint for the IAB donor. The extension of (Chen et al., 2018) from full CSI to partial CSI is presented in (Chen et al., 2019). To this end, a stochastic successive lower-bound maximization algorithm and a deterministic algorithm with lower time complexity were proposed to solve the modified sum-rate maximization problem. Moreover, the performance gap between (Chen et al., 2019) and (Chen et al., 2018) was shown to be decreasing as the cluster number increases.

4.4. Utility Optimization

The maximization of network utility with interference management in the DL transmission of a mmWave IAB HetNet was considered in (Vu et al., 2017). The authors developed a Lyapunov optimization framework to decouple the primal optimization problem and used convex optimization and successive convex approximation method to derive the optimal solution for user association, beamforming design, and power allocation. Simulation results revealed that the proposed scheme can achieve 5.6 times gain in cell-edge users throughput

compared with un-optimized user allocation scheme with a density of SBSs equal to $350/\text{Km}^2$. A more general setting for multi-hop multipath scheduling is contemplated in (Vu et al., 2019). Vu et al. formulated a network utility function under low latency and network stability in order to achieve ultra-low latency and reliable communication (ULLRC). A RL-based algorithm and a Lyapunov optimization algorithm were proposed to derive the optimal solution for path selection and rate allocation, respectively. Compared to (Vu et al., 2017), it was shown in the simulation that the proposed scheme can provide reliable communication with a guaranteed probability close to 100% and a latency reduction at least 50%.

Wireless network virtualization empowers the resources at the network infrastructure provider (InP) to be sliced into several virtual parts, which can be shared by multiple service providers (SPs) (Liang and Yu, 2014). In (Chen et al., 2016b), the authors investigated the application of wireless network virtualization technique into a FD IAB network. They assumed both MBS and SBS from multiple InPs can be virtualized and shared by mobile users from different mobile virtual network operators (MVNOs). To solve the utility maximization problem with the aim to maximize all the profit of MVNOs and cost of resource consumption, a two-stage iterative algorithm based on convex programming was proposed. Numerical results showed that the proposed algorithm can achieve convergence within 15 iterations and significant average throughput improvement for the small-cells. The authors in (Tang et al., 2018) addressed the time-average utility maximization for an IAB network with wireless network virtualization. In particular, they considered the requirements for network queue stability, average throughput of different SPs, and backhaul link capacity. A Lyapunov optimization-based algorithm was proposed to find the optimal strategy for bandwidth portioning ratio, user association, and percentage of resources allocated by the associated BS. In comparison with the traditional networks without virtualization techniques, the proposed scheme can result in at least 60% increment of average total utility.

4.5. Spectral and Energy Efficiency Maximization

In (Chen et al., 2016c), the authors considered integrating energy harvesting (EH) technique into an IBFD IAB network with the aim to improve energy efficiency (EE). The MBS is equipped with massive MIMO antennas array, and the SBS is equipped with a multi-antenna array and can harvest energy from renewable resources. The authors first proposed a precoder to mitigate the self-interference and cross-tier interference, and then used the CCP method to obtain the optimal power control and mobile users association policies by solving the energy efficiency maximization problem. Compared with the conventional OBFD network, it was found that the proposed method can dramatically improve EE for dense SBSs deployment.

The spectral efficiency maximization problem in the IAB network was studied in (Imran et al., 2014; Chen et al., 2016a). In particular, the joint optimization of backhaul and access links with the aim to maximize spectral efficiency (SE) in OBFD IAB

networks was studied in (Imran et al., 2014). By using a sequential quadratic programming (SQP) algorithm, the optimal antenna tilt angle deployment policies were derived. The proposed schemes can achieve up to 50% performance improvement compared with fixed-tilt deployment. With the consideration of IBFD mode, (Chen et al., 2016a) addressed the SE optimization problem under DL backhaul capacity requirements. After the transformation of the primal optimization problem, the optimal power allocation policy was derived using SCP-based algorithm. The IBFD IAB network was shown to be able to bring about 25% SE performance improvement.

4.6. Section Summary

A comparison of the studies addressing the resource allocation problems for the IAB networks is shown in **Table 2**. The related literature aims at finding optimal policies to improve the system performance, including of interference mitigation, energy consumption minimization, throughput maximization, utility optimization, and the maximization of spectral and energy efficiency. A common drawback of all mentioned methods in this section is that the deployment of the IAB nodes was disregarded. With the realization of network densification, the QoS of UEs is highly dependent on the length of the transmission links, especially when the BSs are adopting high frequency signal carriers. Besides, the proper design of scheduling policies are important to reduce the UEs dissatisfaction in IAB networks. This issue is addressed in the following section, which is targeting scheduling in IAB networks.

5. NETWORK DEPLOYMENT AND SCHEDULING IN IAB NETWORKS

Since the wireless links in the network are implemented by sharing the communication resources, the flexible deployment of the IAB network brings an emerging demand for efficient scheduling to realize high throughput and low latency while guaranteeing users fairness. The wireless communication resources scheduling consists of the user scheduling and the link scheduling (Pathak and Dutta, 2011; Ge et al., 2018). For instance, user scheduling is aiming at exploiting the multi-user diversity by the proper selection of users for transmissions in different time slots, and the goal of the link scheduling is to achieve conflict-free feasible transmission schedule based on the estimation for the interference conflicts between the different links with different transmission demands (Hajek and Sasaki, 1988). Due to the complexity of network topology in the IAB networks, in addition to classical scheduling techniques [e.g., Proportional fair (PF) and backpressure algorithms], researchers have proposed some novel centralized or distributed schedulers based on RL, game theory, and matching theory (Yuan et al., 2018; Chaudhry et al., 2020; Zhang B. et al., 2020). This section surveys current research related to the design of network deployment scheduling policies in IAB networks.

5.1. Deployment Design

Due to the higher path loss and penetration loss, the coverage area of the network operated in high frequents is limited by

TABLE 2 | Taxonomy of literature in section 4.

Objective	Methodology	Network	Optimization parameters	References
Interference mitigation	Random matrix	massive MIMO, IBFD	Beamforming matrix	Li B. et al. (2015)
	Heuristic method	MIMO, IBFD		Ullah et al. (2016)
	Convex optimization	MIMO, TDD		Jayasinghe et al. (2020)
Energy consumption minimization	Random matrix, Heuristic approach	mmWave, mesh backhauling	Channel alignment, power control, node placement	Nakamura et al. (2019)
	Heuristic method	DRX	Time allocation	Prasad et al. (2017)
	Heuristic method	mmWave, multi-hop backhaul	Time allocation, power control	Meng et al. (2018)
Throughput maximization	Convex optimization	massive MIMO IBFD	Power control	Korpi et al. (2018)
	Alternative optimization	NOMA, IBFD		Lei et al. (2018)
	DRL	OFDMA	Bandwidth allocation	Lei et al. (2020)
	Heuristic method	TDD	Time allocation, bandwidth allocation	Liu Q. et al. (2018)
	Water-filling algorithm	IBFD	Power allocation	Lagunas et al. (2017a)
	Random matrix	MIMO, IBFD		Korpi et al. (2016)
	SCP	mmWave, IBFD	Power allocation, bandwidth allocation	Zhang S. et al. (2020)
	Convex optimization, bisection search	hybrid IBFD and OBFD	Bandwidth allocation	Siddique et al. (2017)
	Game theory	mmWave	Time allocation, power control	Liu Y. et al. (2018)
	Game theory	OBFD	Sub-carrier allocation	Lashgari et al. (2017)
	Game theory, DRL	IBFD	Power control	Blasco et al. (2013)
	Random matrix, Alternative optimization	mmWave, hybrid beamforming	Power control, time allocation, user association, beamforming matrix	Kwon and Park (2019)
	Random Matrix	Hybrid mmWave, Sub-6 GHz	Beamforming matrix	Ni et al. (2019)
	Markov approximation	OBFD	Sub-carrier allocation	Pu et al. (2019)
	Utility optimization	CCP	NOMA	Power control
Riemannian optimization		IBFD, full CSI	Beamforming matrix, SBSs clustering	Chen et al. (2018)
SCP		IBFD, partial CSI		Chen et al. (2019)
Lyapunov optimization		mmWave	User association, beamforming matrix, power control	Vu et al. (2017)
RL, Lyapunov optimization		mmWave, multi-hop backhaul	Rate allocation, user association	Vu et al. (2019)
	Alternative optimization	Network	Bandwidth allocation, user association	Chen et al. (2016b)
	Lyapunov optimization	virtualization		Tang et al. (2018)

(Continued)

TABLE 2 | Continued

Objective	Methodology	Network	Optimization parameters	References
EE maximization	CCP	massive MIMO, EH, IBFD	Beamforming mateix, power control, user association	Chen et al. (2016c)
SE maximization	SQP	OBFD, Self-organizing network	Antenna tilt angle	Imran et al. (2014)
	SCP	IBFD	Power control	Chen et al. (2016a)

both the number and locations of BSs. In (Bonfante et al., 2018), the authors investigated the *ad-hoc* deployments in a massive MIMO-enabled IAB network, where the SBSs were positioned in proximity to mobile users. In (Wainio and Seppanen, 2016), a self-optimizing deployment framework for an IAB mesh network was developed. Based on the neighbor discovery, the proposed framework enables autonomous deployment for the newly added nodes. Taking into account the height of nodes, the authors investigated the joint resource allocation and node deployment problem for a MIMO-orthogonal frequency-division multiple access (OFDMA) based IAB network in (Lai et al., 2020). Since only the IAB donor is connected to the core network *via* wired fiber in IAB network, the location of IAB donor in a set of BSs can determine the quality in multi-hop wireless backhauling. A genetic algorithm (GA) in combination with the K-means clustering method to select the location of IAB donor to maximize the backhaul capacity was proposed in (Raithatha et al., 2020). Through extensive Monte Carlo simulations, the authors evaluated the performance of this algorithm in comparison with the conventional genetic algorithms and K-means clustering in terms of the average number of hops and backhaul network capacity at different node densities. Simulation results showed that the proposed algorithm can achieve at least 20.2% and 19.8% a performance improvement in the average number of hops and backhaul capacity, respectively.

The trade-off between deployment cost and network performance brings more challenges in the deployment design in the IAB network. In (Islam et al., 2017), the authors formulated a mixed-integer linear program problem with the objective to minimize the cost of required fiber-wired BSs deployment and used the branch-and-bound algorithm to obtain the optimal solutions of deployment, routing, and resource allocation on each flow in a single-tier IAB network. Simulation results showed that IAB is able to reduce the amount of fiber-wired BSs deployment significantly. Another interesting conclusion is that there were only 6.5% links larger than the specific noise tolerance when the optimization problem formulation did not consist of interference from inter-links. The BSs deployment problem for a two-tier IBFD IAB network was studied in (Rezaabad et al., 2018). With the aim to minimize deploying cost and maximize coverage, the optimal number of IAB donors and IAB nodes was derived from a non-dominated sorting genetic algorithm. Numerical results confirmed the trade-off between BSs deployment costs and coverage. For realistic network topology, the authors showed that the optimal deployment solution can be derived from

the Pareto front of the multi-objective optimization problem according to operator policy.

5.2. Routing

With the introduction of wireless backhaul links and the support of multi-hop backhaul, the design of routing policies in the IAB network should be able to scale together with the increasing complexity. In the study by Zhang X. et al. (2019), the end-to-end ergodic capacity for an IAB network was shown to be decreasing as the number of hops increases. In order to maximize the overall sum rate as well as minimize the average latency, the joint route selection and radio resource allocation optimization for an indoor IAB network were studied in (Hui and Axnas, 2013). Based on the virtual-network method, the design of routing and radio resource allocation among different links can be optimized independently. As expected, by ray-tracing simulations, the number of IAB donors has a positive impact on the performance of the proposed centralized scheme. The authors in (Favraud et al., 2017) considered an outdoor in-band mesh-architecture for the IAB network. Under the constraints of the QoS, the centralized and semi-centralized joint routing and power control mechanism were presented. This mechanism is realized by a logical controller which manages the network across the MAC layer. It was shown that the proposed mechanism does not need intense modifications on current standards while providing robust performance for real-time flows.

The optimal flow link resource allocation and routing policies to maximize the geometric mean of users in a single-tier multi-hop mmWave IAB network is proposed in (Islam et al., 2018). The authors investigated different routing patterns and found that the top 20 percentile user rates in IAB with RSRP-based ST outperform the IAB with mesh. The suboptimal allocation of the subcarriers and the transmitting power are derived by the dual-decomposition method, and a systematic approach to determine the optimal node locations was developed. Simulation results revealed that the performance gap between the optimal and the proposed suboptimal method is negligible. In (Lukowa et al., 2018), the authors addressed the dynamic scheduling problem for a mmWave DAG network, where BSs are equipped with multiple antenna panels. By considering flexible access/backhaul TDD and dynamic route selection, a heuristic based centralized scheduling scheme was presented. Both median and 5th percentile of UL and DL rate for the proposed scheme were shown to be improved significantly by system-level simulation.

Different from the centralized solution in (Hui and Axnas, 2013; Islam et al., 2018), four distributed greedy path selection strategies: (1) Highest-quality-first (HQF), (2) Wired-first (WF) policy, (3) Position-aware (PA) policy, and (4) Maximum-local-rate (MLR) were studied in (Polese et al., 2018). The HQF and MLR policies are implemented by selecting the node with the best SNR and achievable rate, respectively. As for the WF policy, the IAB node prefers to connect with the reachable IAB donor if the SNR exceeds a given threshold. Otherwise, the IAB node will connect with the node with the highest SNR. The PA policy is based on the position information, the IAB node will connect with the highest SNR node selected from the candidate nodes which are closer to the target IAB donor than current IAB node. Moreover, in order to maintain a small number of hops for the proposed HQF, WF, and MLR policies, the authors introduced two wired bias functions, which are polynomial and exponential in the number of hops, respectively. The wired bias function is applied to the SNR of the wired IAB donor and takes the value which is larger than the fixed tolerable SNR level when the number of traveled hops reaches the threshold. Simulations revealed that aggressive bias function is able to decrease the number of hops needed to connect to an IAB donor.

As shown in (Zhai et al., 2020), mesh-architecture IAB network can achieve 6.70~40.56% overall throughput improvement compared with DAG-architecture IAB network. The authors in (Gomez-Cuba and Zorzi, 2020a) addressed the joint link scheduling and power allocation problem in a mesh-architecture IAB network with multi-user MIMO (MU-MIMO) and elastic traffic arrival process. To maximize the overall throughput, a modified backpressure algorithm and an adaptive congestion control algorithm were proposed to obtain the optimal policies for link connectivity decision, power allocation, and traffic allocation. The proposed method was proved to achieve a stable performance by stochastic analysis. However, the study in (Gomez-Cuba and Zorzi, 2020b) is based on the perfect link directivity, which ignores the inherent interference. In this context, the authors considered using a simulated annealing heuristic algorithm to solve the overall throughput maximization problem and investigated the impact of minimal feedback and sophisticated beamforming. Simulation results showed that a more sophisticated beamformer enables the proposed algorithm to achieve sum rate performance closer to an interference-free scenario.

In order to obtain a tractable optimal solution for routing in the harsh propagation and dynamic environment of the mmWave IAB networks, RL with the promising capacity to deal with a massive number of parameters was applied in (Gupta et al., 2019; Zhang B. et al., 2020). By utilizing full or partial knowledge of the network state, the authors in (Gupta et al., 2019) proposed two corresponding routing policies based on the integration of deep deterministic policy gradient (DDPG) algorithm into RL. The optimal routing policies are aiming at minimizing the transmission delay by allocating the proper time slot for each link. Numerical results show that the proposed method can achieve at least 2.6 times gain compared with a max-min scheduler (Kulkarni et al., 2017) and backpressure scheduler (Tassioulas and Ephremides, 1992). In (Zhang B. et al.,

2020), the authors introduced a RL-based approach to maximize throughput in a mmWave IAB network. The routing policy is determined by the column generation (CG) method and the flow control policy was derived by the RL-based algorithm. Further, two schedulers for off-line and on-line model framework were proposed, respectively. Compared with the purely CG-based method and random pattern selection method, the proposed method can achieve at least 10% performance improvement.

It is clear that the wireless backhaul capacity is related to the number of simultaneous transmitting links. The authors in (Chaudhry et al., 2020) proposed a routing mechanism to optimize the average number of simultaneous transmissions and hops. The problem of maximizing the average number of simultaneously transmitting links is similar to the minimum coloring problem, a heuristic algorithm was proposed to solve this problem. The average number of transmitting hops is determined by Dijkstra's shortest path algorithm. Numerical results showed that the backhaul network capacity increases as the node density increases or the interference range decreases. In (Ortiz et al., 2019), the authors proposed a semi-distributed learning-based algorithm to minimize the end-to-end latency while enhancing the robustness against network dynamics in a two-tier IAB network. The considered network dynamics include load imbalance, channel variations, and link failures. By formulating a Markov decision process to capture the routing and resource allocation decisions, a learning algorithm without the requirement of prior information was developed. Simulation results showed that the proposed algorithm achieves at least 1.8 times throughput gain compared with the RL benchmark.

5.3. Fairness

From the point of view of the user, the service provider needs to focus on fairness to meet their satisfaction requirements. In general, the fairness in wireless networks is attributed to the resource sharing. An unfair resource allocation among different users will result in resource starvation, wastage, or redundant allocation. For different researchers, it is rather difficult to agree on a single definition of fairness since it is subjective (Shi et al., 2014). Based on the measurability, the fairness measures can be classified as quantitative or qualitative. The Jain's index (Jain et al., 1984) and the Shannon entropy (Shannon, 2001) are the two most common quantitative measures of fairness, and the qualitative measures of fairness can be characterized by max-min (Radunovic and Le Boudec, 2007) and proportional fairness (Kelly, 1997). By optimizing a specific type of fairness measure, the fairness performance in IAB networks was shown to improve in (Siddique et al., 2015; Goyal et al., 2017; Yuan et al., 2018; Zhang Y. et al., 2020). In this subsection, we survey the scheduling studies in the IAB network intending to guarantee users fairness.

In the study by Yuan et al. (2018), the authors addressed the maximum throughput fair scheduling (MTFS) problem in a TDMA mmWave HetNet with one multiple-RF-chains-equipped IAB donor and multiple single-RF-chain-equipped IAB nodes. The topology of the considered system is represented by a directed graph, corresponding to an adjacency matrix. A two-step approach was presented to solve the MTFS problem:

first, maximize the max-min throughput and then find the optimal scheduling solution to maximize network throughput for the given max-min throughput. Based on the matching theory and ellipsoid algorithm, the authors first proposed an optimal MTF algorithm with polynomial time complexity. Next, they developed an edge-color approximation algorithm with improved runtime efficiency. Simulation results showed that the proposed optimal algorithm could converge for a few minutes at over 200 IAB nodes. The edge-color approximation method can be 5 to 100 times faster with a performance decline of up to 20%.

The authors in (Siddique et al., 2015) investigated the scheduling problem in a hybrid IAB network. The considered network enables an IAB node to switch its operating mode between HD and IBFD. Analytical expressions for DL and UL transmission rates for users were first derived. Based on the overall fairness of users, the IAB node can select the mode which contributes the largest value. For dense IAB node deployment scenario, simulation results showed that IAB nodes prefer to select IBFD mode to improve users' fairness. PF scheduling was proved to be not suitable for multi-hop network in (Andrews et al., 2017). The impact of applying a modified PF scheduling in a multi-hop IAB network was studied in (Zhang Y. et al., 2020). By adding a weight related to the numbers of users served by the IAB node, the authors proposed a weighted proportional fair (WPF) algorithm. Moreover, an IAB-aware flow control algorithm aiming at improving the system throughput and mitigating congestion were given. Compared with the original PF integrated with the traditional end-to-end flow control, the proposed scheme can result in a 30 and 2% increment of fairness index and system throughput, respectively. Under a strict fairness requirement, the joint flow control, user association, and power control for an in-band IAB network was studied in (Goyal et al., 2017). The optimal power control and flow control policies were derived by using a backpressure algorithm and geometric programming, respectively. In comparison with the out-band IAB network, the throughput at the in-band IAB node was shown to be doubled.

5.4. Incentive Mechanism Design

As a promising approach to address the multi-objective optimization problems in wireless networks, the application of economic and pricing models in the wireless network has attracted much attention from the research community (Luong et al., 2019). The trade-off between the revenue of IAB nodes and mobile users satisfaction in an IBFD network was investigated in (Rahmati et al., 2015). The authors proposed a price-based scheme by using the Stackelberg game theory. For instance, the IAB nodes act as the leaders, while their mobile users act as the followers. The mobile user can be regarded as a buyer with the aim to maximize the difference between its gained transmission rate and the payment, while the IAB node aims at maximizing its revenue under a specific power allowance. An iterative algorithm was proposed to obtain the price for the resource and the power allocation policy which reaches the state of proved unique Stackelberg equilibrium.

In a user-provided network (UPN), users can serve as providers, directly offering connectivity to other users (Sofia and

Mendes, 2008). This architecture can provide users with a good channel condition when the link to the BS suffers from poor quality in a device-to-device (D2D) mode. However, in practice, users would have no incentive to be such a provider unless they receive satisfying rewards from the operator to compensate for their transmitting cost. By considering a D2D mode UPN under mmWave IAB HetNet, joint incentive and resource allocation design was studied in (Liu et al., 2020). The authors formulated a Nash bargaining problem under the user utility, the sensitivity of battery energy, the incentive compensation, and the limitation of network resources constraints. A centralized algorithm and a distributed algorithm were proposed to derive optimal Nash bargaining solution and decoupled sub-problem, respectively. The performance of the proposal is evaluated in terms of pay off, download data, and the operator's revenue. It was shown that the joint optimization scheme can outperform the optimized resource or incentive only at least 16% in every performance metric.

5.5. Network Coding-Aware Scheduling

Network coding enables the router to broadcast a mixture of information packets. Due to its potential to provide energy-efficient and high throughput performance, network coding has found a wider acceptance in the academia and industry (Fragouli et al., 2006; Iqbal et al., 2011; Magli et al., 2013). For a HD hexagonal wireless backhaul network where the MBS transmits a linear combination of the messages to a set of SBSSs, the per user degrees of freedom was shown to be approaching 1/2 in (Bande and Veeravalli, 2020). In (Thomsen et al., 2015), the authors considered the integration of XOR network coding with the IAB network. It is assumed that the message sent by an IAB donor can be split into a common part and a private part. An IAB node can XOR its decoded signal and broadcast the result to the mobile user and the IAB donor for DL and UL transmissions, respectively. With the aim to minimize the energy consumption of the IAB donor, the authors proposed the optimal policies for message splitting ratio, private part transmitting power, and common part beamformer design. Meanwhile, the energy consumption minimization problem for the IAB nodes was formulated and solved by the convex optimization method.

The drawback of (Thomsen et al., 2015) is that only one-hop wireless backhaul is supportable and two mobile users are considered. The properties of multi-hop backhaul and multi-route topology for the IAB network bring new challenges. In (Mao et al., 2020), with the consideration of more complex topology in the IAB network, the authors proposed a linear network coding solution to enhance the performance robustness and reduce the latency. A rate-proportional mechanism and an adaptive coded-forwarding mechanism were proposed to balance the traffic load among routes and determine the ratio of coded messages, respectively. Compared with the Round-Robin mechanism, the rate-proportional mechanism can improve 25% spectral efficiency performance. In comparison with the ARQ retransmission, for a given input data rate, the adaptive coded-forwarding mechanism doubled the success rate.

TABLE 3 | Taxonomy of literature in section 5.

Objective	Methodology	Network	References
Deployment design	Heuristic method	massive MIMO, <i>ad-hoc</i>	Bonfante et al. (2018)
	Convex optimization	OFDMA, MIMO	Lai et al. (2020)
	Heuristic method	mesh multi-hop backhaul, mmWave	Wainio and Seppanen (2016)
	K-means clustering, Genetic algorithm		Raithatha et al. (2020)
	branch-and-bound algorithm	multi-hop backhaul, mmWave	Islam et al. (2017)
	Genetic algorithm	IBFD	Rezaabad et al. (2018)
Routing	Virtual-network method	mesh multi-hop backhaul, mmWave	Hui and Axnas (2013)
	Heuristic method	mesh multi-hop in-band backhaul, mmWave	Favraud et al. (2017)
	Convex optimization	multi-hop backhaul, mmWave	Islam et al. (2018)
	Heuristic method	dual-hop backhaul, TDD, mmWave	Lukowa et al. (2018)
	Distributed greedy algorithm	multi-hop backhaul, mmWave	Polese et al. (2018)
	Backpressure algorithm	multi-hop backhaul, mmWave MU-MIMO	Gomez-Cuba and Zorzi (2020a)
	Simulated annealing algorithm		Gomez-Cuba and Zorzi (2020b)
	DRL	multi-hop, mmWave	Gupta et al. (2019)
	RL, CG method		Zhang B. et al. (2020)
	Semi-distributed learning algorithm	Dynamic mmWave network	Ortiz et al. (2019)
Fairness	Heuristic algorithm	mmWave	Chaudhry et al. (2020)
	Matching theory	TDMA mmWave	Yuan et al. (2018)
	Heuristic method	hybrid IBFD & OBHD	Siddique et al. (2015)
	WPF algorithm	DAG multi-hop backhaul	Zhang Y. et al. (2020)

(Continued)

TABLE 3 | Continued

Objective	Methodology	Network	References
	Backpressure algorithm	IBFD	Goyal et al. (2017)
Incentive Mechanism	Game theory	Dual-hop backhaul	Rahmati et al. (2015)
	Game theory	UPN, multi-hop backhaul	Liu et al. (2020)
Network coding-aware scheduling	Convex optimization	XOR network coding	Thomsen et al. (2015)
	Coding design	Linear network coding, multi-hop backhaul	Mao et al. (2020)

5.6. Section Summary

This section mutually introduces and compares literature for addressing the problems of network deployment and scheduling in the IAB networks. **Table 3** provides a taxonomy for the literature according to the network model and the technique, and the majority of works focus on the multi-hop backhaul IAB networks. The common drawback of all proposed solutions is that the mobility of the UEs is disregarded. In networks with a higher density of BSs, the movement of UEs will incur a more frequent need of handover, which brings additional challenges in the design of deploying and scheduling policies.

6. CACHE-ENABLED IAB NETWORKS

Caching is able to improve the QoS experienced by users, reduce the overall network traffic, and prevent the network congestion (Yao et al., 2019). By caching popular contents from remote servers in network devices positioned closely to mobile users, the burden of wireless backhaul can be alleviated. **Figure 5** provides a simple example of a cache-enabled IAB network, in which each BS with finite cache size can store some contents to serve mobile users. In this section, we survey the research focused on cache-enabled IAB network.

6.1. Successful Probability and Throughput Analysis

The authors in (Wang et al., 2018) considered a two-tier edge caching system, with limited storage resource SBSs and MIMO-enabled MBS. The analytical framework for the successful content delivery probability (SCDP) was developed using tools from SG. Further, a one-dimensional search algorithm was proposed to obtain the minimum BSs density and maximum load at a small-cell under the SCDP requirement, respectively. Simulation results revealed that the hit probability should be less than a certain level to achieve a given SCDP. The reason behind this requirement is that the larger hit probability could introduce more interference from SBS-tier and degrade the performance of cached content delivery. Also, it was shown that the delay of

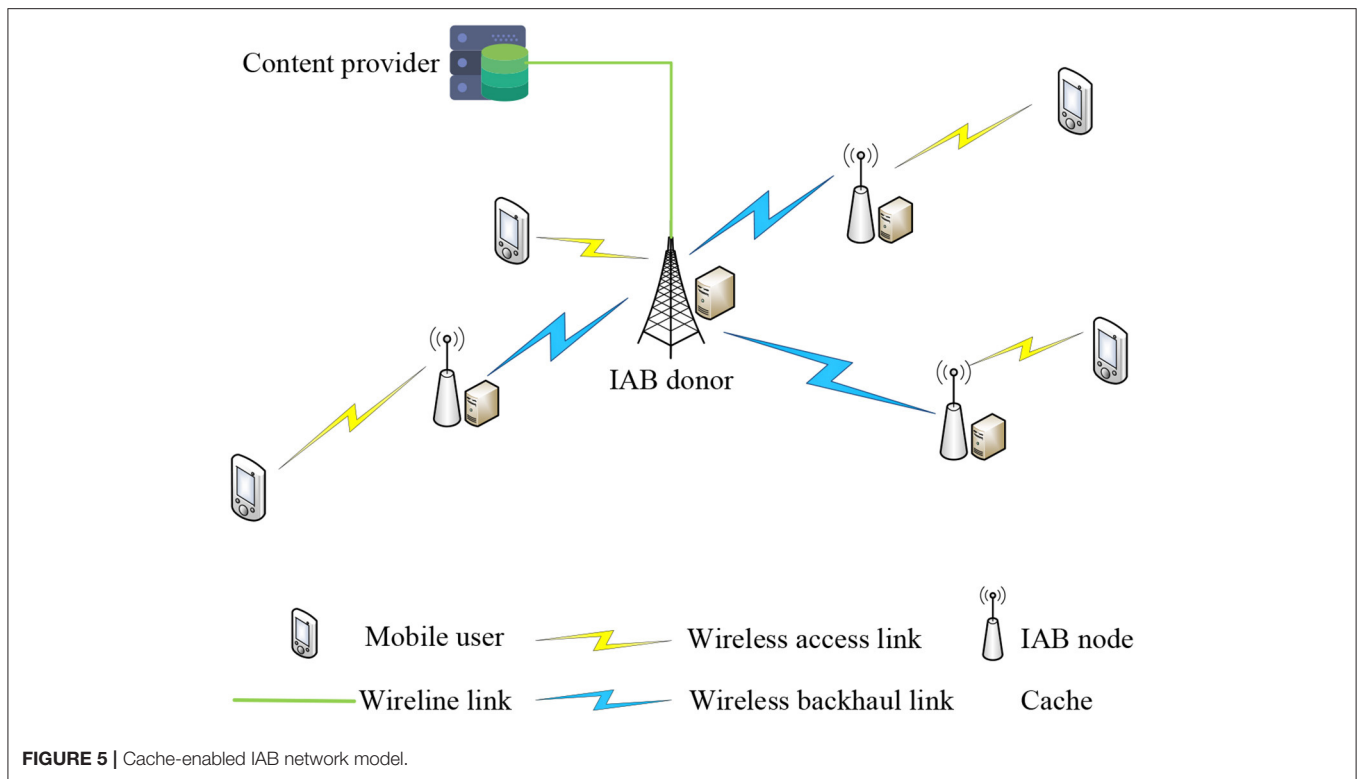

non-cached content requests can be reduced close to the cached content request with the aid of MIMO-enabled backhaul.

With the consideration of using IBFD wireless backhaul, the authors investigated the average success probability (ASP) for a cache-enabled mmWave IAB network in (Zhang T. et al., 2019). The IAB nodes serve multiple users in IBFD mode with hybrid beamforming. IAB nodes equipped with a storage memory to pre-cache popular contents in order to alleviate network traffic loads. The authors assumed a tuning parameter to control the amount of RSI and investigated two caching strategies: uniform (UC) and M most popular files (MC), then derived the average rate, latency, and upper-bound for the average success probability (ASP) of file delivery. In addition to investigating the latency and mean throughput, the authors derived a lower-bound for the ASP of content delivery. Simulation results showed that the MC significantly outperforms UC for ASP, and the performance gap of rate and latency between IBFD and OBHD decreases as the storage space at the IAB nodes increases.

In (Zhang C. et al., 2020), the authors derived the average potential throughput (APT) of a two-tier out-band mmWave IAB cache-enabled network. The IAB donors are connected to the core network *via* optical fiber links and contain all kinds of files. Similar to (Saha et al., 2018) and (Saha and Dhillon, 2019), the total spectrum resource at IAB donor for the DL is partitioned into access and backhaul with a fixed ratio for the whole system. By using a SG tool, the authors developed an analytical framework to capture the SINR statistics and APT of users associated with each tier. Simulation results showed that the considered cache-enabled setting can achieve 80% APT improvement compared with the traditional setting.

6.2. Caching Strategy Design

The cached content placement decision model is captured by fixed hit probability in (Wang et al., 2018; Zhang T. et al., 2019; Zhang C. et al., 2020). As suggested in (Wang et al., 2018) and (Zhang T. et al., 2019), the hit probability plays an important role in the network performance. In order to find the optimal content caching decision at the IAB nodes and the mobile users association policy, the authors in (Haw et al., 2019) formulated a mixed-integer optimization problem with an objective function formulated as the weighted sum of transmission time and content hit number. By using matching theory and Autoregressive Integrated Moving Average (ARIMA) method, an iterative algorithm was proposed to solve the joint problem. Compared with a conventional network, the proposed scheme brings up to 82% performance improvement. With the assumption that cache-enabled IAB nodes have three different backhaul options: (1) wired fiber, (2) mmWave wireless backhaul, and (3) sub-6 GHz wireless backhaul, the authors proposed a game-theoretic learning algorithm to solve the content caching problem in (Hamidouche et al., 2017). A minority game was formulated, where IAB nodes act as players with independent decisions for backhaul option choice and types of caching the contents. In comparison with the greedy algorithm, the proposed scheme can achieve up to 85% performance improvement.

Both (Haw et al., 2019) and (Hamidouche et al., 2017) assumed that the content popularity is stable over time, this assumption could lead to performance degradation in reality when the content popularity is unpredictable. In this context, with the consideration of dynamic content popularity, the authors in (Blasco and Gunduz, 2014) proposed a learning

algorithm based on multi-armed bandit (MAB) theory to maximize the bandwidth alleviation for backhaul links. The proposed algorithm is able to learn the content placement decision without the need for file popularity information. In comparison with the random cache method, the proposed algorithm can achieve performance improvement of up to 7 times. By introducing a virality parameter to represent the change of users' content requests over time, the authors in (Ahangary et al., 2020) studied the cached content placement problem in a mmWave IAB network. Moreover, a hierarchical caching architecture was considered, where the IAB donor and IAB nodes store different finite kinds of contents. The request for content stored in the central storage server will be forwarded by the IAB donor *via* a wireless backhaul. In order to minimize backhaul load and average delay, the authors proposed a heuristic method to derive the optimal content placement decision. Simulation results showed that the proposed method can achieve improvement for hit probability by 23% and reduction in backhaul load and average delay by 48 and 27%.

The coded cooperation of cache-enabled IAB nodes was considered in (Gao et al., 2020) and (Vu et al., 2018). The authors in (Vu et al., 2018) studied the energy-efficiency performance of a cache-enabled IAB network, with the consideration of the cache capability. Simulation results showed that uncoded caching outperforms coded caching in the small user cache size regime, while coded caching outperforms uncoded caching in the small BSs cache size regime. In (Gao et al., 2020), the authors applied the maximum distance separable (MDS) code at the IAB nodes. By leveraging the Q-learning model, the content caching decision is derived. Compared with the DDPG method, the proposed method can reduce the time complexity significantly. The energy efficiency maximization problem in a FD cache-enabled IAB network was addressed in (Vu et al., 2020). The authors investigated two collaboration schemes among the edge BSs : (1) distributed caching-separate access transmission and (2) cooperative caching-joint access transmission. The edge BSs are operated in the FD mode. By optimal precoding design, numerical results showed that the cooperative caching scheme outperforms the distributed scheme.

6.3. Section Summary

The comparison of the studies related to the performance analysis and the caching strategy design for cache-enabled IAB networks is shown in **Table 4**. The authors in (Wang et al., 2018) and Zhang X. et al. (2019) have proved that the hit probability has an important impact on the performance of cache-enabled IAB networks. Most existing works aim at designing the optimal content placement policy, however, the optimization for storage size is disregarded. In general, the BS with a larger storage size implies that more contents can be cached, and the hit probability will increase. The allocation of caching storages is still an open issue in the cache-enabled IAB networks.

7. OPTICAL IAB NETWORKS

Optical wireless communication (OWC) using wavelength band ranges from 350 nm to 1550 nm is a promising alternative

TABLE 4 | Taxonomy of literature in section 6.

Objective	Methodology	Network	References
SCDP analysis	Stochastic geometry	massive MIMO, OBFD, Caching	Wang et al. (2018)
ASP analysis		IBFD, mmWave, Caching	Zhang T. et al. (2019)
Throughput analysis		OBFD, mmWave, Caching	Zhang C. et al. (2020)
Caching strategy design	Matching theory, ARIMA	Single-hop backhaul	Haw et al. (2019)
	MAB-based learning	Unknown content popularity	Blasco and Gunduz (2014)
	Game theory, RL	Hybrid mmWave & Sub-6 Ghz	Hamidouche et al. (2017)
	DRL	MDS-coded caching	Gao et al. (2020)
	Heuristic algorithm	mmWave	Ahangary et al. (2020)

solution to RF transmission (Ghassemlooy et al., 2015). This section reviews the studies for the incorporation of visible light communication (VLC) and free-space optical (FSO) communication into the IAB networks, respectively.

7.1. Visible Light Communication

In VLC, the transmission is based on the modulation of the intensity of the optical source, which uses the visible range of electromagnetic spectrum (Wu et al., 2020). Due to the energy-efficient benefit and long lifetime, light-emitting diode (LED) is widely used in indoor illumination. The authors in (Kazemi et al., 2017) developed an analytical framework to investigate SINR and average spectral efficiency in a hexagonal VLC-based IAB network. Moreover, the effect of employing in-band and out-band wireless backhaul was studied. Compared with out-band backhaul, it was shown that the in-band mode can achieve better performance when the emission semiangle exceeds 25° or falls below 20°. The work in (Kazemi et al., 2017) is extended in (Kazemi et al., 2019) to a two-tier multi-hop wireless backhaul scenario. For that setup, the authors derived the power control policy by solving the backhaul transmitting power consumption minimization problem. It was shown that, in terms of average sum rate, a small value of the emission semiangle can achieve better performance, and in-band mode significantly outperforms out-band mode.

The joint backhaul spectrum resource and transmitting power allocation problem was addressed in (Kazemi et al., 2018). The authors first derived the analytical expressions for access and backhaul rate, and then used it to obtain the power and spectrum allocation coefficients under the backhaul capacity requirement. From an optimization perspective, in (Kazemi et al., 2020), based on projected subgradient method, with the aim to maximize the sum rate of mobile users and the IAB nodes, user-centric and cell-centric backhaul spectrum scheduling policies were derived

for the considered two-tier multi-hop VLC-based IAB network. By integrating the RF transmission with VLC, the authors in (Murugaveni and Mahalakshmi, 2020) considered a hybrid network with RF-based IAB donor and VLC-based IAB nodes. In particular, the IAB node employed NOMA to improve spectral efficiency. With the objective to minimize the interference, a heuristic algorithm was proposed to obtain the bandwidth reuse decision among the IAB nodes. Simulation results showed that the proposed dynamic scheme can achieve performance improvement in both sum rate and spectrum efficiency.

7.2. Free-Space Optical

Free-space optical enables high capacity transmission between access points (APs) that are separated by several kilometers, with a frequency that is above 300 GHz (Khalighi and Uysal, 2014; Trichili et al., 2020). Therefore, FSO communication is an attractive option for coping with the increased communication traffic demands especially in the outdoor environment (Alzenad et al., 2018). However, one of the inherent difficulties for FSO communication is the requirement for a reliable LoS. In (Gu et al., 2018), the authors first proposed a greedy algorithm to optimize the network sum rate and overall power cost and to obtain the policies for connecting path and routing. Moreover, two network reconfiguration solutions to deal with the link failure and dynamic traffic demand change were proposed, respectively. In order to improve the reliability, the authors in (Li Y. et al., 2015) considered the usage of the mirror-aided links to ensure the connectivity of two distinct nodes when their LoS is blocked. For the formulated graph optimization problem with the aim to minimize the sum of weighted cost and reliable link length, they proposed a sequential computation algorithm to obtain the connecting paths as well as the number and locations of mirrors, IAB donors, and FSO transceivers. Based on a realistic topology model, the simulation results showed that the proposed method can achieve optimal or near-optimal performance with much lower time complexity.

The authors in (Atakora and Chenji, 2018) considered an IAB network where the IAB donor is equipped with a FSO transceiver. With the objective to minimize the overall delay under the requirement of all IAB nodes, they solved the multicast problem for IAB nodes when they are static or mobile. By reformulating the problem as a time-dependent prize collecting traveling salesman problem, the authors proposed several heuristic algorithms to find the optimal scheduling of the directional optical links. A hybrid RF/FSO UL transmission for IAB networks was studied in (Jamali et al., 2016), where there are two types of links in the wireless backhaul. In particular, the authors considered two transmission schemes at the IAB nodes: (1) delay-tolerant, where it can store the received information packets and forward them later; (2) delay-limited, where it forwards the received signal immediately. By solving the throughput maximization problem *via* Lagrange dual decomposition method, the optimal UL block resource allocation policy was derived. Simulation results showed that sharing block resources is required to improve the throughput when the quality of FSO links falls below a certain level.

TABLE 5 | Taxonomy of literature in section 7.

Objective	Methodology	Network	References
Interference mitigation	Heuristic algorithm	VLC & NOMA	Murugaveni and Mahalakshmi (2020)
Power consumption minimization & SINR analysis	Projected subgradient & Stochastic analysis	VLC	Kazemi et al. (2017, 2019)
Throughput maximization	Lagrange dual decomposition	FSO	Kazemi et al. (2018, 2020) Jamali et al. (2016)
Routing	Heuristic algorithm		Gu et al. (2018)
Delay minimization			Atakora and Chenji (2018)
Deployment design	Sequential computation		Li Y. et al. (2015)

7.3. Section Summary

This section introduces and compares literature for the integration of IAB to the optical transport networks. The taxonomy for the literature according to the network model and the technique is shown in **Table 5**. In comparison to RF transport networks, the OWC system has a very high optical bandwidth resource. Hence, by exploiting the much larger bandwidth, it is less expensive to perform self-backhauling in the optical IAB networks than in the RF counterparts. As a possible non-3GPP research extension, in the optical IAB networks, the OWC links can be deployed between the BSs and the mobile switching center to enable a much higher backhaul throughput. As for the access links in the optical IAB networks, OWC links are only provided for the end users which can be equipped with optical transmitter and receiver, such as video-surveillance devices. The hybrid architecture consisting OWC and RF in the IAB networks can overcome the limitations of individual networks. Therefore, hybrid OWC/RF IAB networks are emerged as a promising solution for high-data-rate wireless communication systems.

8. NON-TERRESTRIAL IAB NETWORKS

Providing global connectivity is not a new ambition (Yaacoub and Alouini, 2020). To this end, satellite and unmanned aerial vehicle (UAV) are attractive options to offer communication service over the areas that are too expensive to reach or too difficult to deploy conventional terrestrial networks (e.g., rural and remote regions and marine area) (Kishk et al., 2020; Talgat et al., 2020). This section focuses on the research related to the non-terrestrial IAB networks. We classify these papers into two categories: (i) UAV-assisted IAB networks and (ii) satellite-terrestrial IAB networks.

8.1. Unmanned Aerial Vehicle-Assisted IAB Networks

Due to the ability to their mobility and relocation flexibility, UAV-BSs could be deployed at any three-dimensional (3D) position of interest. However, due to the non-negligible multipath propagation and link blockage in a realistic environment, one

important issue in a UAV-assisted network is the optimization of UAV-BSs positions. In (Perez et al., 2019), based on ray-tracing simulations, the authors first investigated the coverage gains of UAV-assisted mmWave IAB network, where the UAV-BSs act as IAB nodes. With the consideration of amplify-and-forward (AF) OBF and decode-and-forward (DF) IBFD modes, the optimal positions for UAVs were derived *via* the ray tracing-based coverage maps. The simulation results showed that the AF mode outperforms the DF mode with 31% DL coverage gains improvement.

Zhang et al. addressed the joint optimization problem for the number and 3D positions of UAV-BSs in an IBFD UAV-assisted IAB network (Zhang and Ansari, 2019). A heuristic algorithm was proposed to solve the optimization problem which aims to minimize the number of UAVs while maximizing the overall transmission rate. Numerical results proved that the proposed algorithm can not only increase the overall throughput but also can decrease data rate block ratio. In (Kalantari et al., 2017), the authors solved the UAV-BSs placement problem in order to maximize the sum rate and the number of served mobile users. Moreover, the effect of the movement of mobile users was investigated in the simulations. Simulation results showed that the proposed method can achieve robust performance under the impact of users' mobility. By defining a piecewise-linear function of gained transmission rate that captures the profit of mobile users, the authors in (Cicek et al., 2020) addressed the joint UAV-BS position and bandwidth allocation optimization problem. In order to maximize the total network profit, they proposed a heuristic algorithm to solve the formulated mixed-integer non-linear programming problem. Numerical results showed that the proposed solution is able to significantly outperform the well-known BARON solver (Tawarmalani and Sahinidis, 2004) and the network-enabled optimization system (NEOS) platform (Czyzyk et al., 1998).

In a realistic environment, the dynamic change for both the multipath propagation and link blockage are non-negligible. The authors in (Gapeyenko et al., 2018) developed analytical frameworks to characterize the performance of a UAV-assisted mmWave IAB network with terrestrial BSs (TBSs) and UAV-BSs. With the consideration of the dynamic mobility of human blockers and UAV-BSs, the time-averaged and time-dependent performance metrics were derived. It was shown that both outage probability (OP) and spectrum efficiency were improved as the intensity of UAV-BSs traversals increases. In addition, it was also shown that the lower flight speed can achieve a better wireless backhaul performance. The authors in (Zhang J. et al., 2020) considered a maritime communication system with cache-enabled UAV-BSs. The optimal horizontal positions of UAV-BSs were obtained by an iterative one-dimensional linear search algorithm to maximize the sum rate. In (Khuwaja et al., 2020), the authors investigated the incorporation of cache-enabled UAV-BSs into an terrestrial cache-enabled IAB network. A tractable model for characterizing SCDP and energy efficiency was developed. Simulation results showed that the considered scheme can achieve 26.6% SCDP performance improvement on average.

The path selection problem for a UAV-assisted multi-hop IAB network was addressed in (Almohamad et al., 2018). The authors

formulated and solved a binary linear optimization program aiming at maximizing the total transmission rate and obtaining the optimal path scheduling policy. By integrating UAVs as drone BSs into the IAB network, Fouda et al. (2018) presented a system model for forward link transmissions in an in-band IAB HetNet. Given that the backhaul link to the UAVs is provided by the IAB donor, an optimization problem is formulated that aims to achieve the maximum sum rate of the users, under the constraints that the mutual interference between access and backhaul links is below a given threshold. By using an alternative optimization method, the authors derived the optimal 3D hovering positions of the UAVs, mobile users association policy, precoder design at the backhaul link, and transmitting power allocation policy. Further, a better performance algorithm based on particle swarm optimization (PSO) is proposed in (Fouda et al., 2019).

8.2. Satellite-Terrestrial IAB Networks

One advantage of satellite-terrestrial communication is that it enables the network operators to cover wider areas at a lower cost. There are several on-going satellite-terrestrial communication projects, such as SpaceX and OneWeb, aiming to provide global-coverage and high data rates *via* low earth orbit satellite (LEO) networks. In this context, the design of satellite-terrestrial backhaul link plays a key role in the service quality of users (Artiga et al., 2018).

The authors in (Lagunas et al., 2017b) addressed the spectrum resource allocation problem for the DL transmission in a satellite-terrestrial IAB network. The considered system assumes the terrestrial links, and the satellite links can reuse the same frequency. By decomposing the sum rate maximization problem into two sub-problems, the optimal carrier allocation strategy was derived by the Hungarian method sequentially. In (Di et al., 2018), a satellite-terrestrial IAB network architecture for data offloading was studied. The satellite-terrestrial backhaul links share the Ka-band while the terrestrial links share the C-band. Terrestrial mobile users have access to the core network through the macro-cell, the small-cell, or the LEO-based small-cell. With the aim to maximize the sum rate, the authors proposed a modified swap matching algorithm to obtain the optimal policies for users association, subchannel allocation, and power control. Simulation results revealed that the total capacity is not a monotonic function of the projected area of the satellite, which means that there exists an optimal satellite deployment solution to maximize the total backhaul capacity.

With the application of the game theory model into a satellite-terrestrial IAB network, the authors in (Deng et al., 2020) proposed a data offloading pricing mechanism based on the Stackelberg game model. To deal with the increasing backhaul demand at conventional APs, they assumed some user's demand from conventional APs can be migrated to LEO-based APs. In this context, the LEO-based APs act as the leaders while the conventional APs act as the followers. An iterative algorithm was proposed to reach the Stackelberg equilibrium. In each iteration, the follower level optimization problem aims at optimizing user association by fractional programming, and then the leader level problem with the aim to optimize the service price and Ka-band spectrum allocation is solved by alternative optimization. The

TABLE 6 | Taxonomy of literature in section 8.

Objective	Methodology	Network	References
Deployment design	Ray tracing	UAV-terrestrial	Perez et al. (2019)
	Heuristic algorithm		Zhang and Ansari (2019) Kalantari et al. (2017) Cicek et al. (2020)
SCDP analysis	Linear search	UAV-marine	Zhang J. et al. (2020)
	Stochastic geometry	Cache-enabled UAV	Khuwaja et al. (2020)
OP analysis		UAV-terrestrial	Gapeyenko et al. (2018)
Routing	Linear programming		Almohamad et al. (2018)
	Heuristic algorithm		Fouda et al. (2018, 2019)
Throughput maximization	Hungarian method	Satellite-terrestrial	Lagunas et al. (2017b)
	Swap matching		Di et al. (2018)
Incentive mechanism	Game theory	Satellite-aerial-terrestrial	Deng et al. (2020) Hu et al. (2020)

simulation results showed that there is an optimal LEO satellite density to balance the trade-off between APs utility and cost.

In addition to the application of the game theory model, the integration of UAV and satellite-terrestrial IAB networks was investigated in (Hu et al., 2020). The IAB nodes consist of the satellite, terrestrial SBSs, and UAVs, while the IAB donor is the MBS. This joint backhaul and access resource management problem was formulated as a competitive market. Hu et al. assumed that some UAVs, satellite, some SBSs, and MBSs act as “sellers”, where others UAV and SBSs act as “customers.” The communication services were regarded as “goods,” and their prices are determined by the QoS, while the cost is determined by the power consumption. The network seeks to achieve the Walrasian equilibrium, at which there are no good exits, and each role’s profit is maximized. The simulation results showed that the proposed algorithm can reach the Walrasian equilibrium within 200 iterations. Compared to random allocation, the proposed algorithm achieved 3 to 4 times gain in the data rate.

8.3. Section Summary

The comparison of the studies focusing on the non-terrestrial IAB networks is shown in **Table 6**. The related studies aim at achieving economic wide-area connectivity, which can be classified into UAV-assisted and satellite-terrestrial IAB networks. Non-terrestrial networks and IAB networks have been defined by 3GPP separately (3GPP, 2018, 2020b). However, the integration of these two technologies is not standardized yet. The integration of non-terrestrial networks and IAB emerges as a promising solution for providing service in the area where optic fiber cables are not available. Notably, the performance of non-terrestrial IAB networks is affected by some individual characteristics of non-terrestrial networks, such as long propagation distance and movement of aerial BSs. As a result, the network deployment design will be an important issue in the non-terrestrial IAB networks.

9. CHALLENGES AND OPPORTUNITIES

The existing literature presented various promising solutions to improve the performance of the IAB networks. In order to exploit the full potential of IAB networks, the flexible integration of IAB networks with other advanced techniques may achieve even more success in the next generation communication system. The OWC links can be applied into the backhaul links in the cache-enabled and non-terrestrial IAB networks to improve the backhaul throughput, and the non-terrestrial IAB networks can adopt cache-enabled BSs to reduce the probability of requesting content from the remote server. For example, in a non-terrestrial IAB network with multiple drone BSs, we can consider adopting FSO links for the drone BS to drone BS links in order to achieve a higher data rate and reduce the inter-interference. In particular, we discuss the challenges and possible opportunities on the deployment, scheduling, mobility management, and intelligent.

9.1. Integrated Access and Backhaul Deployment

In reality, the height of the blockages and the terrain information cannot be negligible for the UHF channel. Therefore, the 3D positions should be considered in the IAB deployment. Moreover, the interaction among different layers of the protocol stack remains a design challenge for IAB. Thus, designing a more realistic and efficient deployment solution for improving the end-to-end performance is still worthy research.

9.2. Scheduling

Directed acyclic graph and ST limit the flexibility and efficiency due to the fixed parent-to-child relation between two adjacent IAB nodes. Studies in both (Zhai et al., 2020) and (Islam et al., 2018) proved that mesh-architecture based IAB achieves a considerable improvement in comparison to DAG-architecture based IAB. It is expected that mesh-architecture-based IAB will be introduced in the Rel-17. The solution to address congestion control and routing will be important in mesh-architecture-based IAB.

9.3. Mobility Management

Due to the usage of higher frequencies, the wireless backhaul link in IAB is vulnerable to mobility blockage (e.g., vehicles and human movements). Therefore, from a resilience perspective, it is desired to ensure that an IAB network can provide reliable services to end-users when some backhaul links are degraded or lost.

9.4. Intelligent IAB

In IAB, the relation between access and backhaul will be closer than ever. Therefore, joint operation is required since total separation of their resources might not be possible. A crucial issue in operator maintenance is the designing of a mechanism for realizing an intelligent access-demand-aware backhaul system in which a central or distributed controller

optimizes the backhaul capacity according to dynamic access network demand.

10. CONCLUSIONS

Integrated access and backhaul provides an economical and flexible network deployment solution in the era of 5G and beyond network densification. In this study, a brief introduction to IAB was followed by a discussion and comparison of recent research works on IAB networks. In addition, state-of-the-art studies on integrated IAB with cache-enabled, optical transport, and non-terrestrial communication networks were reviewed. Finally, the possible challenges and opportunities in this promising research area were described.

REFERENCES

- 3GPP (2016). *Overview of 3GPP Release 10*. Technical report, 3GPP. v10.2.1.
- 3GPP (2018). *NR; Study on Integrated Access and Backhaul; Release 15*. TR 38.874, 3GPP.
- 3GPP (2020a). *NG-RAN; Architecture description*. TS 38.401, 3GPP. v16.2.0.
- 3GPP (2020b). *Solutions for NR to Support Non-Terrestrial Networks; Release 16*. TR 38.821, 3GPP.
- Agiwal, M., Roy, A., and Saxena, N. (2016). Next generation 5G wireless networks: a comprehensive survey. *IEEE Commun. Surv. Tuts* 18, 1617–1655. doi: 10.1109/COMST.2016.2532458
- Ahangary, S., Chitsaz, H., Sobouti, M. J., Mohajerzadeh, A. H., Yaghmaee, M. H., and Ahmadi, H. (2020). “Reactive caching of viral content in 5G networks,” in *Proceeding of 3rd International Conference on Advanced Communication Technologies and Networking (CommNet)* (Marrakech: IEEE).
- Almohamad, A., Hasna, M. O., Khattab, T., and Haouari, M. (2018). “Maximizing dense network flow through wireless multihop backhauling using UAVs,” in *Proceeding of International Conference on Information and Communication Technology Convergence (ICTC)* (Jeju: IEEE).
- Alzenad, M., Shakir, M. Z., Yanikomeroglu, H., and Alouini, M.-S. (2018). FSO-based vertical backhaul/fronthaul framework for 5G+ wireless networks. *IEEE Commun. Mag.* 56, 218–224. doi: 10.1109/MCOM.2017.1600735
- Andrews, M., Ghosh, A., Pupala, R. N., and Vasudevan, S. (2017). Performance evaluation of self backhauled small cell heterogeneous networks. *IEEE Trans. Wireless Commun.* 16, 3102–3110. doi: 10.1109/TWC.2017.2675400
- Artiga, X., Perez-Neira, A., Baranda, J., Lagunas, E., Chatzinotas, S., Zetik, R., et al. (2018). Shared access satellite-terrestrial reconfigurable backhaul network enabled by smart antennas at mmWave band. *IEEE Netw.* 32, 46–53. doi: 10.1109/MNET.2018.1800030
- Atakora, M., and Chenji, H. (2018). A multicast technique for fixed and mobile optical wireless backhaul in 5G networks. *IEEE Access* 6, 27491–27506. doi: 10.1109/ACCESS.2018.2832980. [Epub ahead of print].
- Baker, M., and Poikselk, a, M. (2020). *5G Releases 16 and 17 in 3GPP: White paper*. Espoo: Bell Labs.
- Bande, M., and Veeravalli, V. V. (2020). Design of a heterogeneous cellular network with a wireless backhaul. *IEEE Trans. Wireless Commun.* 20, 243–253. doi: 10.1109/TWC.2020.3024272
- Bharadia, D., McMilin, E., and Katti, S. (2013). “Full duplex radios,” in *Proceeding of ACM SIGCOMM* (Hong Kong), 375–386.
- Bhushan, N., Li, J., Malladi, D., Gilmore, R., Brenner, D., Damnjanovic, A., et al. (2014). Network densification: the dominant theme for wireless evolution into 5G. *IEEE Commun. Mag.* 52, 82–89. doi: 10.1109/MCOM.2014.6736747
- Blasco, P., Bennis, M., and Dohler, M. (2013). “Backhaul-aware self-organizing operator-shared small cell networks,” in *Proceeding of IEEE International Conference on Communications (ICC)* (Budapest).
- Blasco, P., and Gunduz, D. (2014). “Learning-based optimization of cache content in a small cell base station,” in *Proceeding of IEEE International Conference on Communications (ICC)* (Sydney, NSW).

AUTHOR CONTRIBUTIONS

This work was developed as a collaboration among all authors. All authors conceived the work and suggested the outline of the paper. The manuscript was mainly drafted by YZ and was revised and corrected by all co-authors. All authors have read and approved the final manuscript.

FUNDING

This work was supported by the Office of Sponsored Research (OSR) at the King Abdullah University of Science and Technology (KAUST).

- Bonfante, A., Giordano, L. G., Lopez-Perez, D., Garcia-Rodriguez, A., Geraci, G., Baracca, P., et al. (2018). “Performance of massive MIMO self-backhauling for ultra-dense small cell deployments,” in *Proceeding of IEEE Global Communications Conference (GLOBECOM)* (Abu Dhabi).
- Chaudhry, A. U., Jacob, N., George, D., and Hafez, R. H. (2020). “On the interference range of small cells in the wireless backhaul of 5G ultra-dense networks,” in *Proceeding of Wireless Telecommunications Symposium (WTS)* (Washington, DC: IEEE).
- Chen, E., Tao, M., and Zhang, N. (2018). “User-centric joint access-backhaul design for full-duplex self-backhauled cooperative networks,” in *Proceeding of IEEE Global Communications Conference (GLOBECOM)* (Abu Dhabi).
- Chen, E., Tao, M., and Zhang, N. (2019). User-centric joint access-backhaul design for full-duplex self-backhauled wireless networks. *IEEE Trans. Commun.* 67, 7980–7993. doi: 10.1109/TCOMM.2019.2932987
- Chen, L., Yu, F. R., Ji, H., Leung, V. C., Li, X., and Rong, B. (2016a). “A full-duplex self-backhaul scheme for small cell networks with massive MIMO,” in *Proceeding of IEEE International Conference on Communications (ICC)* (Kuala Lumpur).
- Chen, L., Yu, F. R., Ji, H., Liu, G., and Leung, V. C. M. (2016b). Distributed virtual resource allocation in small-cell networks with full-duplex self-backhauls and virtualization. *IEEE Trans. Veh. Technol.* 65, 5410–5423. doi: 10.1109/TVT.2015.2469149
- Chen, L., Yu, F. R., Ji, H., Rong, B., Li, X., and Leung, V. C. M. (2016c). Green full-duplex self-backhaul and energy harvesting small cell networks with massive MIMO. *IEEE J. Sel. Areas Commun.* 34, 3709–3724. doi: 10.1109/JSAC.2016.2611846
- Cicek, C. T., Gultekin, H., Tavli, B., and Yanikomeroglu, H. (2020). Backhaul-aware optimization of UAV base station location and bandwidth allocation for profit maximization. *IEEE Access* 8, 154573–154588. doi: 10.1109/ACCESS.2020.3018861
- Czegledi, C. B., Horberg, M., Sjodin, M., Ligander, P., Hansryd, J., Sandberg, J., et al. (2020). “Demonstrating 139 Gbps and 55.6 bps/Hz spectrum efficiency using 8×8 MIMO over a 1.5-km link at 73.5 GHz,” in *Proceeding of IEEE/MTT-S International Microwave Symposium (IMS)* (Los Angeles, CA).
- Czyzyk, J., Mesnier, M., and More, J. (1998). The NEOS server. *IEEE Comput. Sci. Eng.* 5, 68–75. doi: 10.1109/99.714603
- Dahlman, E., Parkvall, S., and Skold, J. (2020). *5G NR: The Next Generation Wireless Access Technology, 2nd Edn*. San Diego, CA: Academic Press.
- Dang, S., Amin, O., Shihada, B., and Alouini, M.-S. (2020). What should 6G be? *Nat. Electron.* 3, 20–29. doi: 10.1038/s41928-019-0355-6
- Dehos, C., González, J. L., De Domenico, A., Ktenas, D., and Dussopt, L. (2014). Millimeter-wave access and backhauling: the solution to the exponential data traffic increase in 5G mobile communications systems? *IEEE Commun. Mag.* 52, 88–95. doi: 10.1109/MCOM.2014.6894457
- Deng, R., Di, B., Chen, S., Sun, S., and Song, L. (2020). Ultra-dense LEO satellite offloading for terrestrial networks: how much to pay the satellite operator? *IEEE Trans. Wireless Commun.* 19, 6240–6254. doi: 10.1109/TWC.2020.3001594

- Di, B., Zhang, H., Song, L., Li, Y., and Li, G. Y. (2018). "Data offloading in ultra-dense LEO-based integrated terrestrial-satellite networks," in *Proceeding of IEEE Global Communications Conference (GLOBECOM)* (Abu Dhabi).
- Duarte, M., and Sabharwal, A. (2010). "Full-duplex wireless communications using off-the-shelf radios: feasibility and first results," in *Proceeding of IEEE Conference Record of the Forty Fourth Asilomar Conference on Signals, Systems and Computers* (Pacific Grove, CA).
- ElSawy, H., Hossain, E., and Haenggi, M. (2013). Stochastic geometry for modeling, analysis, and design of multi-tier and cognitive cellular wireless networks: a survey. *IEEE Commun. Surv. Tuts* 15, 996–1019. doi: 10.1109/SURV.2013.052213.00000
- Ericsson (2020a). *Integrated Access and Backhaul – A New Type of Wireless Backhaul in 5G*. Available online at: <https://www.ericsson.com/en/reports-and-papers/ericsson-technology-review/articles/introducing-integrated-access-and-backhaul>.
- Ericsson (2020b). *Mobile Data Traffic Growth Outlook*. Available online at: <https://www.ericsson.com/en/mobilityreport/reports/november-2018/mobile-data-traffic-growth-outlook>.
- Favraud, R., Nikaiein, N., and Chang, C.-Y. (2017). "QoS guarantee in self-backhauled LTE mesh networks," in *Proceeding of IEEE Global Communications Conference* (Singapore).
- Fouda, A., Ibrahim, A. S., Guvenc, I., and Ghosh, M. (2018). "UAV-based in-band integrated access and backhaul for 5G communications," in *Proceeding IEEE Vehicular Technology Conference (VTC-Fall)* (Chicago, IL), 1–5.
- Fouda, A., Ibrahim, A. S., Guvenc, I., and Ghosh, M. (2019). Interference management in UAV-assisted integrated access and backhaul cellular networks. *IEEE Access* 7, 104553–104566. doi: 10.1109/ACCESS.2019.2927176
- Fragouli, C., Widmer, J., and Le Boudec, J.-Y. (2006). "On the benefits of network coding for wireless applications," in *Proceeding of 4th International Symposium on Modeling and Optimization in Mobile, Ad Hoc and Wireless Networks* (Boston, MA: IEEE), 1–6.
- Gao, S., Dong, P., Pan, Z., and Li, G. Y. (2020). Reinforcement learning based cooperative coded caching under dynamic popularities in ultra-dense networks. *IEEE Trans. Veh. Technol.* 69, 5442–5456. doi: 10.1109/TVT.2020.2979918
- Gapeyenko, M., Petrov, V., Moltchanov, D., Andreev, S., Himayat, N., and Koucheryavy, Y. (2018). Flexible and reliable UAV-assisted backhaul operation in 5G mmWave cellular networks. *IEEE J. Sel. Areas Commun.* 36, 2486–2496. doi: 10.1109/JSAC.2018.2874145
- Ge, X., Li, X., Jin, H., Cheng, J., and Leung, V. C. M. (2018). Joint user association and user scheduling for load balancing in heterogeneous networks. *IEEE Trans. Wireless Commun.* 17, 3211–3225. doi: 10.1109/TWC.2018.2808488
- Ghassemlooy, Z., Arnon, S., Uysal, M., Xu, Z., and Cheng, J. (2015). Emerging optical wireless communications—advances and challenges. *IEEE J. Sel. Areas Commun.* 33, 1738–1749. doi: 10.1109/JSAC.2015.2458511
- Gomez-Cuba, F., and Zorzi, M. (2020a). Optimal link scheduling in millimeter wave multi-hop networks with MU-MIMO radios. *IEEE Trans. Wireless Commun.* 19, 1839–1854. doi: 10.1109/TWC.2019.2959295
- Gomez-Cuba, F., and Zorzi, M. (2020b). "Twice simulated annealing resource allocation for mmWave multi-hop networks with interference," in *Proceeding of IEEE International Conference on Communications (ICC)* (Dublin).
- Goyal, S., Liu, P., and Panwar, S. (2017). "Scheduling and power allocation in self-backhauled full duplex small cells," in *2017 IEEE International Conference on Communications (ICC)* (Paris).
- Gu, Z., Zhang, J., Ji, Y., Bai, L., and Sun, X. (2018). Network topology reconfiguration for FSO-based fronthaul/backhaul in 5G+ wireless networks. *IEEE Access* 6, 69426–69437. doi: 10.1109/ACCESS.2018.2880880
- Gupta, M., Rao, A., Visotsky, E., Cudak, M., Ghosh, A., and Andrews, J. G. (2019). "Learning-based delay optimization for self-backhauled millimeter wave cellular networks," in *2019 53rd Asilomar Conference on Signals, Systems, and Computers* (Pacific Grove, CA: IEEE).
- Hajek, B., and Sasaki, G. (1988). Link scheduling in polynomial time. *IEEE Trans. Inform. Theor.* 34, 910–917.
- Hamidouche, K., Saad, W., Debbah, M., Song, J. B., and Hong, C. S. (2017). The 5G cellular backhaul management dilemma: to cache or to serve. *IEEE Trans. Wireless Commun.* 16, 4866–4879. doi: 10.1109/TWC.2017.2702559
- Haw, R., Kazmi, S. M. A., Thar, K., Alam, M. G. R., and Hong, C. S. (2019). Cache aware user association for wireless heterogeneous networks. *IEEE Access* 7, 3472–3485. doi: 10.1109/ACCESS.2018.2885571
- Hu, Y., Chen, M., and Saad, W. (2020). Joint access and backhaul resource management in satellite-drone networks: a competitive market approach. *IEEE Trans. Wireless Commun.* 19, 3908–3923. doi: 10.1109/TWC.2020.2979127
- Hui, D., and Axsas, J. (2013). "Joint routing and resource allocation for wireless self-backhaul in an indoor ultra-dense network," in *Proceeding of IEEE Annual International Symposium on Personal, Indoor, and Mobile Radio Communications (PIMRC)* (London).
- Imran, A., Giupponi, L., Imran, M. A., and Abu-Dayya, A. (2014). "Joint coverage and backhaul self-optimization in emerging relay enhanced heterogeneous networks," in *Proceeding of IEEE International Conference on Communications (ICC)* (Sydney, NSW).
- Iqbal, M. A., Dai, B., Huang, B., Hassan, A., and Yu, S. (2011). Survey of network coding-aware routing protocols in wireless networks. *J. Netw. Comput. Appl.* 34, 1956–1970. doi: 10.1016/j.jnca.2011.07.012
- Islam, M. N., Abedini, N., Hampel, G., Subramanian, S., and Li, J. (2018). "Investigation of performance in integrated access and backhaul networks," in *Proceeding of IEEE Conference on Computer Communications Workshops* (Honolulu, HI), 597–602.
- Islam, M. N., Subramanian, S., and Sampath, A. (2017). "Integrated access backhaul in millimeter wave networks," in *Proceeding of IEEE Wireless Communications and Networking Conference (WCNC)* (San Francisco, CA), 1–6.
- Jain, R. K., Chiu, D.-M. W., and Hawe, W. R. (1984). *A Quantitative Measure of Fairness and Discrimination*. Hudson, MA: Eastern Research Laboratory, Digital Equipment Corporation.
- Jamali, V., Michalopoulos, D. S., Uysal, M., and Schober, R. (2016). Link allocation for multiuser systems with hybrid RF/FSO backhaul: delay-limited and delay-tolerant designs. *IEEE Trans. Wireless Commun.* 15, 3281–3295. doi: 10.1109/TWC.2016.2519508
- Jayasinghe, P., Tölli, A., Kaleva, J., and Latva-aho, M. (2020). "Traffic aware beamformer design for integrated access and backhaul with flexible TDD," in *Proceeding of IEEE Wireless Communications and Networking Conference (WCNC)* (Seoul), 1–6.
- Kalantari, E., Shakir, M. Z., Yanikomeroglu, H., and Yongacoglu, A. (2017). "Backhaul-aware robust 3D drone placement in 5G+ wireless networks," in *Proceeding of IEEE International Conference on Communications Workshops (ICC Workshops)* (Paris).
- Kazemi, H., Safari, M., and Haas, H. (2017). "A wireless backhaul solution using visible light communication for indoor li-fi attocell networks," in *Proceeding of IEEE International Conference on Communications (ICC)* (Paris).
- Kazemi, H., Safari, M., and Haas, H. (2018). "Bandwidth scheduling and power control for wireless backhauling in optical attocell networks," in *Proceeding of IEEE Global Communications Conference (GLOBECOM)* (Abu Dhabi).
- Kazemi, H., Safari, M., and Haas, H. (2019). A wireless optical backhaul solution for optical attocell networks. *IEEE Trans. Wireless Commun.* 18, 807–823. doi: 10.1109/TWC.2018.2883465
- Kazemi, H., Safari, M., and Haas, H. (2020). Multi-hop wireless optical backhauling for LiFi attocell networks: bandwidth scheduling and power control. *IEEE Trans. Wireless Commun.* 19, 5676–5691. doi: 10.1109/TWC.2020.2995341
- Kelly, F. (1997). Charging and rate control for elastic traffic. *Eur. Trans. Telecommun.* 8, 33–37.
- Khalighi, M. A., and Uysal, M. (2014). Survey on free space optical communication: a communication theory perspective. *IEEE Commun. Surv. Tuts* 16, 2231–2258. doi: 10.1109/COMST.2014.2329501
- Khuwaja, A. A., Zhu, Y., Zheng, G., Chen, Y., and Liu, W. (2020). Performance analysis of hybrid UAV networks for probabilistic content caching. *IEEE Syst. J.* doi: 10.1109/jsyst.2020.3013786. [Epub ahead of print].
- Kim, D., Lee, H., and Hong, D. (2015). A survey of in-band full-duplex transmission: from the perspective of PHY and MAC layers. *IEEE Commun. Surv. Tuts* 17, 2017–2046. doi: 10.1109/COMST.2015.2403614
- Kishk, M., Bader, A., and Alouini, M.-S. (2020). Aerial base station deployment in 6G cellular networks using tethered drones: the mobility and endurance tradeoff. *IEEE Veh. Technol. Mag.* 15, 103–111. doi: 10.1109/MVT.2020.3017885

- Korpi, D., Riihonen, T., Sabharwal, A., and Valkama, M. (2018). Transmit power optimization and feasibility analysis of self-backhauling full-duplex radio access systems. *IEEE Trans. Wireless Commun.* 17, 4219–4236. doi: 10.1109/TWC.2018.2821682
- Korpi, D., Riihonen, T., and Valkama, M. (2016). “Self-backhauling full-duplex access node with massive antenna arrays: power allocation and achievable sum-rate,” in *Proceeding of 24th European Signal Processing Conference (EUSIPCO)* (Budapest: IEEE).
- Kulkarni, M. N., Andrews, J. G., and Ghosh, A. (2017). Performance of dynamic and static TDD in self-backhauled millimeter wave cellular networks. *IEEE Trans. Wireless Commun.* 16, 6460–6478. doi: 10.1109/TWC.2017.2723887
- Kwon, G., and Park, H. (2019). Joint user association and beamforming design for millimeter wave UDN with wireless backhaul. *IEEE J. Sel. Areas Commun.* 37, 2653–2668. doi: 10.1109/JSAAC.2019.2947926
- Lagunas, E., Lei, L., Maleki, S., Chatzinotas, S., and Ottersten, B. (2017a). “Power allocation for in-band full-duplex self-backhauling,” in *Proceeding of 40th International Conference on Telecommunications and Signal Processing (TSP)* (Barcelona: IEEE).
- Lagunas, E., Maleki, S., Lei, L., Tsinos, C., Chatzinotas, S., and Ottersten, B. (2017b). “Carrier allocation for hybrid satellite-terrestrial backhaul networks,” in *Proceeding of IEEE International Conference on Communications Workshops (ICC Workshops)* (Paris).
- Lai, J. Y., Wu, W.-H., and Su, Y. T. (2020). Resource allocation and node placement in multi-hop heterogeneous integrated-access-and-backhaul networks. *IEEE Access* 8, 122937–122958. doi: 10.1109/ACCESS.2020.3007501
- Lashgari, M., Maham, B., and Saad, W. (2017). “Transmission rate maximization in self-backhauled wireless small cell networks,” in *Proceeding of IEEE 86th Vehicular Technology Conference (VTC-Fall)* (Toronto, ON).
- Lei, L., Lagunas, E., Chatzinotas, S., and Ottersten, B. (2018). NOMA aided interference management for full-duplex self-backhauling HetNets. *IEEE Commun. Lett.* 22, 1696–1699. doi: 10.1109/LCOMM.2018.2847672
- Lei, W., Ye, Y., and Xiao, M. (2020). Deep reinforcement learning-based spectrum allocation in integrated access and backhaul networks. *IEEE Trans. Cogn. Commun. Netw.* 6, 970–979. doi: 10.1109/TCCN.2020.2992628
- Li, B., Zhu, D., and Liang, P. (2015). Small cell in-band wireless backhaul in massive MIMO systems: a cooperation of next-generation techniques. *IEEE Trans. Wireless Commun.* 14, 7057–7069. doi: 10.1109/TWC.2015.2464299
- Li, Y., Pappas, N., Angelakis, V., Pioro, M., and Yuan, D. (2015). Optimization of free space optical wireless network for cellular backhauling. *IEEE J. Sel. Areas Commun.* 33, 1841–1854. doi: 10.1109/JSAAC.2015.2432518
- Liang, C., and Yu, F. R. (2014). Wireless network virtualization: a survey, some research issues and challenges. *IEEE Commun. Surv. Tuts* 17, 358–380. doi: 10.1109/COMST.2014.2352118
- Lin, X., Grovlen, A., Werner, K., Li, J., Baldemair, R., Cheng, J.-F. T., et al. (2019). 5G new radio: unveiling the essentials of the next generation wireless access technology. *IEEE Commun. Stand. Mag.* 3, 30–37. doi: 10.1109/MCOMSTD.001.1800036
- Liu, Q., Tian, H., Nie, G., and Wu, H. (2018). “Joint uplink and downlink scheduling in HetNets with wireless self-backhaul,” in *Proceeding of 24th Asia-Pacific Conference on Communications (APCC)* (Ningbo: IEEE).
- Liu, Y., Fang, X., and Xiao, M. (2018). Discrete power control and transmission duration allocation for self-backhauling dense mmWave cellular networks. *IEEE Trans. Commun.* 66, 432–447. doi: 10.1109/TCOMM.2017.2757017
- Liu, Y., Tang, A., and Wang, X. (2020). Joint incentive and resource allocation design for user provided network under 5G integrated access and backhaul networks. *IEEE Trans. Netw. Sci. Eng.* 7, 673–685. doi: 10.1109/TNSE.2019.2910867
- Lukowa, A., Venkatasubramanian, V., and Marsch, P. (2018). “Dynamic self-backhauling in 5G networks,” in *Proceeding of IEEE 29th Annual International Symposium on Personal, Indoor and Mobile Radio Communications (PIMRC)* (Bologna).
- Luong, N. C., Wang, P., Niyato, D., Liang, Y.-C., Han, Z., and Hou, F. (2019). Applications of economic and pricing models for resource management in 5G wireless networks: a survey. *IEEE Commun. Surv. Tuts* 21, 3298–3339. doi: 10.1109/COMST.2018.2870996
- Madapatha, C., Makki, B., Fang, C., Teyeb, O., Dahlman, E., Alouini, M.-S., et al. (2020). On integrated access and backhaul networks: current status and potentials. *IEEE Open J. Commun. Soc.* 1, 1374–1389. doi: 10.1109/OJCOMS.2020.3022529
- Magli, E., Wang, M., Frossard, P., and Markopoulou, A. (2013). Network coding meets multimedia: a review. *IEEE Trans. Multimedia* 15, 1195–1212. doi: 10.1109/TMM.2013.2241415
- Makki, B., Coldrey, M., and Hashemi, M. (2019). *An Adaptive Multiple Access Scheme in Integrated Access and Backhaul Networks*. US Patent App. 15/767,181. Washington, DC: U.S. Patent and Trademark Office.
- Mao, W., Narasimha, M., Simsek, M., and Nikopour, H. (2020). “Network coding for integrated access and backhaul wireless networks,” in *Proceeding of 29th Wireless and Optical Communications Conference (WOCC)* (Newark, NJ: IEEE).
- Meng, D., Li, X., Pu, W., Yang, X., and Li, D. (2018). “An energy-saving scheme with multi-hop transmission for mmWave backhaul networks,” in *Proceeding of IEEE Vehicular Technology Conference (VTC Spring)* (Porto).
- Murugaveni, S., and Mahalakshmi, K. (2020). Optimal frequency reuse scheme based on cuckoo search algorithm in li-fi fifth-generation bidirectional communication. *IET Commun.* 14, 2554–2563. doi: 10.1049/iet-com.2019.1154
- Nakamura, M., Tran, G. K., and Sakaguchi, K. (2019). “Interference management for millimeter-wave mesh backhaul networks,” in *Proceeding of 16th IEEE Annual Consumer Communications & Networking Conference (CCNC)* (Las Vegas, NV).
- Ni, S., Zhao, J., Yang, H. H., and Gong, Y. (2019). Enhancing downlink transmission in MIMO HetNet with wireless backhaul. *IEEE Trans. Veh. Technol.* 68, 6817–6832. doi: 10.1109/TVT.2019.2918574
- Ortiz, A., Asadi, A., Sim, G. H., Steinmetzer, D., and Hollick, M. (2019). SCAROS: a scalable and robust self-backhauling solution for highly dynamic millimeter-wave networks. *IEEE J. Sel. Areas Commun.* 37, 2685–2698. doi: 10.1109/JSAAC.2019.2947925
- Parkvall, S., Dahlman, E., Furuskar, A., and Frenne, M. (2017). NR: The new 5G radio access technology. *IEEE Commun. Stand. Mag.* 1, 24–30. doi: 10.1109/MCOMSTD.2017.1700042
- Pathak, P. H., and Dutta, R. (2011). A survey of network design problems and joint design approaches in wireless mesh networks. *IEEE Commun. Surv. Tuts* 13, 396–428. doi: 10.1109/SURV.2011.060710.00062
- Perez, A., Fouda, A., and Ibrahim, A. S. (2019). “Ray tracing analysis for UAV-assisted integrated access and backhaul millimeter wave networks,” in *Proceeding of IEEE International Symposium on “A World of Wireless, Mobile and Multimedia Networks” (WoWMoM)* (Washington, DC), 1–5.
- Phungamngern, N., Uthansakul, P., and Uthansakul, M. (2013). “Digital and RF interference cancellation for single-channel full-duplex transceiver using a single antenna,” in *Proceeding of IEEE International Conference on Electrical Engineering/Electronics, Computer, Telecommunications and Information Technology (ECTICON)* (Krabi).
- Polese, M., Giordani, M., Roy, A., Castor, D., and Zorzi, M. (2018). “Distributed path selection strategies for integrated access and backhaul at mmwaves,” in *Proceeding of IEEE Global Communications Conference (GLOBECOM)* (Abu Dhabi), 1–7.
- Polese, M., Giordani, M., Zugno, T., Roy, A., Goyal, S., Castor, D., et al. (2020). Integrated access and backhaul in 5G mmWave networks: potential and challenges. *IEEE Commun. Mag.* 58, 62–68. doi: 10.1109/MCOM.001.1900346
- Prasad, A., Uusitalo, M. A., and Maeder, A. (2017). “Energy efficient coordinated self-backhauling for ultra-dense 5G networks,” in *Proceeding of IEEE 85th Vehicular Technology Conference (VTC Spring)* (Sydney, NSW).
- Pu, W., Li, X., Yuan, J., and Yang, X. (2019). Resource allocation for millimeter wave self-backhaul network using markov approximation. *IEEE Access* 7, 61283–61295. doi: 10.1109/ACCESS.2019.2915968
- Qiao, J., Cai, L. X., Shen, X., and Mark, J. W. (2012). “STDMA-based scheduling algorithm for concurrent transmissions in directional millimeter wave networks,” in *Proceeding of IEEE International Conference on Communications (ICC)* (Ottawa, ON), 5221–5225.
- Radunovic, B., and Le Boudec, J.-Y. (2007). A unified framework for max-min and min-max fairness with applications. *IEEE ACM Trans. Netw.* 15, 1073–1083. doi: 10.1109/TNET.2007.896231
- Rahmati, A., Sadeghi, A., and Shah-Mansouri, V. (2015). “Price-based resource allocation for full duplex self-backhauled small cell networks,” in *Proceeding of IEEE International Conference on Communications (ICC)* (London).

- Raithatha, M., Chaudhry, A. U., Hafez, R. H., and Chinneck, J. W. (2020). "Locating gateways for maximizing backhaul network capacity of 5G ultra-dense networks," in *Proceeding of Wireless Telecommunications Symposium (WTS)* (Washington, DC: IEEE).
- Rangan, S., Rappaport, T. S., and Erkip, E. (2014). Millimeter-wave cellular wireless networks: potentials and challenges. *Proc. IEEE* 102, 366–385. doi: 10.1109/JPROC.2014.2299397
- Raza, H. (2011). A brief survey of radio access network backhaul evolution: part I. *IEEE Commun. Mag.* 49, 164–171. doi: 10.1109/MCOM.2011.5784002
- Rezaabad, A. L., Beyranvand, H., Salehi, J. A., and Maier, M. (2018). Ultra-dense 5G small cell deployment for fiber and wireless backhaul-aware infrastructures. *IEEE Trans. Veh. Technol.* 67, 12231–12243. doi: 10.1109/TVT.2018.2875114
- Saha, C., Afshang, M., and Dhillon, H. S. (2018). Bandwidth partitioning and downlink analysis in millimeter wave integrated access and backhaul for 5G. *IEEE Trans. Wireless Commun.* 17, 8195–8210. doi: 10.1109/TWC.2018.2874655
- Saha, C., and Dhillon, H. S. (2019). Millimeter wave integrated access and backhaul in 5G: performance analysis and design insights. *IEEE J. Sel. Areas Commun.* 37, 2669–2684. doi: 10.1109/JSAC.2019.2947997
- Shannon, C. E. (2001). A mathematical theory of communication. *ACM SIGMOBILE Mobile Comput. Commun. Rev.* 5, 3–55. doi: 10.1145/584091.584093
- Sharma, A., Ganti, R. K., and Milleth, J. K. (2017). Joint backhaul-access analysis of full duplex self-backhauling heterogeneous networks. *IEEE Trans. Wireless Commun.* 16, 1727–1740. doi: 10.1109/TWC.2017.2653108
- Shi, H., Prasad, R. V., Onur, E., and Niemegeers, I. G. M. M. (2014). Fairness in wireless networks: issues, measures and challenges. *IEEE Commun. Surv. Tuts* 16, 5–24. doi: 10.1109/SURV.2013.050113.00015
- Siddique, U., Tabassum, H., and Hossain, E. (2015). "Adaptive in-band self-backhauling for full-duplex small cells," in *Proc., IEEE International Conference on Communication Workshop (ICCW)* (London).
- Siddique, U., Tabassum, H., and Hossain, E. (2017). Downlink spectrum allocation for in-band and out-band wireless backhauling of full-duplex small cells. *IEEE Trans. Commun.* 65, 3538–3554. doi: 10.1109/TCOMM.2017.2699183
- Singh, S., Kulkarni, M. N., Ghosh, A., and Andrews, J. G. (2015). Tractable model for rate in self-backhauling millimeter wave cellular networks. *IEEE J. Sel. Areas Commun.* 33, 2196–2211. doi: 10.1109/JSAC.2015.2435357
- Sofia, R., and Mendes, P. (2008). User-provided networks: consumer as provider. *IEEE Commun. Mag.* 46, 86–91. doi: 10.1109/MCOM.2008.4689212
- Soldani, D., and Manzalini, A. (2015). Horizon 2020 and beyond: on the 5G operating system for a true digital society. *IEEE Veh. Technol. Mag.* 10, 32–42. doi: 10.1109/MVT.2014.2380581
- Tabassum, H., Sakr, A. H., and Hossain, E. (2015). "Massive MIMO-enabled wireless backhauls for full-duplex small cells," in *Proceeding of IEEE Global Communications Conference (GLOBECOM)* (San Diego, CA).
- Talgat, A., Kishk, M. A., and Alouini, M.-S. (2020). Stochastic geometry-based analysis of LEO satellite communication systems. *IEEE Commun. Lett.* doi: 10.1109/LCOMM.2020.3029808. [Epub ahead of print].
- Tang, L., Yang, X., Wu, X., Cui, T., and Chen, Q. (2018). Queue stability-based virtual resource allocation for virtualized wireless networks with self-backhauls. *IEEE Access* 6, 13604–13616. doi: 10.1109/ACCESS.2018.2797088
- Tassiulas, L., and Ephremides, A. (1992). Stability properties of constrained queueing systems and scheduling policies for maximum throughput in multihop radio networks. *IEEE Trans. Autom. Control* 37, 1936–1948. doi: 10.1109/9.182479
- Tawarmalani, M., and Sahinidis, N. V. (2004). Global optimization of mixed-integer nonlinear programs: a theoretical and computational study. *Math. Program* 99, 563–591. doi: 10.1007/s10107-003-0467-6
- Teyeb, O., Muhammad, A., Mildh, G., Dahlman, E., Barac, F., and Makki, B. (2019). "Integrated access backhauled networks," in *Proceeding of IEEE 90th Vehicular Technology Conference (VTC-Fall)* (Honolulu, HI).
- Thomsen, H., de Carvalho, E., and Popovski, P. (2015). Using wireless network coding to replace a wired with wireless backhaul. *IEEE Wireless Commun. Lett.* 4, 141–144. doi: 10.1109/LWC.2014.2386857
- Tian, T., Dou, Y., Ren, G., Gu, L., Chen, J., Cui, Y., et al. (2019). "Field trial on millimeter wave integrated access and backhaul," in *Proc. IEEE Vehicular Technology Conference (VTC2019-Spring)* (Kuala Lumpur).
- Trichili, A., Cox, M. A., Ooi, B. S., and Alouini, M.-S. (2020). Roadmap to free space optics. *J. Opt. Soc. Am. B* 37, A184–A201. doi: 10.1364/JOSAB.399168
- Ullah, I., Haile, B. B., Mutafungwa, E., and Hamalainen, J. (2016). "Use of beamforming and interference mitigation techniques for relay backhaul enhancement," in *Proceeding of 39th International Conference on Telecommunications and Signal Processing (TSP)* (Vienna: IEEE).
- Union, I. (2015). *IMT Traffic Estimates for the Years 2020 to 2030*. Report ITU, 2370–0.
- Vu, T. K., Bennis, M., Debbah, M., and Latva-Aho, M. (2019). Joint path selection and rate allocation framework for 5G self-backhauled mm-wave networks. *IEEE Trans. Wireless Commun.* 18, 2431–2445. doi: 10.1109/TWC.2019.2904275
- Vu, T. K., Bennis, M., Samarakoon, S., Debbah, M., and Latva-Aho, M. (2017). Joint load balancing and interference mitigation in 5G heterogeneous networks. *IEEE Trans. Wireless Commun.* 16, 6032–6046. doi: 10.1109/TWC.2017.2718504
- Vu, T. X., Chatzinotas, S., Ottersten, B., and Duong, T. Q. (2018). Energy minimization for cache-assisted content delivery networks with wireless backhaul. *IEEE Trans. Wireless Commun.* 7, 332–335. doi: 10.1109/LWC.2017.2776924
- Vu, T. X., Chatzinotas, S., Ottersten, B., and Trinh, A. V. (2020). Full-duplex enabled mobile edge caching: from distributed to cooperative caching. *IEEE Trans. Wireless Commun.* 19, 1141–1153. doi: 10.1109/TWC.2019.2951369
- Wainio, P. and Seppanen, K. (2016). "Self-optimizing last-mile backhaul network for 5G small cells," in *Proceeding of IEEE International Conference on Communications Workshops (ICCW)* (Kuala Lumpur).
- Wang, H., and Li, J. (2019). *Methods and Apparatus for Backhaul and Access Link Scheduling in Integrated Access and Backhaul Network and Synchronized Networks*. US Patent 10,383,136. Washington, DC: U.S. Patent and Trademark Office.
- Wang, L., Wong, K.-K., Lambotharan, S., Nallanathan, A., and Elkashlan, M. (2018). Edge caching in dense heterogeneous cellular networks with massive MIMO-aided self-backhaul. *IEEE Trans. Wireless Commun.* 17, 6360–6372. doi: 10.1109/TWC.2018.2859936
- Willebrand, H. A. and Ghuman, B. S. (2001). Fiber optics without fiber. *IEEE Spectr.* 38, 40–45. doi: 10.1109/6.938713
- Wu, Y., Pickavet, M., and Colle, D. (2020). "Analysis of the impact of misaligned wireless backhaul links on optical attocell networks," in *Proceeding of 22nd International Conference on Transparent Optical Networks (ICTON)* (Bari: IEEE).
- Yaacoub, E. and Alouini, M.-S. (2020). A key 6G challenge and opportunity—connecting the base of the pyramid: a survey on rural connectivity. *Proc. IEEE* 108, 533–582. doi: 10.1109/JPROC.2020.2976703
- Yang, X., Hua, C., Gu, P., and Xu, W. (2020). "Joint power allocation for non-orthogonal multiple access in wireless backhaul networks," in *Proceeding of IEEE International Conference on Fog Computing (ICFC)* (Sydney, NSW).
- Yao, J., Han, T., and Ansari, N. (2019). On mobile edge caching. *IEEE Commun. Surv. Tuts* 21, 2525–2553. doi: 10.1109/COMST.2019.2908280
- Yuan, D., Lin, H.-Y., Widmer, J., and Hollick, M. (2018). "Optimal joint routing and scheduling in millimeter-wave cellular networks," in *Proceeding of IEEE Conference on Computer Communications (INFOCOM)* (Honolulu, HI).
- Zhai, B., Yu, M., Tang, A., and Wang, X. (2020). "Mesh architecture for efficient integrated access and backhaul networking," in *Proceeding of IEEE Wireless Communications and Networking Conference (WCNC)* (Seoul).
- Zhang, B., Devoti, F., and Filippini, I. (2020). "RL-based resource allocation in mmWave 5G IAB networks," in *Proceeding of Mediterranean Communication and Computer Networking Conference (MedComNet)* (Arona: IEEE).
- Zhang, C., Wu, H., Lu, H., and Liu, J. (2020). "Throughput analysis in cache-enabled millimeter wave HetNets with access and backhaul integration," in *Proceeding of IEEE Wireless Communications and Networking Conference (WCNC)* (Seoul).
- Zhang, H., Chen, Y., Yang, Z., and Zhang, X. (2018). Flexible coverage for backhaul-limited ultradense heterogeneous networks: throughput analysis and η -optimal biasing. *IEEE Trans. Veh. Technol.* 67, 4161–4172. doi: 10.1109/TVT.2018.2791178
- Zhang, J., Liang, F., Li, B., Yang, Z., Wu, Y., and Zhu, H. (2020). Placement optimization of caching UAV-assisted mobile relay maritime communication. *China Commun.* 17, 209–219. doi: 10.23919/JCC.2020.08.017

- Zhang, L., and Ansari, N. (2019). On the number and 3-D placement of in-band full-duplex enabled drone-mounted base-stations. *IEEE Wireless Commun. Lett.* 8, 221–224. doi: 10.1109/LWC.2018.2867501
- Zhang, S., Xu, X., Sun, M., Tao, X., and Liu, C. (2020). “Joint spectrum and power allocation in 5G integrated access and backhaul networks at mmWave band,” in *Proceeding of IEEE 31st Annual International Symposium on Personal, Indoor and Mobile Radio Communications* (London).
- Zhang, T., Biswas, S., and Ratnarajah, T. (2019). “An analysis on caching in full-duplex enabled mmWave IAB HetNets,” in *Proceeding of IEEE International Symposium on Wireless Communication Systems (ISWCS)* (Oulu).
- Zhang, X., Liu, F., and Xia, H. (2019). “Ergodic capacity analysis for full-duplex integrated access and backhaul system,” in *Proceeding of IEEE Global Conference on Signal and Information Processing (GlobalSIP)* (Ottawa, ON).
- Zhang, Y., Ramamurthi, V., Huang, Z., and Ghosal, D. (2020). “Co-optimizing performance and fairness using weighted pf scheduling and IAB-aware flow control,” in *Proceeding of IEEE Wireless Communications and Networking Conference (WCNC)* (Seoul), 1–6.
- Zhu, Y., Niu, Y., Li, J., Wu, D. O., Li, Y., and Jin, D. (2016). QoS-aware scheduling for small cell millimeter wave mesh backhaul. in *Proceeding of IEEE International Conference on Communications (ICC)* (Kuala Lumpur), 1–6.

Conflict of Interest: The authors declare that the research was conducted in the absence of any commercial or financial relationships that could be construed as a potential conflict of interest.

Copyright © 2021 Zhang, Kishk and Alouini. This is an open-access article distributed under the terms of the Creative Commons Attribution License (CC BY). The use, distribution or reproduction in other forums is permitted, provided the original author(s) and the copyright owner(s) are credited and that the original publication in this journal is cited, in accordance with accepted academic practice. No use, distribution or reproduction is permitted which does not comply with these terms.